

PB50 | PB51

Mobile Printer



User Guide

Intermec Technologies Corporation

Worldwide Headquarters

6001 36th Ave.W.

Everett, WA 98203

U.S.A.

www.intermec.com

The information contained herein is provided solely for the purpose of allowing customers to operate and service Intermec-manufactured equipment and is not to be released, reproduced, or used for any other purpose without written permission of Intermec Technologies Corporation.

Information and specifications contained in this document are subject to change without prior notice and do not represent a commitment on the part of Intermec Technologies Corporation.

© 2007-2012 by Intermec Technologies Corporation. All rights reserved.

The word Intermec, the Intermec logo, Norand, ArciTech, Beverage Routebook, CrossBar, dcBrowser, Duratherm, EasyADC, EasyCoder, EasySet, Fingerprint, i-gistics, INCA (under license), Intellitag, Intellitag Gen2, JANUS, LabelShop, MobileLAN, Picolink, Ready-to-Work, RoutePower, Sabre, ScanPlus, ShopScan, Smart Mobile Computing, SmartSystems, TE 2000, Trakker Antares, and Vista Powered are either trademarks or registered trademarks of Intermec Technologies Corporation.

There are U.S. and foreign patents as well as U.S. and foreign patents pending.

Wi-Fi is a registered certification mark of the Wi-Fi Alliance.

Bluetooth is a trademark of Bluetooth SIG, Inc., U.S.A.

Document Change Record

This page records changes to this document. The document was originally released as Revision 001.

Version Number	Date	Description of Change
008	5/2012	<ul style="list-style-type: none">Updated the manual to include information on how to load fanfold media.
007	4/2012	These changes were made for the 11.5.0 firmware release: <ul style="list-style-type: none">Updated the “Understanding the Printer Language” section to “Selecting the Printer Language.”Updated “Upgrading the Firmware” information.
006	9/2011	<ul style="list-style-type: none">Removed information on floodcoated media.Added procedure for configuring wireless network with PrintSet.
005	4/2011	<ul style="list-style-type: none">Added an index.Updated black mark sensor information.
004	1/2010	<ul style="list-style-type: none">Updated procedures for upgrading printer firmware and cleaning the printer.
003	5/2009	<ul style="list-style-type: none">Added information describing the PB51 printer.Added changes to the media adjust in the PB50 printer.
002	11/2008	These changes were made for the current release: <ul style="list-style-type: none">Support for the ESC/P programming language.Added the radioless PB50 printer.Change to the Ready-to-Work indicator behavior.Added linerless media support.New icons for Bluetooth radio and addition of printhead lifted error message.Added of power management options Sleep Timer and Standby Timer.

Contents

Before You Begin.....	ix
Safety Information.....	ix
Global Services and Support.....	ix
Warranty Information.....	ix
Web Support.....	ix
Send Feedback.....	x
Telephone Support.....	x
Who Should Read This Manual.....	x
Related Documents.....	x

1 Using the Mobile Printer..... 1

Introducing the Mobile Printer.....	2
What's New?.....	2
Features of the Printer.....	2
Identifying the Parts of the Printer.....	3
Understanding the Control Panel.....	3
Selecting the Printer Language.....	6
Understanding the Printer Sounds.....	9
Using the Batteries.....	9
Installing the Battery.....	10
Charging the Batteries.....	11
Understanding the Battery Icon.....	11
Managing Power on the Mobile Printer.....	12
Understanding the Sleep Timer.....	12
Understanding the Standby Timer.....	12
Extending Battery Life.....	13
Loading Media.....	14
Understanding the Printer Modes.....	21
Understanding Ready Mode.....	21
Understanding Information Mode.....	21
Understanding Pause Mode.....	22
Understanding Setup Mode.....	23
Understanding Error Mode.....	24
Understanding Dump Mode.....	24
Understanding Extended Test Mode.....	25
Printing a Test Page.....	26

2	Configuring the Mobile Printer	29
	Connecting the Printer to Your PC	30
	Connecting the Printer Through the USB Interface	30
	Connecting the Printer Through the Serial Port	31
	Connecting the Printer to Your Network	32
	Setting Up Bluetooth Communications	32
	Setting Up 802.11 Radio Communications	34
	Configuring Wireless Printing Using IPL	37
	Configuring Wireless Printing Using Fingerprint	40
	Configuring the Printer Settings	42
	Changing Configuration Settings from the Control Panel	42
	Changing Configuration Settings From PrintSet	44
	Changing Configuration Settings Using the Command Line	44
	Changing Configuration Settings From the Printer Home Page	45
	Changing Configuration Settings From the SmartSystems Console ..	46
	Upgrading the Firmware	47
	Upgrading the Printer Firmware Using PrintSet	47
	Upgrading the Printer Firmware Using the Printer Home Page	49
	Upgrading Printer Firmware Using SmartSystems Foundation	51
	Upgrading the Printer Firmware Using a Communications Program	51
	Downloading Fonts and Graphics	55
3	Troubleshooting and Maintaining the Mobile Printer	57
	Troubleshooting the Mobile Printer	58
	Contacting Product Support	58
	Understanding Error Messages	58
	Troubleshooting Printer Problems and Finding Solutions	60
	Troubleshooting Communication Problems	62
	Using the Line Analyzer in Fingerprint	62
	Using Dump Mode in IPL	63
	Restarting the Mobile Printer	64
	Cleaning the Printer	65
	Cleaning the Printhead	66
	Cleaning the Platen Roller	67
	Cleaning the Printer Exterior	67

Cleaning the Printer Media Compartment 68

A Specifications 69

Specifications.....70

Interfaces.....74

 RS-232 Serial Interface74

 USB Interface.....75

Accessories for the Mobile Printer76

B IPL and Fingerprint Setup Menus..... 79

IPL Setup Menu80

Fingerprint Setup Menu.....81

I Index 83

Contents

Before You Begin

This section provides you with safety information, technical support information, and sources for additional product information.

Safety Information

Your safety is extremely important. Read and follow all warnings and cautions in this document before handling and operating Intermec equipment. You can be seriously injured, and equipment and data can be damaged if you do not follow the safety warnings and cautions.

This section explains how to identify and understand warnings, cautions, and notes that are in this document.



A warning alerts you of an operating procedure, practice, condition, or statement that must be strictly observed to avoid death or serious injury to the persons working on the equipment.



A caution alerts you to an operating procedure, practice, condition, or statement that must be strictly observed to prevent equipment damage or destruction, or corruption or loss of data.



Note: Notes either provide extra information about a topic or contain special instructions for handling a particular condition or set of circumstances.

Global Services and Support

Warranty Information

To understand the warranty for your Intermec product, visit the Intermec website at www.intermec.com and click **Support > Returns and Repairs > Warranty**.

Web Support

Visit the Intermec website at www.intermec.com to download our current manuals (in PDF). To order printed versions of the Intermec manuals, contact your local Intermec representative or distributor.

Before You Begin

Visit the Intermec technical knowledge base (Knowledge Central) at www.intermec.com and click **Support** > **Knowledge Central** to review technical information or to request technical support for your Intermec product.

Send Feedback

Your feedback is crucial to the continual improvement of our documentation. To provide feedback about this manual, please contact the Intermec Technical Communications department directly at TechnicalCommunications@intermec.com.

Telephone Support

In the U.S.A. and Canada, call **1-800-755-5505**.

Outside the U.S.A. and Canada, contact your local Intermec representative. To search for your local representative, from the Intermec website, click **About Us** > **Contact Us**.

Who Should Read This Manual

This document is for the person who is responsible for installing, configuring, and maintaining the PB50 or PB51 mobile printer.

This document provides you with information about the features of the mobile printer, and how to install, configure, operate, maintain, and troubleshoot it.

Before you work with the mobile printer, you should be familiar with your network and general networking terms, such as IP address.

Related Documents

This is a list of related Intermec documents:

- *Intermec Fingerprint Command Reference Manual*
- *Intermec Fingerprint Developer's Guide*
- *Intermec Printer Language (IPL) Command Reference Manual*
- *ESC/P Programmer's Reference Manual*
- *ZSim Programmer's Guide*
- *CSim Programmer's Guide*
- *DSim Programmer's Guide*

The Intermec website at www.intermec.com contains our documents (as PDF files) that you can download for free.

To download documents

- 1** Visit the Intermec website at www.intermec.com.
- 2** Click the **Products** tab.
- 3** Use the **Products** menu, navigate to your product page. For example, to find the PB50 mobile printer page, click **Printers and Media > Mobile Printers > PB50**.
- 4** Click the **Manuals** tab.

Before You Begin

1

Using the Mobile Printer

Use this chapter to familiarize yourself with your mobile printer. This chapter contains these sections:

- **Introducing the Mobile Printer**
- **Features of the Printer**
- **Using the Batteries**
- **Loading Media**
- **Understanding the Printer Modes**
- **Printing a Test Page**

Introducing the Mobile Printer

The PB50, PB50C, and PB51 are rugged direct thermal label and receipt printers designed for use with Intermec mobile computers and SF51 and SR61 scanners. Use the PB50 for label printing, and the PB51 for receipt printing.



Note: Unless otherwise noted, this manual uses the term “printer” to refer to both the PB50 and PB51 printers.

The printer provides:

- print resolution of 203 dpi.
- print speeds of up to 100 mm per second (4 ips).
- 802.11 radio, Bluetooth radio, or no radio options.

What’s New?

This version of the printer manual contains these changes:

- Updated the user guide to include information on how to load fanfold media. For more information, see **“Loading Media” on page 14.**

Features of the Printer

This section explains how to use the printer and contains information about the:

- parts of the printer.
- Control Panel.
- printer languages.
- printer sounds.

Identifying the Parts of the Printer

Use the illustration to understand some of the features of the printer.

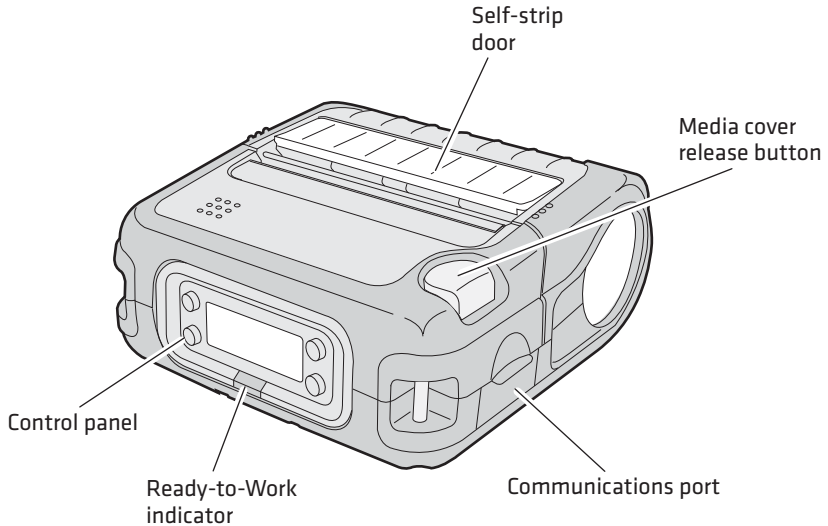

PB50 and PB51 Mobile Printer: This illustration shows the important features of the printer. A weather-resistant flap protects the communications port and the external power connector.



Note: Only the PB50 has a self-strip door.

Understanding the Control Panel

The printer control panel contains four buttons, a liquid crystal display (LCD), and one LED indicator. Use the four buttons to navigate the menu system and perform functions on the printer. Use the following tables to understand the buttons, menu system, and status LED.

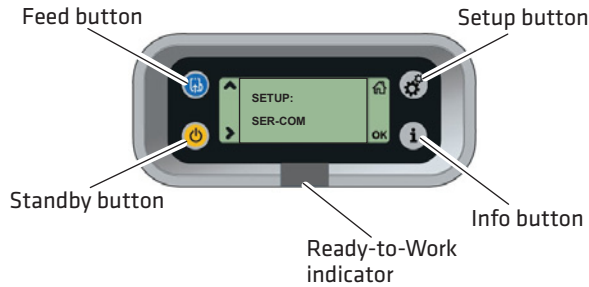











Printer Control Panel: Use this illustration to familiarize yourself with the buttons and lights on the printer.

Understanding How to Use the Printer Buttons

Button Name	Button	Function
Feed		<p>Press to advance label or receipt paper without printing. The amount of media advanced depends on the type of media loaded in the printer. The printer will advance 5 mm (0.2 inch), an entire label, or a configured length of media based on your media and settings.</p> <p>If you press and hold the button for longer than two seconds while in Ready mode, the printer performs a testfeed to calibrate the media (Fingerprint or ESC/P).</p> <p>If the printer is printing, press this button to start and stop Pause mode.</p>
Setup		<p>Press to start and stop Setup mode (IPL and Fingerprint only).</p> <p>Press and hold to cancel printing (ESC/P only).</p>
Standby (Power)		<p>Press to start Standby mode. In Standby mode, the radio, display, and backlight are turned off.</p> <p>Press to turn the printer on and start Ready mode.</p>
Info		<p>Press to show a summary of network connection settings and error conditions (Fingerprint and IPL only). Each information message appears on the screen for five seconds.</p> <p>Press in Pause mode to cancel the print job (Fingerprint and IPL only).</p> <p>The button does not have a unique function when using the ESC/P language.</p>

The buttons can act as “soft keys,” which means that the function of each button depends on the state of the printer. A small icon appears in the screen next to the button to indicate the function it performs.

Understanding the Soft Keys

Button	Soft Keys	Description
		Moves through the settings at the same level in the menu system.
		Stops Setup mode and returns to Ready mode.
		<ul style="list-style-type: none"> Moves up one level in the menu system. This soft key appears in Setup mode.
		<ul style="list-style-type: none"> Increases the value of a number when editing settings, such as an IP address. This soft key appears in Setup mode.
		<ul style="list-style-type: none"> Pauses the printing job. This icon appears only when you are printing.
	OK	<ul style="list-style-type: none"> Moves down one level in the menu system and saves changes to a setting.
		<ul style="list-style-type: none"> Cancels the print job (Fingerprint or IPL), or stops Information mode.

The only LED on the printer is the blue Ready-to-Work™ indicator.

Understanding the Ready-to-Work Indicator

Indicator State	Description
Off	When the light is off, it means one of the following: <ul style="list-style-type: none"> The printer is in Standby mode. The printer is in Info mode. The printer is in Setup mode.
On	The printer is powered on and operating.

Understanding the Ready-to-Work Indicator (continued)

Indicator State	Description
Blinking	When the light is blinking, it means one of the following: <ul style="list-style-type: none">• The printer is out of paper.• The media cover is open.• There is a printer error that requires you to perform an action. For a list of possible problems, see “Troubleshooting the Mobile Printer” on page 58.

Selecting the Printer Language

The language you choose affects the functionality of the printer and how you use it. This manual contains information for using each printer language.

If your printer has firmware version 11.4.0 or earlier, your printer comes with one of the following printer languages:

- Fingerprint
- Intermec Printer Language (IPL)
- ESC/P



Note: If your printer has version 11.4.0 or earlier and you want to run a simulator language, you can download ZSim, CSim, and DSIm from the Intermec website at www.intermec.com.

If you upgrade your printer firmware to version 11.5.0 or later, your printer is loaded with all of the following printer languages:

- Fingerprint
- Intermec Printer Language (IPL)
- ESC/P
- ZSim
- CSim
- DSIm

The first time you start your printer after you upgrade your firmware, you are prompted to select a printer language. The language you select automatically runs each time you turn on your printer.

Printer Language Descriptions

Printer Language	Description
Intermec Printer Language (IPL)	IPL is an easy-to-use programming language that lets you design, download, and modify formats. To setup, configure, and use IPL, see the <i>Intermec Printer Language (IPL) Command Reference Manual</i> .
Fingerprint	Intermec Fingerprint is a BASIC-inspired, printer-resident programming language you use to design label formats and write custom printer application software. To setup, configure, and use Fingerprint, see the <i>Intermec Fingerprint Command Reference Manual</i> or the <i>Intermec Fingerprint Developer's Guide</i> .
ESC/P	ESC/P is Epson™ interpreter program that interprets the Epson Standard Code for Printers command language. To setup, configure, and use ESC/P, see the <i>ESC/P Programmer's Reference Manual</i> .
ZSim	ZSim is a Zebra™ interpreter program that interprets ZPL II or later programs. To setup, configure, and use ZSim, see the <i>ZSim Programmer's Guide</i> .
CSim	CSim is Zebra™ interpreter program that interprets CPCL command language. To setup, configure, and use ZSim, see the <i>CSim Programmer's Guide</i> .
DSim	DSim is a Datamax™ simulation program that runs Datamax programs. To setup, configure, and use DSim, see the <i>DSim Programmer's Guide</i> .

The current printer language and firmware version appear on the screen when the printer is in Ready mode.



The Screen of a Printer Running IPL Firmware

To select your printer language

- 1 Turn on your printer.

- 2 If the printer language you want to run appears, press the key that corresponds to the printer language.

If the printer language you want to run does not appear, press the key that corresponds to the next button.

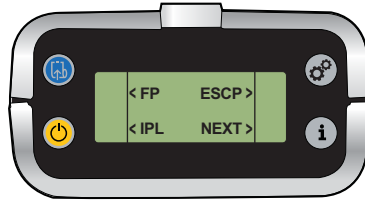

- 3 Press the key that corresponds to the printer language you want to run on your printer.

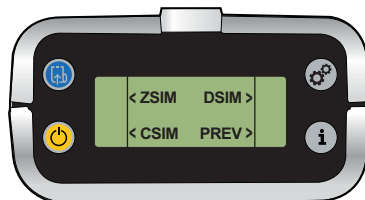

- 4 Restart your printer.

Once your printer is running a particular printer language, you can change the printer language from the Setup menu. The way that you access the command language menu depends on which language you are currently running.

Changing the Printer Language From the Setup Menu

Language	How to Access the Command Language Menu
IPL	<ul style="list-style-type: none"> Go to SETUP > TEST/SERVICE > CMD LANGUAGE.
Fingerprint or Direct Protocol	<ul style="list-style-type: none"> Go to SETUP > PRINT DEFS > CMD LANGUAGE.
ZSim, DSIm, or CSIm	<ol style="list-style-type: none"> 1 Press Setup button. 2 Enter the Fingerprint password: 8311. 3 Press Setup button. 4 Go to SETUP > PRINT DEFS > CMD LANGUAGE.



Note: You cannot configure ESC/P from the Setup menu. If your printer is originally in ESC/P and you want to change to Fingerprint or IPL, you need to enter Extended Test Mode and select the printer language. For more information, see **“Understanding Extended Test Mode” on page 25**.

Understanding the Printer Sounds

The printer plays sounds in response to several actions that you can perform. Use the following table to understand when the sounds occur and what they mean.

Understanding the Printer Sounds

Sound	Occurs When:
Power	<ul style="list-style-type: none"> You connect the AC power cable or insert a battery. The printer starts charging the battery.
Hardware	You open the media door, close the media door, or insert a cable.
Button	You press any of the printer buttons.
Error	<ul style="list-style-type: none"> The printer cannot feed paper or print a job because of a hardware issue such as the media door open, a paper jam, or there is no media. An error occurs such as a paper jam or a print error.

Using the Batteries

The printer uses a rechargeable 2200 mAh lithium-ion battery (Model AB13) for power. You must fully charge the battery before you can use the printer. When in Standby mode, a fully charged battery can last up to one week without recharging.



Caution

Use Intermec Model AB13 battery only. Use of another battery may present a risk of fire or explosion.



Caution

The Model AB13 battery may present a fire or chemical burn hazard if mistreated. Do not disassemble, heat above 100 °C (212 °F), or incinerate.

Dispose of used batteries promptly. Keep away from children.

Installing the Battery

Make sure you fully charge the battery before you use your printer. You can charge the battery when it is installed in the printer, or using the AC18 4-bay battery charger.

To install the battery

- 1** Lay the printer upside-down on a flat surface.
- 2** Insert the battery with the tab facing away from the front control panel.

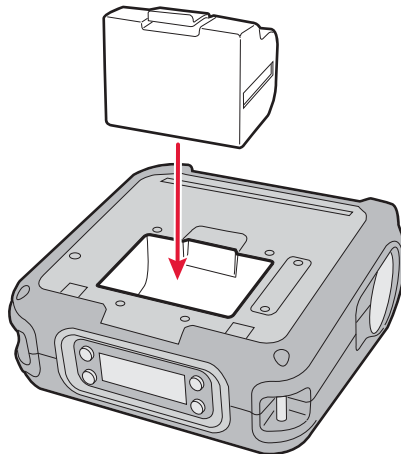

- 3** Insert the edge of the battery under the lip of the printer and then push down until you hear the battery latch click.

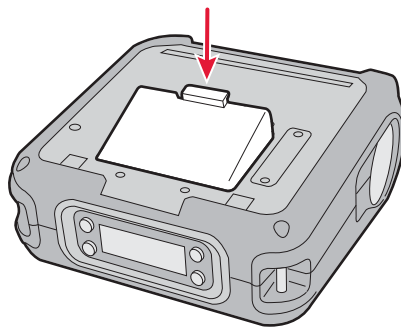

Charging the Batteries

There are two ways to charge the battery:

- Connect AC power to the printer and charge the battery while it is in the printer.
- Charge the battery in the AC18 4-bay battery charger. For more information, see [AC18 4-Bay Battery Charger Instructions](#).

It takes approximately six hours to charge the battery while it is installed in the printer. To charge the battery inside the printer, you need:

- an Intermec 12 VDC power supply (Model AE19).
- an AC power cord.





To charge the battery inside the printer

- 1 Install the battery in the printer. For help, see the previous section, [“Installing the Battery” on page 10](#).
- 2 Connect the power supply to the DC power connector on the printer.
- 3 Connect one end of the power cord to the power supply, and then plug the other end into an AC outlet.

Understanding the Battery Icon

The easiest way to tell the status of your battery is to look at the battery icon on the control panel of the printer.

Battery Icon Status

Icon	Status
	Battery is fully charged.
	Battery has a medium charge. You should be able to work for several more hours before charging or replacing the battery.
	Battery is low. You need to replace the battery soon.
	Battery is critically low. You need to replace the battery now.
	Battery charging error. You may need to replace the battery.

Battery Icon Status (continued)

Icon	Status
	External power connected and there is no battery in the printer.

Managing Power on the Mobile Printer

Use the power options on the printer to manage and conserve battery power. From the Power option in Setup mode, you can set Low Battery, Sleep Timer, and Standby Timer.

Use the Low Battery option to set the battery voltage at which the low battery warning appears. The values for Low Battery range from 12.1 V to 16.8 V in 0.1 V increments. The default setting is 13.5 V.

Understanding the Sleep Timer

Use the Sleep Timer option to set the amount of time it takes for the printer to go to “sleep” if it is not printing and you do not have any interaction with it. When the printer goes to “sleep,” it turns off the backlight and dims the Ready-to-Work indicator. By default, the printer backlight turns off after 20 seconds of no user interaction. You can set Sleep Timer to always off, always on, 5 seconds, 10 seconds, 20 seconds, 30 seconds, or 60 seconds. The backlight turns on when:

- the printer begins printing.
- you press a button.
- you connect the printer to external power.
- you are communicating with or sending data to the printer.



Note: If you have the Sleep Timer set to always on, the Standby timer setting have no effect.

Understanding the Standby Timer

Use the Standby Timer option to turn off power to the radio, the display, and the backlight. The Standby Timer option has the same effect on the printer as pressing the Standby button.

When the printer is in Standby mode, both the LCD and the Ready-to-Work indicator turn off. You can set Standby Timer to 5 mins, 10 mins, 20 mins, 30 mins, 60 mins, or disabled. Press the **Standby** button to turn the printer back on.

Extending Battery Life

Here are some tips for extending the overall life of your battery:

- Never expose the battery to direct sunlight or temperatures over 50 °C (122 °F).
- Only charge the battery inside the printer using a power supply, or in the 4-bay battery charger (Model AC18).
- Do not set the backlight to **always on**. This setting disables the automatic power saving modes.

Here are some tips for extending the life of your battery between charges:

- When you are not using the printer, press the **Standby** button to start Standby mode. Press and hold the **Standby** button for about one second to stop Standby mode and start Ready mode.
- Remove the battery from the printer if you will not be using it for three days or more.
- Do not operate the printer in extremely cold temperatures. Using the printer in temperatures below 0 °C (32 °F) reduces the overall battery life.

Over time, rechargeable batteries lose the ability to maintain a charge. You can only recharge a battery a finite number of times before you must replace it.

Loading Media

You can use roll or fanfold receipt media with both the PB50 and PB51 printers. Your printer ships with a small amount of media loaded, and a test page printed to make sure that the printer works.

The PB50 printer supports self-strip printing applications. For information on how to correctly load self-strip media, see **“To load media for self-strip printing (PB50 only)” on page 19**. For information on media specifications, see **“Specifications” on page 70**.

To load roll media

- 1 Make sure the printer is in Ready mode.
 - If the printer is off or in Standby mode, press the **Standby** button.
 - If the printer is on, press the  soft key (usually the **Setup** button) to return to Ready mode.
- 2 Press the blue media cover release button until the cover releases.

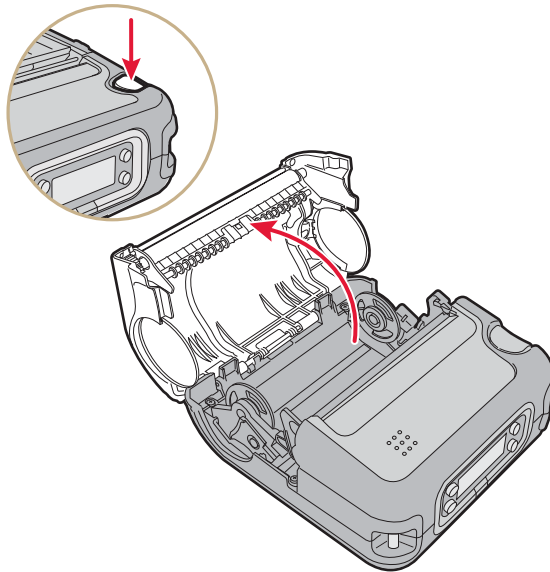

- 3** Slide the two media supports apart.
- 4** Insert the roll of media and press the media adjust guide until the roll is held firmly in place. Make sure you load the media clockwise so that it pulls off the core from the bottom of the printer.

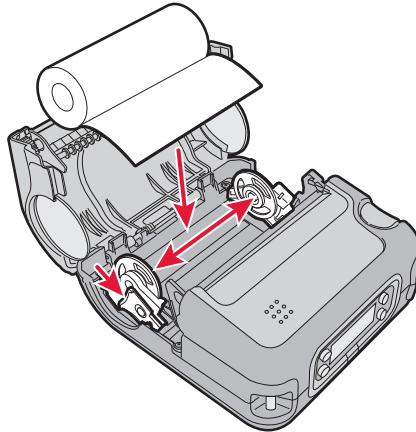

- 5** Pull out approximately 8 cm (3 inches) of the media.
- 6** Close the media cover. The printer emits the hardware sound to tell you that the media door closed correctly.

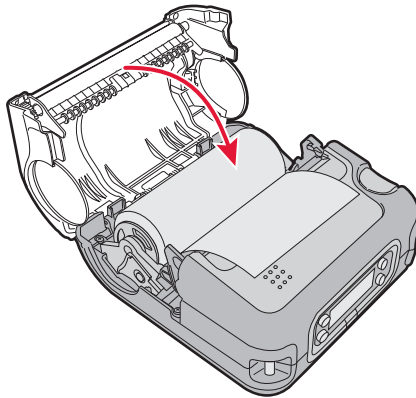

- 7 Press down on the self-strip door to make sure the media cover is completely latched.



Note: The PB51 does not have a self-strip door. Instead, the self-strip door is molded plastic and part of the media cover.

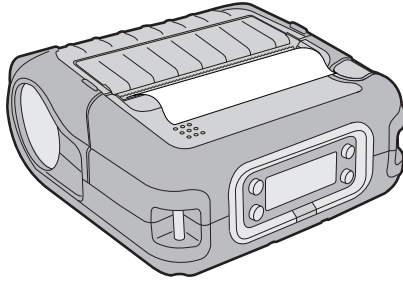

- 8 Press and hold the **Feed** button for more than two seconds to calibrate the media.

To load fanfold media

- 1** Make sure the printer is in Ready mode.
 - If the printer is off or in Standby mode, press the **Standby** button.
 - If the printer is on, press the  soft key (usually the **Setup** button) to return to Ready mode.
- 2** Press the blue media cover release button until the cover releases.

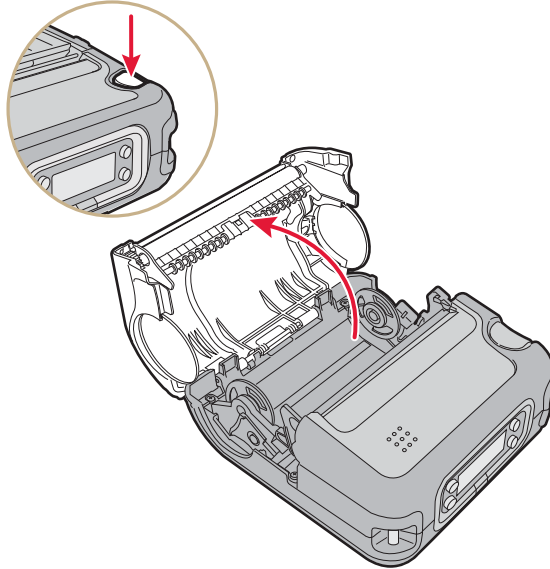

- 3** Slide the two media supports apart.

Chapter 1 – Using the Mobile Printer

- 4 Insert a dummy core and press the media adjust guide until the dummy core is held firmly in place.

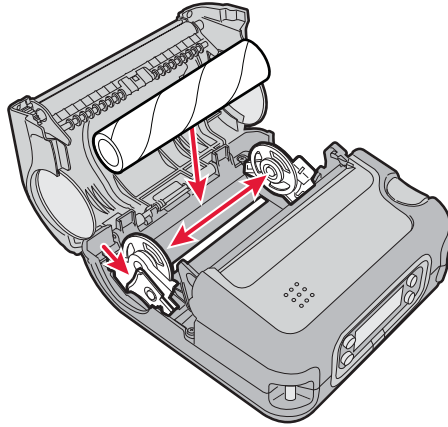

- 5 Load the fanfold media from the bottom of the printer.

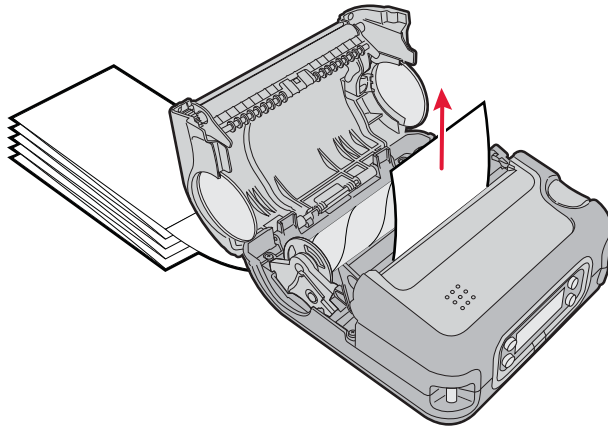

- 6 Pull out approximately 8 cm (3 inches) of the media.

- 7 Close the media cover. The printer emits the hardware sound to tell you that the media door closed correctly.

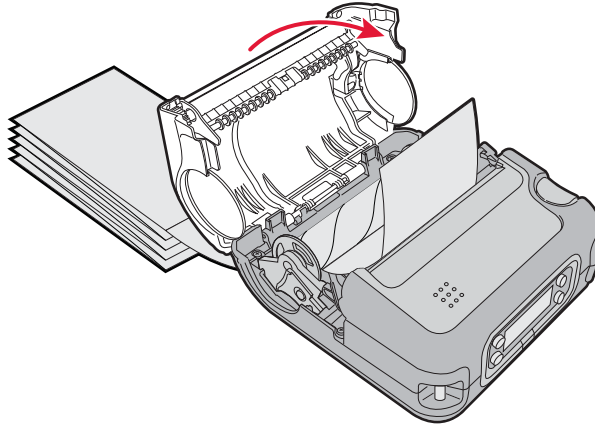

To load media for self-strip printing (PB50 only)

- 1 Complete Steps 1 through 5 in the previous procedure.
- 2 Open the self-strip door in the media cover.

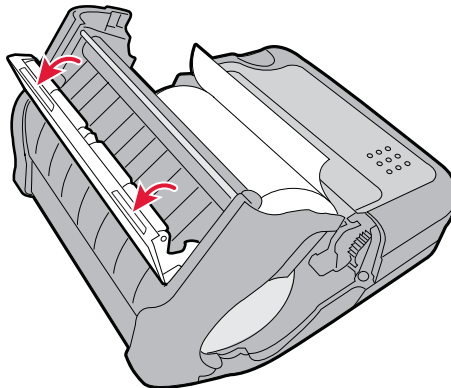

- 3 Remove a label from the roll of media so that you have several inches of label liner.

- 4 Feed the label liner over the self-strip bar and out the back of the self-strip door.

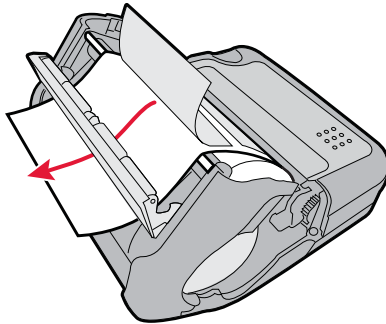

- 5 Close the media cover until it latches and press down on the self-strip door to make sure it locks.

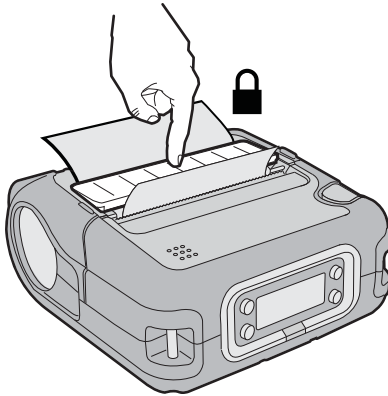

- 6 Pull on the liner to tighten it.
- 7 Press and hold the **Feed** button for more than two seconds to calibrate the media.

Understanding the Printer Modes

The printer has seven modes: Ready, Information, Pause, Setup, Error, Dump, and Extended Test. The following sections explain each mode.

Understanding Ready Mode

The printer is in Ready mode when the printer is on and ready to print. The main screen shows the power status, the radio status, printer language, and firmware version number.

To start Ready mode

- If the printer is off or in Standby mode, press the **Standby** button.
- If the printer is on, press the  soft key.



The Printer in Ready Mode

Understanding Information Mode

When the printer is in Information mode, it shows a subset of network information about the printer. If there is an error, the error message appears first, followed by the printer information. Each message appears for five seconds.



Note: You must use IPL or Fingerprint to start Information mode.

The printer stops Information mode and returns to Ready mode automatically. You can also press the **Information** button again (or the **X** soft key) to stop Information mode manually.

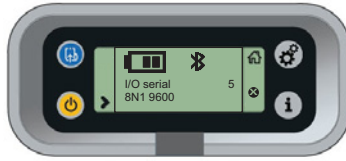

The Printer in Information Mode

To start or stop Information mode

- Press the **Information** button on the control panel.

Understanding Pause Mode

Use Pause mode to temporarily suspend printing, or to cancel the current print job. Once you pause the printer, the Pause mode screen appears.



The Printer in Pause Mode

To start Pause mode

- Press the **Feed** button while the printer is printing.

To stop Pause mode and resume printing

- Press the **Feed** button (or **||** soft key).

To cancel the current print job with Fingerprint or IPL

- 1 Press the **Feed** button to pause printing.
- 2 Press the **Information** button (or **X** soft key) to cancel the current print job.

To cancel the current print job with ESC/P

- Press and hold the **Setup** button.

Understanding Setup Mode

Use Setup mode to change settings on the printer.



Note: You must use IPL or Fingerprint to start Setup mode. For more information on how to change printer settings, see [“Configuring the Printer Settings” on page 42](#).



Sample Setup Mode Screen

To start or stop Setup mode

- Press the **Setup** button.

Some settings use normal editing mode, and other settings use enhanced editing mode. You must press the **OK** soft key to confirm your changes before the setting is saved.

Editing Settings in Setup Mode

Editing Mode	To Navigate	To Confirm
Normal	<ul style="list-style-type: none"> • Press ➤ to move to the next choice. • Press ⬆ to select the previous menu. 	Press OK .
Enhanced	<ul style="list-style-type: none"> • Press ➤ to move the cursor. When the cursor blinks, you can change the setting. • Press + to increase the value of the currently selected setting. 	Press OK .

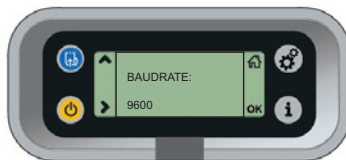

Normal Editing Mode: In normal editing mode, you see an up arrow and a right arrow for making selections.



Enhanced Editing Mode: In enhanced editing mode, you see a plus sign (+) and a right arrow to change the value of numeric settings.

Understanding Error Mode

The printer starts Error mode when it detects an error condition, such as a low battery or a paper jam. Some error messages appear on the screen immediately when they occur, such as DOOR OPEN. Other error messages do not appear until you press the **Info** button. If there is more than one error, the errors appear in the order that they occurred.



Sample Error Mode Screen

If an error message appears, see [“Understanding Error Messages” on page 58](#) for more information on how to fix the problem.

Understanding Dump Mode

Dump mode can be used to identify simple problems, such as label alignment. Extended Test mode requires more user interaction and lets you choose which tests you want the printer to perform.

To start and stop Dump mode

- 1 Make sure the printer is in Ready mode and is loaded with media.
- 2 Press and hold the **Feed** and **Standby** buttons for about five seconds, or until the SELECT MEDIA message appears on the screen.

- 3 Release the buttons. The printer performs a test feed (sensor calibration), prints a series of test labels, and then starts Dump mode.

While in Dump mode, information received by the printer is printed immediately.

- 4 Press **Feed** to stop Dump mode.

After you stop Dump mode, the printer returns to Ready mode. For more information on additional options available in Dump mode with IPL, see “[Troubleshooting Communication Problems](#)” on [page 62](#).

Understanding Extended Test Mode

Use Extended Test mode to run additional diagnostic tests or resolve more difficult problems, including printing specific test labels, starting Dump mode, and resetting the printer to factory default settings.

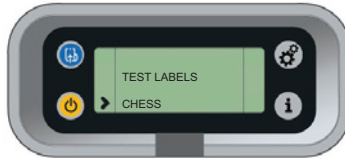

Sample Extended Test Mode Screen

To start Extended Test mode

- 1 Make sure that the printer is loaded with media.
- 2 Press the media cover release button to open the media cover.
- 3 Press the **Standby** button to turn the printer off.
- 4 Press the **Feed** and **Standby** buttons at the same time until CLOSE PRINTER DOOR appears on the screen.
- 5 Close the media cover. You are now in Extended Test mode.
 - Press **➤** to select the next function or option.
 - Press **OK** to start the current function.
 - Press **⏪** to stop Extended Test mode.

Options in Extended Test Mode

Function	Description
Select Media	This option is almost the same as the process in Dump mode, except that the printer performs a slow testfeed in Extended Test mode. The slow testfeed can help resolve gap or mark detection problems.
Test Labels	This option allows you to print test labels one at a time. Press OK to print the next label.
Dump Mode	This option starts Dump mode. For more information on Dump mode, see “Troubleshooting Communication Problems” on page 62 .
Factory Default	This option restores the factory default settings. Press OK to select this option, then follow the instructions on the screen.
Setup and Exit	This option stops Extended Test mode and puts the printer in Setup mode.
Exit	This option stops Extended Test mode.

Printing a Test Page

After you have loaded media in the printer, you are ready to print a test page, or testprint. Each printer language has several different testprint options. If you cannot get the information to print, see **“Troubleshooting the Mobile Printer” on page 58**.

To print a test page with a printer loaded with IPL

- 1 Press the **Setup** button.
- 2 Press **▶** until **Test/Service** appears on the screen.
- 3 Press **OK** to select the Test/Service menu.
- 4 Press **OK** to select the Testprint Config menu.
- 5 Press **OK** to select the Config menu.
- 6 Press **▶** to choose a test page.
- 7 Press **OK** to print the selected test page.

To print a test page with a printer loaded with Fingerprint

- 1** Press the **Setup** button.
- 2** Press **➤** until **Print Defs** appears on the screen.
- 3** Press **OK** to select the Print Defs menu.
- 4** Press **➤** until you reach **Testprint**.
- 5** Press **OK** to select the Testprint menu.
- 6** Press **➤** to choose a test page.
- 7** Press **OK** to print the selected test page.

To print a test page with a printer loaded with ESC/P

- 1** Press and hold the **Feed** and **Power** buttons for approximately five seconds.
- 2** Release the buttons when the printer shows the SELECT MEDIA message, or a message stating the type of media loaded in the printer.
- 3** Press the **Feed** button to stop Dump Mode.

2

Configuring the Mobile Printer

This chapter contains these sections:

- **Connecting the Printer to Your PC**
- **Connecting the Printer to Your Network**
- **Configuring the Printer Settings**
- **Upgrading the Firmware**
- **Downloading Fonts and Graphics**

Connecting the Printer to Your PC

You can easily connect the printer to your PC using one of these ports:

- USB port
- RS-232 serial interface port

Connecting the Printer Through the USB Interface

To connect the printer to your PC through the USB port, you need to install Intermec InterDriver® software. To make sure you have the latest version of InterDriver, go to the Downloads page for the printer at <http://www.intermec.com/support/downloads/index.aspx>.

You also need a separately purchased USB cable (P/N 321-611-xxx).

To connect the printer through the USB port

- 1 Run the InterDriver installation program.
- 2 If a Security Warning window appears, click **Run**. The **Intermec End User License Agreement** appears.
- 3 Read and accept the agreement, and then click **Next**. The Installation Directory screen appears.
- 4 The default installation directory is C:\Intermec\InterDriver7. Click **Next** to use the default directory, or specify a different location to install the files, and then click **Next**. The Installation Information screen appears.
- 5 Clear the **Run Add Print Wizard after unpacking drivers** check box and click **Finish**.
- 6 On the New Hardware Wizard screen, select **Install from a list or specific location**, and then click **Next** to continue.



Note: For LPT connections, you must restart your computer for Windows to detect the new hardware. For USB connections, the New Hardware Wizard starts automatically when the printer is connected and turned on.

- 7 On the Search and Installation Options screen, click **Next**.
- 8 On the Hardware Installation warning screen, click **Continue Anyway**.

- 9 Click **Finish** to close the New Hardware Wizard. InterDriver files are now installed on your computer.
- 10 Connect the USB cable to the connector on the back of the printer and connect the other end to your PC.

Connecting the Printer Through the Serial Port

You can use a serial connection to communicate with your PC and run PrintSet, LabelShop, or InterDriver. You can also use the serial port to send commands directly to the printer through a serial communications program like HyperTerminal.

The serial communication parameters control the communication between the printer and the PC, referred to as “uart1:” on the printer. Make sure the serial port settings on the printer match the settings on the connected device. The default serial communication settings on the printer are: 115200 baud rate, 8 data bits, no parity, 1 stop bit, and no flow control.

To connect the printer to your PC using the serial port, you need a separately purchased serial cable (P/N 075497).

To connect the printer through the serial port

- 1 Connect the serial cable to the connector on the back of the printer and connect the other end to your PC.
- 2 On your PC, start the communications program.
- 3 If necessary, configure the PC port settings as follows:

Parameter	Default Setting
Baud rate	115200
Data bits	8
Parity	None
Stop bits	1

- 4 If you are using HyperTerminal
 - a Click the **Settings** tab.
 - b Click **ASCII Setup**. The ASCII Setup window appears.

- c** Select the following check boxes:
 - **Send line ends with line feed**
 - **Echo typed characters locally**
 - **Append line feeds to incoming line ends**
 - d** Click **OK** to save and close ASCII Setup.
 - 5** Test your connection by typing one of the following commands in your communications program window:
 - For IPL, hold down **Ctrl** and type:
b, w, c
 - For FingerPrint, type:
FF
and press **Enter**.
 - For ESC/P, press **ESC** and type:
EZ {AHEAD:10}
- The printer feeds a small strip of media.

Connecting the Printer to Your Network

The printer must establish communications with a host that sends the data to print. The printer has two ways to communicate with a network:

- Bluetooth radio communications
- 802.11 b/g wireless radio communications

Setting Up Bluetooth Communications

Your mobile printer contains a Bluetooth radio that allows wireless communications with a remote device from distances up to 100 meters (328 feet) depending on the Bluetooth range capabilities of the remote device, environmental conditions, and obstructions. For the Bluetooth-enabled devices to exchange data, both devices must establish a connection. Bluetooth software is always running in the background.

A printer cannot initiate a Bluetooth connection. The other device, such as a mobile computer, must request a connection with the printer. The printer then accepts or rejects the connection. Use Intermec Settings on the mobile computer to enable the Bluetooth settings on the printer.

If the printer has a Bluetooth connection, it can also connect to Bluetooth scanners, such as the SF51 and the SR61 Cordless scanners. You can create the bar code labels you need to connect the printer to a Bluetooth scanner using EasySet software. To create these bar codes, you need to know the Bluetooth Device Address (BDA) and the PIN of the printer. You can download a free version of EasySet from the Intermec website at www.intermec.com.

Each printer equipped with a Bluetooth radio has a unique BDA. You can find the BDA on the certification label located on the bottom of the printer.

For information on how to set up Bluetooth communications with your mobile computer, see your mobile computer user manual.





Note: For maximum security, Intermec recommends that you set a Bluetooth passcode. The default passcode is **1234**.

To set up Bluetooth communications with a scanner

- 1 Download and install EasySet.
- 2 Create the following bar code labels using EasySet:
 - Administrator reset factory defaults
 - Bluetooth parameters - security - not active
 - Bluetooth parameters - connect/disconnect - compose BT address
 - Bluetooth parameters - security - compose PIN:

- 3 Scan the bar code labels with the Bluetooth scanner.

Icon	Description
	The Bluetooth radio is on and the printer is not connected to a serial cable.
	The Bluetooth radio is off. The Bluetooth radio turns off when you connect a serial cable.

Setting Up 802.11 Radio Communications

The printer can have an internal 802.11 b/g radio to transfer and receive data using wireless communications. This manual assumes that you have already set up your wireless communications network, including at least one access point. The following procedures include information on setting up wireless security for IPL and Fingerprint.

The printer supports these authentication modes: none, WEP, WPA Personal and Enterprise mode (802.1x authentication), WPA2 Personal and Enterprise mode (802.1x authentication).



Note: WPA and WPA2 Enterprise mode currently support PEAP, TTLS, and LEAP. For LEAP authentication, the printer supports Open EAP, but does not support Network EAP.

To connect the printer to your wireless network, you need these items:

- Serial cable (P/N 075497-001)
- Host PC running Windows or Linux
- A communications application, such as Printset or HyperTerminal

To set up the printer for wireless communications using PrintSet

- 1 Connect the 8-pin circular DIN connector to the serial port on the printer. Connect the other end of the serial cable to a serial port on your PC.
- 2 On your PC, start PrintSet.
- 3 Select your printer from the My Printers list.
- 4 In the **Printer Tasks** list, click **Wireless Setup Wizard**. If you are prompted for the administrator username and password, type them and click **Next**.

- 5** If your wireless access point uses DHCP, select **Get TCP/IP parameters automatically**. If the access point does not use DHCP, select **Use the following TCP/IP parameters** and type the device **IP Address**, **Network Mask**, **Default Router** (default gateway), and **Name Server** (primary DNS server). Click **Next**.
- 6** Type the **SSID (Network Name)**. For peer-to-peer access points, select **This is an ad hoc network** and select the **Channel** you want to use. The channel setting must be the same on all wireless devices on the ad-hoc network. Click **Next**.
- 7** Select the security options required to connect to your wireless network. Click **Next**.
- 8** If you selected **Static WEP**, **Dynamic WEP (802.1x)**, or **Wi-Fi Protected Access** in Step 7, type the WEP keys or network credentials required for authentication. Click **Next**.
- 9** Wait for PrintSet to apply your settings. Click **Next**, then click **Finish** to complete the wizard.

To set up the printer for wireless communications using a communications program

- 1** Connect the 8-pin circular DIN connector to the serial port on the printer.
- 2** Connect the other end of the serial cable to a serial port on the back of your PC or to a serial adapter on your mobile computer.
- 3** Open a communications program such as HyperTerminal on your PC and configure the following parameters for the serial port:

Parameter	Default Setting
Baud rate	115200
Data bits	8
Parity	None
Stop bits	1

- 4 From the host PC, check the wireless settings.

If you have an IPL version of the printer, send these commands to the printer:



```
<STX><SI>wt , SSID<ETX>  
<STX><SI>wt , WEP1<ETX>  
<STX><SI>wt , WEP2<ETX>  
<STX><SI>wt , WEP3<ETX>  
<STX><SI>wt , WEP4<ETX>  
<STX><SI>wt , AUTH<ETX>  
<STX><SI>wt , WPA<ETX>  
<STX><SI>wt , WPA2<ETX>  
<STX><SI>wt , WPA_PSK<ETX>  
<STX><SI>wt , ROAM<ETX>  
<STX><SI>wt , PWR_MODE<ETX>  
<STX><SI>wt , CHANNEL<ETX>  
<STX><SI>wt , AP_MAC<ETX>  
<STX><SI>wt , SIGNAL<ETX>  
<STX><SI>wt , SPEED<ETX>  
<STX><SI>wt , ACTIVE<ETX>
```

If you have a Fingerprint version of the printer, send this command to the printer:



```
setup write "wlan", "uart1:"
```

- 5 Configure the printer to use the correct SSID and authentication mode.
- 6 If you use a certificate for wireless authentication and encryption, transfer the certificate to the printer. The printer can accept .pfx, .pem, and .der certificates.
- 7 Verify that the printer is connected to the access point and make sure it can get an IP address.

Understanding the 802.11 Radio Icons

Icon	Description
	Excellent signal
	Strong signal
	Good signal

Understanding the 802.11 Radio Icons (continued)

Icon	Description
	Weak signal
	Poor signal
	No signal

Use the following sections to set most of your wireless communication settings. For help with additional commands and information, see either the *Fingerprint Command Reference Manual* or the *IPL Command Reference Manual*. You can download both documents from the Intermec website at www.intermec.com.

Configuring Wireless Printing Using IPL

Use the following procedures to configure your printer with IPL for wireless printing.

To configure the printer to use WEP authentication

- 1 Send the following commands to login as an admin and set the SSID:

```
<STX><ESC>.x,su -p pass admin<ETX>
<STX><SI>ws,SSID,xxxxxx<ETX>
```

where *xxxxxx* can be from 0 to 32 ASCII characters, not including the double quote.



Note: The default administrator password is “pass.” If you have changed the password, use your password instead of “pass.”

- 2 Send the following commands to configure the WEP keys. The following example sets WEP key 1 to 1234 and enables WEP key 1.

```
<STX><SI>ws,WEP1, 0x0001020304<ETX>
<STX><SI>ws,.WEP_KEY,1<ETX>
```

- 3 Send the following command to activate the settings:

```
<STX><SI>ws,ACTIVE,1<ETX>
```

To configure the printer to use WPA-PSK or WPA2-PSK mode

- 1 Send the following commands to log in as an administrator and set the SSID:

```
<STX><ESC>.x,su -p pass admin<ETX>  
<STX><SI>ws,SSID,xxxxx<ETX>
```

where *xxxxxx* can be from 0 to 32 alphanumeric characters.

- 2 Send one of the following commands to turn on WPA or WPA2 authentication. Send the WPA-PSK or WPA2-PSK command to set a pre-shared key:

```
<STX><SI>ws,WPA,ON<ETX>  
<STX><SI>ws,WPA2,ON<ETX>  
<STX><SI>ws,WPA_PSK,xxxxxxxxxxxx<ETX>
```

where *xxxxxxxxxxxx* is a value between 8 and 64 characters.

- 3 Send the following command to activate the settings:

```
<STX><SI>ws,ACTIVE,1<ETX>
```

To configure the printer to use WPA or WPA2 Enterprise mode

- 1 Send the following commands to log in as an administrator and set the SSID:

```
<STX><ESC>.x,su -p pass admin<ETX>  
<STX><SI>ws,SSID,xxxxx<ETX>
```

where *xxxxxx* can be from 0 to 32 alphanumeric characters.



Note: The default administrator password is “pass.” If you have changed the password, use your password instead of “pass.”

- 2 Send one of the following commands to enable WPA-802.1x or WPA2-802.1x authentication. You should also send the WPA_PSK command that does not contain a value:

```
<STX><SI>ws,WPA,ON<ETX>  
<STX><SI>ws,WPA2,ON<ETX>  
<STX><SI>ws,WPA_PSK,<ETX>
```

- 3 Send these commands to configure the EAP_TYPE:

```
<STX><SI>ws,EAP_TYPE,xxxx<ETX>
```

where *xxxx* can be OFF, LEAP, PEAP, or TTLS.

```
<STX><SI>ws,.EAP_USER,xxxx<ETX>  
<STX><SI>ws,.EAP_PASS,xxxx<ETX>
```

where *xxxx* is the unique username and the unique password for this protocol.

- 4 If you are using TTLS, you may need to send this command to set the TTLS outer name:

```
<STX><SI>ws, TTLS_USER, xxxx <ETX>
```

where *xxxx* is the outer name.

- 5 If you are using certificates for authentication, you may need the following commands.

- Send the following commands to set a certificate and enable validation:

```
<STX><SI>ws, CA_CERT, c:/testCA.pfx@export<ETX>  
<STX><SI>ws, VALIDATE, ON<ETX>
```

where *c:/testCA.pfx* is the location and name of the certificate and *export* is the passphrase.

- Send the following commands to set a common name for server 1 and server 2:

```
<STX><SI>ws, .SERVER_CN1, xxxxxxxxxxxx <ETX>  
<STX><SI>ws, .SERVER_CN2, xxxxxxxxxxxx <ETX>
```

where *xxxxxxxxxxx* can be a value from 0 to 64 characters.

- Send the following command to make sure your values match those used by the access point:

```
<STX><SI>wt, [variable name] <ETX>
```

All variables are returned with the exception of EAP_PASS, which always returns “****” if configured, and CA_CERT, which transmits the name of the last certificate authority successfully installed. An additional read-only variable for the supplicant state, called STATE, is also returned.

- You may need to send the following command several times for the wireless station to connect:

```
<STX><SI>ws, ACTIVE, 1<ETX>
```

Configuring Wireless Printing Using Fingerprint

Use the following procedures to configure your printer with Fingerprint for wireless printing.

To configure the printer to use WEP authentication

- 1 Send the following commands to login as an administrator and set the SSID:

```
run"su -p pass admin"  
setup write "wlan", "uart1:"  
setup "wlan", "SSID", "xxxxxx"
```

where *xxxxxx* can be from 0 to 32 ASCII characters, not including the double quote.



Note: The default password for logging in as an admin is “pass.” If you have changed the password, you will need to use your password instead of “pass.”

- 2 Send the following commands to configure the WEP keys. The following example sets WEP key 1 to 1234 and enables WEP key 1.

```
setup "wlan", "WEP1", "0x0001020304"  
setup "wlan", ".WEP_KEY", "1"  
setup "wlan", "ACTIVE", "1"  
setup write "wlan", "uart1:"
```

To configure the printer to use WPA-PSK or WPA2-PSK mode

- 1 Send the following commands to login as an administrator and set the SSID:

```
run"su -p pass admin"  
setup write "wlan", "uart1:"  
setup "wlan", "SSID", "xxxxxx"
```

where *xxxxxx* can be from 0 to 32 alphanumeric characters.

- 2 Send one of the following WPA/WPA2 ON commands to turn on WPA or WPA2 authentication. Send the WPA-PSK or WPA2-PSK command to set a pre-shared key:

```
setup "wlan", "WPA", "ON"  
setup "wlan", "WPA2", "ON"  
setup "wlan", "WPA_PSK", "xxxxxxxxxxxxx"  
setup "wlan", "ACTIVE", "1"  
setup write "wlan", "uart1:"
```

where *xxxxxxxxxxxxx* is a value between 8 and 64 characters.

To configure the Printer to use WPA or WPA2 Enterprise mode

- 1 Send the following commands to login as an administrator and set the SSID:

```
run"su-p pass admin"  
setup write "wlan", "uart1:"  
setup "wlan", "SSID", "xxxxx"
```

where *xxxxx* can be from 0 to 32 alphanumeric characters.

- 2 Send one of the following WPA/WPA2 ON commands to set up WPA-802.1x or WPA2-802.1x authentication. You should also send the WPA_PSK command that does not contain a value:

```
setup "wlan", "WPA", "ON"  
setup "wlan", "WPA2", "ON"  
setup "wlan", "WPA_PSK", ""  
setup write "wlan", "uart1:"
```

- To view the 802.1x values, send this command:

```
setup write "8021x", "uart1:"
```

- 3 Send these commands to configure the EAP_TYPE:

```
setup "8021x", "EAP_TYPE", "xxxx"
```

where *xxxx* can be OFF, LEAP, PEAP, or TTLS.

```
setup "8021x", ".EAP_USER", "xxxx"  
setup "8021x", "EAP_PASS", "xxxx"
```

where *xxxx* is the unique username and the unique password for this protocol.

- 4 If you are using TTLS, you may need to send this command to set the TTLS outer name:

```
setup "8021x", "TTLS_USER", "xxxx"
```

where *xxxx* is the outer name.

- 5 If you are using certificates for authentication, here are some commands you may need to use.

- Send the following commands to set a certificate and enable validation:

```
setup "8021x", "CA_CERT", "c:/test.pfx@export"  
setup "8021x", "VALIDATE", "ON"
```

where *c:/test.pfx* is the location and name of the certificate and *export* is the passphrase.

- Send the following commands to set a common name for server 1 and server 2:

```
setup "8021x", ".SERVER_CN1", "xxxxxxxxxxxx"  
setup "8021x", ".SERVER_CN2", "xxxxxxxxxxxx"
```

where *xxxxxxxxxxxx* can be a value from 0 to 64 characters.

- Send the following command to make sure your values match those used by the access point:

```
setup write "8021x", "uart1:"
```

- You may need to send the following command several times for the wireless station to connect:

```
setup "wlan", "ACTIVE", "1"<ETX>
```

Configuring the Printer Settings

You can change the configuration settings of the printer from:

- the Control Panel, or display.
- the host PC using PrintSet.
- the host PC using the command line.
- the printer home page.
- the SmartSystems Console.

For more information on the IPL and Fingerprint menu systems, see [“IPL Setup Menu” on page 80](#).

Changing Configuration Settings from the Control Panel

You need to start Setup mode before you can change configuration settings from the Control Panel or display. For more information on starting Setup mode and navigating through the settings, see [“Understanding Setup Mode” on page 23](#).

The top levels of the Setup menu are organized in a one-way loop. Each level has several sub-levels.

Note: The Setup menu is not available when using ESC/P.





Note: If you have a Bluetooth or radioless printer, you do not see the NETWORK setup menu when using Fingerprint or IPL.

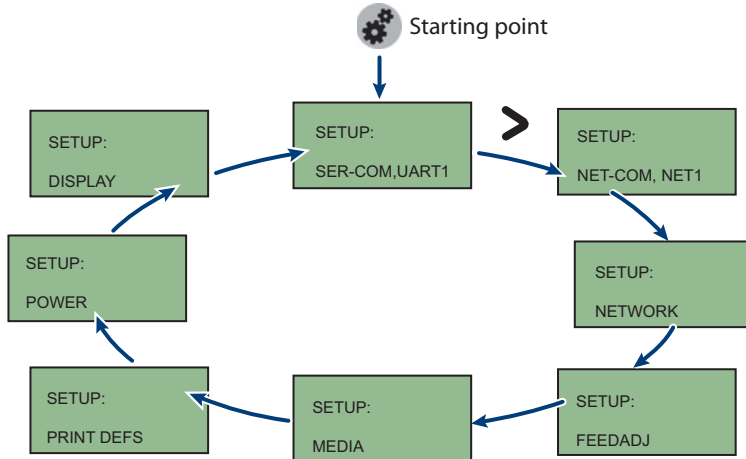

The Main Levels of the Setup Menu in Fingerprint

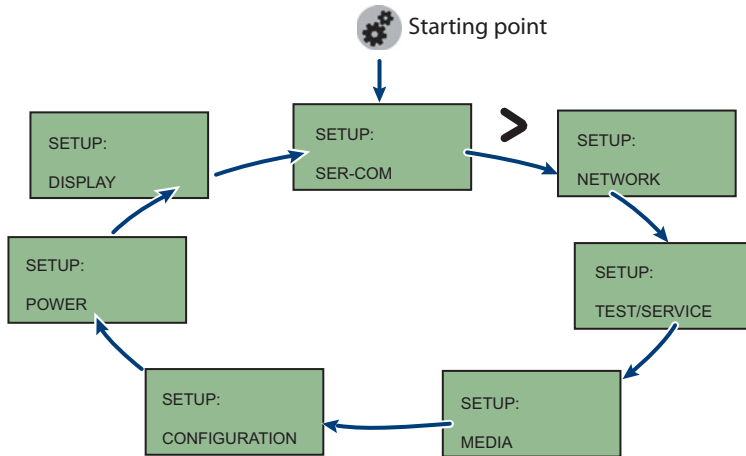

The Main Levels of the Setup Menu in IPL

Changing Configuration Settings From PrintSet

PrintSet Version 4.2 (or later) is a printer configuration tool that you can download from the Intermec website and install on a host PC. PrintSet communicates with your printer through a serial cable or a network connection on any PC with Windows 98 (or later). PrintSet allows you to easily change all of the setup parameters. It also includes setup wizards to guide you through some common configuration tasks. For more help using PrintSet, see the online help.

Changing Configuration Settings Using the Command Line

You can change configuration parameters by sending commands directly to the printer using a communications program like HyperTerminal and a serial or network connection.

If your printer uses the Fingerprint language, use the SETUP command, followed by the node, subnode, and parameters setting. Here is a Fingerprint example that sets your media setting to labels with gaps:

```
SETUP "MEDIA, MEDIA TYPE, LABEL (w GAPS) "
```

If your printer uses the IPL language, send the following command:

```
<STX><SI>T1<ETX>
```

Fingerprint automatically sends feedback to the communications program as you type. If you want to see what you are typing with IPL, you need to complete the following procedure.

To see IPL commands as you type

- 1 From the HyperTerminal menu, select **File > Properties > the Settings** tab.
- 2 Click the **ASCII Setup** button.
- 3 Select **Echo typed characters locally**.
- 4 Click **OK** twice.

For more information on changing configuration settings, see either the *Fingerprint Command Reference Manual* or the *IPL Command Reference Manual*. You can download these documents from the Intermec website at www.intermec.com.

Changing Configuration Settings From the Printer Home Page

If you have a printer with an 802.11 wireless radio, you can change configuration settings from the home page of the printer.

To make changes to the configuration

- 1 Establish a connection between your printer and the network. For help see [“Setting Up 802.11 Radio Communications” on page 34](#).
- 2 Connect your PC to the same network that the printer is on.
- 3 If you are using Fingerprint or IPL, find the IP address:
 - a Press the **Setup** button.
 - b Press the **▶** until you reach **Network**.
 - c Press **OK** to select the Network menu.
 - d Press **▶** until you reach **IP address**.
 - e Press **OK** to view the IP address.
- 4 If you are using ESC/P, use a communications program to find the IP address.
 - a Start a communications program.
 - b In the communications program window, type:
`ESC{QST:NW}`
and press **Enter**. The IP address of the printer appears in the communications program window.
- 5 Start a web browser.

- In the address field, type your printer IP address and press **Enter**. The printer home page appears.



- Click **Login** and type your administrator name and password.
- On the printer home page, click **Configuration**.

For help with Fingerprint, IPL, ESC/P, or SmartSystems commands and information, see either the *Intermec Fingerprint Command Reference Manual*, the *Intermec Printer Language (IPL) Command Reference Manual*, the *ESC/P Programmer's Reference Manual*, or SmartSystems online help. You can download these documents from the Intermec website at www.intermec.com.

Changing Configuration Settings From the SmartSystems Console

You can use the SmartSystems Console to change configuration settings on your printer. The printer ships with the SmartSystems client preloaded. The console is part of SmartSystems Foundation, and is available from the Intermec website. To download SmartSystems Foundation, go to www.intermec.com/products/smrtsysfoundation/index.aspx.

Upgrading the Firmware

The latest firmware and software is available for download from the Intermec website at www.intermec.com. You can upgrade the firmware on your printer using:

- PrintSet. You can download PrintSet from the downloads page for the printer on the Intermec website at www.intermec.com.
- the printer home page.
- SmartSystems™.
- a communications program like HyperTerminal.



Warning

When upgrading your firmware, make sure the battery in the printer is fully charged. If the printer loses power during the upgrade, the printer can be permanently damaged.



Note: If you upgrade your printer firmware to version 11.5.0 or later, your printer is loaded with Intermec Printer Language (IPL), Fingerprint, ESC/P, ZSim, CSim, and DSin. The first time you start your printer after you upgrade your firmware, you are prompted to select a printer language. For more information, see **“Selecting the Printer Language” on page 6.**

Upgrading the Printer Firmware Using PrintSet

You can only upgrade your printer using PrintSet when the printer is running IPL, Fingerprint, or ESC/P printer languages. To upgrade the printer using PrintSet, you need to install PrintSet on your PC and use a serial cable (P/N 075497).

To upgrade the printer firmware using PrintSet

- 1 Connect your PC to your printer using a serial cable. For help, see **“Connecting the Printer Through the Serial Port” on page 31.**
- 2 Download and save the firmware (.bin) file you want to use.
 - a Go to www.intermec.com.
 - b Select **Products > Printers and Media > Printer Family > Printer Model.**
 - c Click the **Downloads** tab.

- d In the **OS/Firmware/Drivers** section, click the link to the latest version of firmware and download the files to your PC.
- 3 Open PrintSet. The Intermec PrintSet dialog box appears.

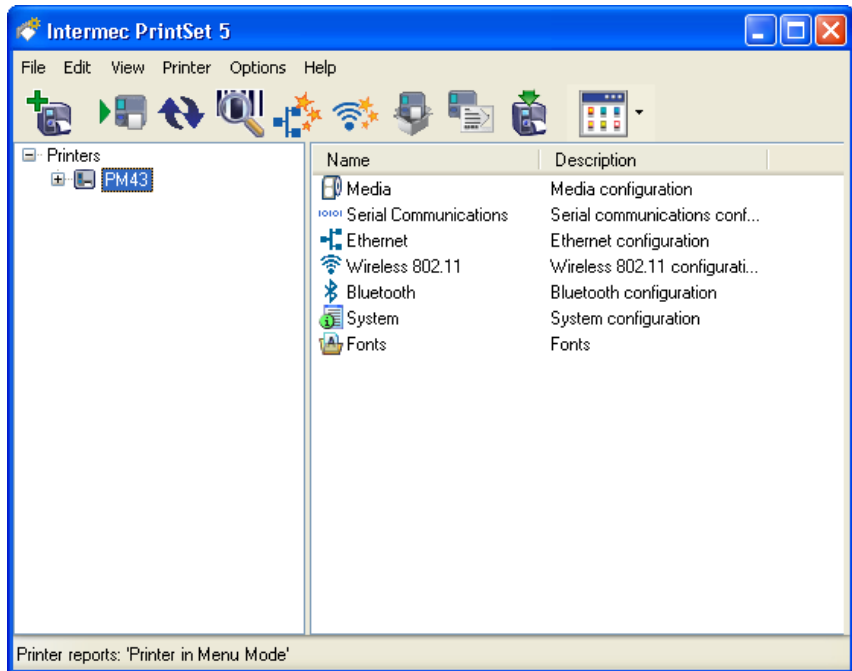

- 4 From the printer tree, select the printer you want to upgrade.

- 5 From the toolbar, click . The Firmware Upgrade Wizard appears. Click **Next**.

- 6 If your printer only supports firmware upgrades, the Select Firmware File window appears.

If your printer supports both firmware and bootloader upgrades, select **Firmware Upgrade**.



Caution

You should only select Bootloader Upgrade if you are told to do so by Intermec Product Support. Upgrading the bootloader unnecessarily may damage your printer.

- 7 Follow the onscreen instructions to upgrade your firmware.

If your printer is connected to your PC through a serial connection, the wizard displays the estimated download time.

When the upgrade is complete, your printer restarts.

Upgrading the Printer Firmware Using the Printer Home Page

You can upgrade your printer using the printer home page if you have a printer with an 802.11 radio, and are using IPL or Fingerprint.

To upgrade using the printer home page

- 1** Establish a connection between your printer and the network. For help, see **“Setting Up 802.11 Radio Communications” on page 34**.
- 2** Establish a connection between your PC and the network.
- 3** Download the firmware (.bin) file you want to upgrade to your PC.
 - a** Go to **www.intermec.com**.
 - b** Click **Support > Downloads**.
 - c** Use the **Product Category**, **Product Family**, and **Product fields**, to select the printer model.
 - d** Click **Submit**. The latest available software appears.
 - e** Download the latest firmware version to your PC.
 - f** Extract the .zip file to your PC.
- 4** If you are using Fingerprint or IPL, use the Control Panel to find the IP address of the printer.
 - a** Press the **Setup** button.
 - b** Press **➤** until **Network** appears.
 - c** Press **OK** to select the Network menu.
 - d** Press **➤** until you reach IP Address.
 - e** Press **OK** to select and view the IP Address.
 - f** Press the **Setup** button to return to Ready mode.
- 5** Start a web browser.

- In the **Address** text box, type the IP address of your printer and press **Enter**.



Name (WINS):	INTERMEC000000
Firmware Version:	MCS 1864, 12-Oct-07 14:16:56
Active Command Set:	FP 11.1.0 Beta3
MAC Address:	00:1A:73:40:93:EF
IP Address:	10.20.111.211
Image buffer:	label.png
RtW™:	Operational

- Click **Maintenance**. The Maintenance page appears.

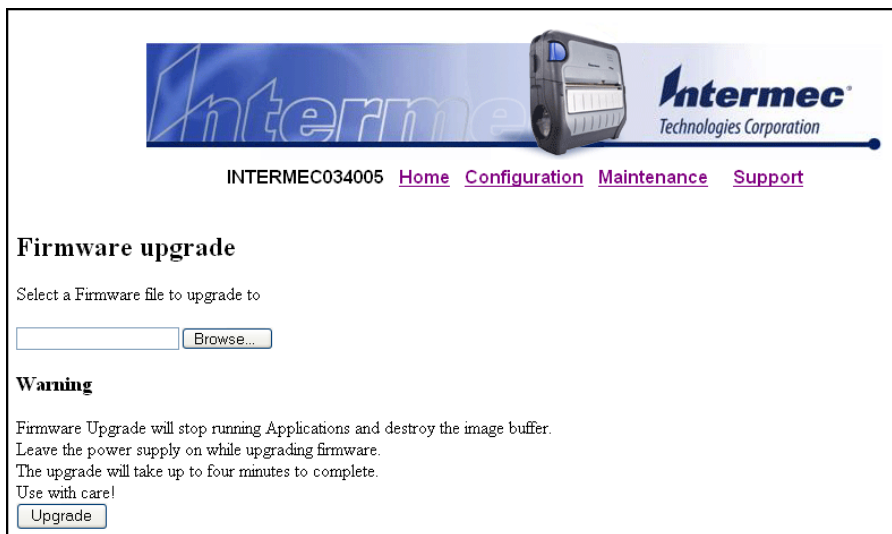

Firmware upgrade

Select a Firmware file to upgrade to

Warning

Firmware Upgrade will stop running Applications and destroy the image buffer.
Leave the power supply on while upgrading firmware.
The upgrade will take up to four minutes to complete.
Use with care!

- 8** When prompted, type your user name and password. The default user name is “admin” and the default password is “pass.”
- 9** Browse to the (.bin) file you want to upgrade to and select it.
- 10** Click **Upgrade**.

Wait approximately five minutes for the firmware upgrade to complete. The printer automatically restarts.

Upgrading Printer Firmware Using SmartSystems Foundation

You can use the SmartSystems console to upgrade the printer firmware. Your printer ships with the SmartSystems client preloaded. The console is part of SmartSystems Foundation, and is available from the Intermec website. To download SmartSystems Foundation, go to www.intermec.com/products/smrtsysfoundation/index.aspx.

Upgrading the Printer Firmware Using a Communications Program

You can upgrade your printer firmware using a communications program, such as HyperTerminal, and a printer running either the IPL, Fingerprint, or ESC/P printer language.



Note: Intermec recommends that you upgrade your printer firmware using PrintSet or the home page of the printer.

To upgrade the printer firmware using a communications program and IPL

- 1** Connect your printer to your PC using a serial cable. For help, see [“Connecting the Printer Through the Serial Port” on page 31](#).
Or, establish a connection between your printer and your network. For help, see [“Connecting the Printer to Your Network” on page 32](#).
- 2** If you connected your printer to the network, establish a connection between your PC and the network.

- 3** Download the firmware (.bin) file you want to upgrade to your PC.
 - a** Go to www.intermec.com.
 - b** Click **Support > Downloads**.
 - c** Use the **Product Category**, **Product Family**, and **Product fields**, to select the printer model.
 - d** Click **Submit**. The latest available software appears.
 - e** Download the latest firmware .zip file to your PC.
 - f** Extract the .bin file to your PC.
- 4** Open a communications program.
- 5** In the window, type:
`<STX><ESC>.y,ush<ETX>`
and press **Enter**. You will be prompted for more data.
- 6** In the window, type:
`su -p pass admin.`
and press **Enter**.
- 7** In the window, type:
`dlk -z`
and press **Enter**.
The printer shows the “Upgrading” message.
- 8** In the communications program window, click **Transfer > Send File**. A dialog box appears.
- 9** From the protocol drop-down list, select **Zmodem**.
- 10** Browse to the firmware (.bin) file you want to upgrade to and select it.

Wait approximately five minutes for the firmware upgrade to complete. When the upgrade is complete, the communications program shows the “Kernel flashing OK” message and the printer automatically restarts.

To upgrade the printer firmware using a communications program and Fingerprint

- 1 Connect your printer to your PC using a serial cable. For help, see **“Connecting the Printer Through the Serial Port” on page 31.**
- 2 Download the firmware (.bin) file you want to upgrade to your PC.
 - a Go to www.intermec.com.
 - b Click **Support > Downloads**.
 - c Use the **Product Category, Product Family, and Product fields**, to select the printer model.
 - d Click **Submit**. The latest available software appears.
 - e Download the latest firmware version to your PC.
 - f Extract the .zip file to your PC.
- 3 Open a communications program.
- 4 In the window, type:

```
run "su -p pass admin"
```

and press **Enter**.
- 5 In the window, type:

```
run "dlk -z"
```

and press **Enter**.

The printer screen shows the “Upgrading” message.
- 6 In the communications program window, click **Transfer > Send File**. A dialog box appears.
- 7 From the protocol drop-down list, choose **Zmodem**.
- 8 Browse to the firmware (.bin) file you want to upgrade to and select it.

Wait approximately five minutes for the firmware upgrade to complete. When the upgrade is complete, the communications program shows the “Kernel flashing OK” message and the printer automatically restarts.

To upgrade the printer firmware using a communications program and ESC/P

- 1 Connect your printer to your PC using a serial cable. For help, see **“Connecting the Printer Through the Serial Port” on page 31.**
- 2 Download the firmware (.bin) file you want to upgrade to your PC.
 - a Go to www.intermec.com.
 - b Click **Support > Downloads**.
 - c Use the **Product Category**, **Product Family**, and **Product fields**, to select the printer model.
 - d Click **Submit**. The latest available software appears.
 - e Download the latest firmware version to your PC.
 - f Extract the .zip file to a folder on your PC.
- 3 Open a communications program.
- 4 Restart the printer.
- 5 Press **Esc** and in the communications program window type:
`{SYS:USH}`
and press **Enter**.
- 6 In the window, type:
`su -pass admin`
and press **Enter**.
- 7 In the window, type:
`dlk -z .`
and press **Enter**.
The printer shows the “Upgrading” message.
- 8 In the communications program window, click **Transfer > Send File**. A dialog box will appear.
- 9 In the protocol drop-down box, select **Zmodem**.
- 10 Browse to the firmware (.bin) file you want to upgrade to and select it.

Wait approximately five minutes for the firmware upgrade to complete. When the upgrade is complete, the communications

program shows the “Kernel flashing OK” message, and the printer automatically restarts.

Downloading Fonts and Graphics

The easiest way to download fonts and graphics is to use PrintSet, the free Intermecc printer application. You can download PrintSet from the downloads page for the your printer on the Intermecc website at www.intermec.com. Follow the procedures in the PrintSet online help to download fonts and graphics.

You can also use Fingerprint, IPL, or ESC/P commands to send fonts and graphics to the printer. For help with commands and information, see the *Fingerprint Command Reference Manual*, the *IPL Command Reference Manual*, or the *ESC/P Programmer’s Reference Manual*. You can download these documents from the Intermecc website at www.intermec.com.

3

Troubleshooting and Maintaining the Mobile Printer

Use this chapter to solve problems you may encounter while using the printer. You will also find information on booting the printer and routine maintenance. This chapter contains these sections:

- **Troubleshooting the Mobile Printer**
- **Restarting the Mobile Printer**
- **Cleaning the Printer**

Troubleshooting the Mobile Printer

You may have printer operation, print quality, or printer communication problems at some time during the life of the printer. Most of the problems you encounter are easy to fix. For help, see “**Troubleshooting Printer Problems and Finding Solutions**” on [page 60](#). If you cannot find the answer to your problem, you may need to contact Product Support.

Contacting Product Support

Before you call Intermec Product Support, you may want to visit the Intermec technical knowledge base (Knowledge Central). To do so, go to www.intermec.com and click **Support > Knowledge Central**. If you still need help after visiting Knowledge Central, you may need to call Product Support.

To talk to an Intermec Product Support representative in the U.S.A. or Canada, call:

1-800-755-5505

Outside the U.S.A. and Canada, go to www.intermec.com and click **Contact Us** to find your local Intermec representative.

Before you call Intermec Product Support, make sure you have the following information ready:









- Printer serial number
- Firmware type and version
- Bluetooth, wireless, or serial port settings

You can find all of the information listed above in the printer menu system or on a testprint page.



Understanding Error Messages

Use the following tables to troubleshoot some common error messages. Some error messages appear only when you use a specified printer language.

Possible Printer Error Icons and Messages

Error Icon	Error Message	Description
	Pause	The print job is paused.
	Paper out (IPL) Out of Paper (Fingerprint)	The printer is out of paper. Load a new roll of media. For help, see “Loading Media” on page 14 .
	Testfeed not done	The printer did not perform a testfeed before it printed out test labels. It is important to perform a testfeed because it calibrates the printer sensors. To perform a testfeed: <ul style="list-style-type: none"> • Press the Feed button for more than 2 seconds (Fingerprint or ESC/P) • Open and close the media door, then press the Feed button (IPL)
	Printhead hot	The printhead is overheated and needs to cool down. In IPL, wait for printing to resume automatically. In Fingerprint and ESC/P, your print job is lost.
	Upgrading	The printer is loading new firmware.
	LSS too high LSS too low	These errors can occur when you run a test feed without any media installed, or if you have incorrect media settings. Load the printer with media (see “Loading Media” on page 14), run Test mode (see “Understanding Extended Test Mode” on page 25), and select the appropriate media type.
	IP configuration error	The printer does not have a network IP address. Wait for the printer to acquire an IP address before continuing.
	IP link error	The printer does not have a network connection.

Possible Printer Error Icons and Messages (continued)

Error Icon	Error Message	Description
	Field out of label	You are attempting to print in an area that extends beyond the print window. See the command reference manual for your type of firmware (IPL, Fingerprint, or ESC/P) for information on how to set the media parameters.
	Printhead lifted	The printer is not closed. Press down on the media cover to make sure it is latched.

Troubleshooting Printer Problems and Finding Solutions

Use the following tables to troubleshoot some common problems you may encounter with the printer.

Printer Problems and Solutions

Problem	Possible Solution
The printer does not turn on when you press Standby .	<ul style="list-style-type: none"> • Replace the battery with a charged battery. • Connect external power to make sure the printer works correctly and to charge the battery.
The blue light (Ready-to-Work indicator) is blinking.	<ul style="list-style-type: none"> • Make sure media is loaded and the media cover is closed. For help, see “Loading Media” on page 14. • There is a printing error. The screen shows an error message containing information on the error. • The printer is paused. The printer is cancelling a print job.
The printer keeps printing or feeding when it should stop.	<ul style="list-style-type: none"> • Check media settings. • Make sure the label gap sensor is clean. For help, see “Cleaning the Printer” on page 65.
The printout is not in the desired position.	<ul style="list-style-type: none"> • Check for errors in the software application. • Make sure the label gap sensor and platen roller are clean.

Printer Problems and Solutions (continued)

Problem	Possible Solution
The printer is not printing with an 802.11 wireless connection.	<ul style="list-style-type: none"> • Verify that the wireless settings are correct. For help, see “Setting Up 802.11 Radio Communications” on page 34. • Make sure the printer has an IP address. • Make sure the printer is connected to the network. • Make sure the printer is in Ready mode.
The printer is not printing with a Bluetooth connection.	<ul style="list-style-type: none"> • Re-establish a Bluetooth connection with the mobile computer or scanner. For help, see your mobile computer user manual or “Setting Up Bluetooth Communications” on page 32. • Make sure the mobile computer can print to a known good printer. • Print a Bluetooth testprint page to make sure that the mobile printer discovered your printer. For help, see “Printing a Test Page” on page 26. • Make sure the printer is in Ready mode.
When printing, the printer is skipping labels.	<p>Perform a testfeed:</p> <ul style="list-style-type: none"> • In Fingerprint or ESC/P, press the Feed button for more than 2 seconds. • In IPL, open and close the media door and then press the Feed button. • Make sure the label gap sensor is clean. For help, see “Cleaning the Printer” on page 65.
The printout is faded or weak.	<ul style="list-style-type: none"> • In Fingerprint, adjust the media constant/factor and contrast (-10% to +10%). • In IPL, adjust the media sensitivity setting (-10 to +10). • In ESC/P, adjust the darkness. • Check to see if the printhead needs cleaning. For help, see “Cleaning the Printer” on page 65.
The battery charge is not lasting as long as it should.	<ul style="list-style-type: none"> • Check the battery date. If the battery is a few years old, the shortened life may be due to normal aging. • Replace the battery.

Printer Problems and Solutions (continued)

Problem	Possible Solution
The test pages do not print.	<ul style="list-style-type: none">• Make sure that the Ready-to-Work indicator is not blinking. If it is, make sure your printer has media and that the media cover is closed.• Make sure that you can advance media by pressing the Feed button.
The print quality is poor.	<ul style="list-style-type: none">• Clean the printhead. For help, see “Cleaning the Printer” on page 65.• Check the battery and recharge or replace as necessary. For help, see “Charging the Batteries” on page 11.• Check the quality of the media. Use only Intermec media to ensure superior print quality and product performance.• Check that the printer is set to the appropriate Constant/Factory or sensitivity number for the media you are using.
Your printer cannot connect to PrintSet or HyperTerminal	<ul style="list-style-type: none">• Make sure that the serial or USB cable is plugged in correctly.• Check to make sure that all pins on the serial cable are straight and not bent.

Troubleshooting Communication Problems

Use Dump mode to verify that the printer is receiving data from the host correctly.

Using the Line Analyzer in Fingerprint

In Dump mode, the printer runs a Fingerprint program called Line Analyzer. The Line Analyzer captures incoming characters on the communication ports and prints them on one or more labels.

After the printer starts Dump mode, it tells you it has started Dump mode by printing it on a label. The Dump mode icon appears and printer is ready to receive data. For more information on how to start Dump mode, see **“Understanding Dump Mode” on page 24**.

While the printer is receiving data, the Ready-to-Work indicator blinks. After a half of a second, if no more characters have been received, the printer times out. The program considers the transmission terminated and prints out a label.

In Dump mode, by default, printable characters print in black-on-white. Control characters and space characters (ASCII 000 to 032 dec) print in white-on-black.

As long as a continuous string of characters are being received, the program wraps the lines until the label is full and then starts to print another label. After each character transmission, the following information prints:

- Page number
- Number of characters printed on the label
- Total number of characters received so far

When you stop Dump mode, a final label prints to inform you that the printer is exiting from Dump mode.

Using Dump Mode in IPL

When you start Dump mode, the printer captures incoming characters on the communication ports and prints them on one or more labels.

If you are using IPL, you can start Dump mode in two ways. Each way produces slightly different results. You can start Dump mode:

- from Ready mode or Extended Test mode. Printouts are exactly like those produced with the Line Analyzer program in Fingerprint. For more information, see the previous procedure, **“Using the Line Analyzer in Fingerprint” on page 62.**
- using the Control Panel buttons. Characters are printed on a continuous line along with their corresponding hexadecimal numbers.

For information on how to start Dump mode from Extended Test mode, see **“Understanding Extended Test Mode” on page 25.**

To start Dump mode from Ready mode with IPL

- Press and hold the **Feed** and **Standby** buttons until the printer starts feeding out media.

The printer feeds several labels (or inches of media), prints the test labels, and then starts Dump mode.

To stop Dump mode

- Press the **Feed** button.

Restarting the Mobile Printer

You rarely need to cold boot the printer unless you are upgrading the firmware. If your printer occasionally locks up, you will want to cold boot it. A cold boot restarts the 802.11 wireless radio and clears the working memory.



Note: The Setup menu is not affected by a cold boot. Your printer retains all of your configuration settings after the printer powers back up.

To restart the printer

- 1** Disconnect the printer from power if externally powered.
- 2** Remove the battery from the printer for at least one second.
- 3** Insert the battery back into the printer.
- 4** Reconnect external power if your printer is externally powered.

Cleaning the Printer

To properly maintain your printer, you must clean it at the recommended interval. Make sure to clean the following parts:

- Printhead
- Platen roller
- Paper sensors
- Tear bar
- Printer exterior
- Media compartment



To avoid possible personal injury or damage to the printer, never insert any pointed or sharp objects into the printer.



Use only the cleaning agents specified in this section. Intermec is not responsible for damage caused by any other cleaning materials used on this printer. Clean most of the printer with a cotton swab saturated with alcohol.



Do not clean the linerless platen roller with isopropyl alcohol. It could damage the surface of the platen roller.

Use the following illustration to locate the parts of your printer to clean.

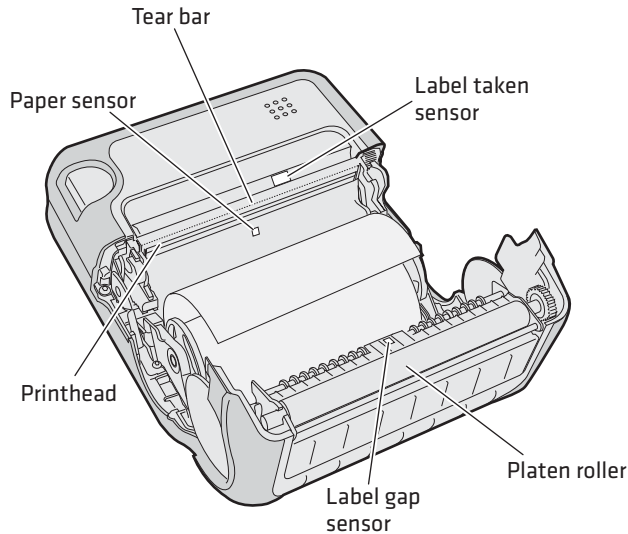

PB50 and PB51 Mobile Label and Receipt Printer: Identifying the parts of the printer to clean regularly

Cleaning the Printhead

Clean the printhead after printing five rolls of media to prolong the life of the printhead and ensure high print quality.

Clean the printhead with the cleaning swab or cleaning pen. The cleaning swab is shipped with the printer and can also be purchased separately from www.intermec.com.



Note: Intermec recommends that you use only the cleaning swab or cleaning pen for this task. Using other methods or tools to clean the printhead and platen roller can damage the printer.

To clean the printhead

- 1 Open the media cover.
- 2 Remove the media and ribbon.
- 3 Use the cleaning swab or cleaning pen to dissolve any contamination on the line of heat-emitting objects at the front or bottom of the printhead.

- 4** Wait 30 seconds and carefully rub off any contamination.
- 5** Repeat Steps 3 and 4 if necessary.
- 6** Allow the printhead to dry completely before loading new media and ribbon.

Cleaning the Platen Roller

Clean the platen roller after printing five rolls of media to prolong the life of the printhead and ensure high print quality.

Clean the printhead with the cleaning swab. One cleaning swab is shipped with the printer, and you can purchase additional cleaning swabs from www.intermec.com.



Note: Intermec recommends that you use only the cleaning swab for this task. Using other methods or tools to clean the printhead and platen roller can damage the printer.

To clean the platen roller

- Rotate the platen roller and clean it thoroughly with the cleaning swab.

When you clean the platen roller, also clean the paper sensors and tear bar using the cleaning swab.

Cleaning the Printer Exterior

Make sure that the exterior of the printer is clean to reduce the risk of dust and other particles reaching the inside of the printer. Dust particles can reduce print quality and cause other problems.

To clean the printer exterior

- 1** Close the media cover.
- 2** Using a soft cloth, wipe the printer exterior. You can also use a small amount of water or mild detergent.

Intermec recommends that you keep the surface surrounding the printer clean.

Cleaning the Printer Media Compartment

- 1** Open the media cover.
- 2** Remove the media and ribbon.
- 3** Use a brush or air blow the compartment.
- 4** Make sure the paper sensors are free of dust.

A

Specifications

Specifications

Physical Dimensions

Depth:	78.7 mm (3.1 in)
Height:	174.5 mm (6.9 in)
Width:	159.5 mm (6.3 in)
Weight:	1190 g (2 lb) with battery

Power Specifications

AC power adapter voltage:	100 V to 240 V
Printer voltage:	100 V to 240 V and 50 Hz to 60 Hz
Operating power:	Rechargeable 16.8 V 2200 mAh lithium-ion battery

Temperature and Humidity Specifications

Operating temperature:	-15 °C to 50 °C (5 °F to 122 °F)
Storage temperature:	-22 °C to 70 °C (-30 °F to 158 °F)
Charging temperature:	0 °C to 45 °C (32 °F to 113 °F)
Relative humidity:	0% to 95% non-condensing
Sealing:	IP54. The paper path and slots are excluded from IP54.

Memory

RAM:	16 MB
Flash:	64 MB

Print Speed and Resolution

Print speed:	up to 4 ips (100 mm/s)
Resolution:	203 dpi (8 dots/mm)

Print Technology

Printhead:	Direct thermal
Maximum print width:	108 mm (4.25 in)

Media Specifications

Core inside diameter, standard:	19 mm (0.75in)
Core inside diameter, with adapter:	10.2 mm (0.4 in)
Maximum roll outside diameter:	67.3 mm (2.65 in)
Media width, label with liner/receipt:	49mm (1.9 in) to 111.5 mm (4.4 in)
Media length, label:	25.4 mm (1.0 in) to 609.6 mm (24 in)
Media length, receipt:	Continuous
Media caliber, label with liner/receipt:	0.05 mm (0.002 in) to 0.165 mm (0.0065 in)
Media caliber, tag (maximum):	0.15 mm (0.006 in)
Gap length (centered on perforation):	3.17 mm (0.125 in) to 12.7 mm (0.50 in)
Notch length (centered on perforation):	6.35 mm (0.25 in)
Notch width (centered on perforation):	12.7 mm (0.50 in)
Black mark length (centered on perforation):	3.17 mm (0.125 in) to 12.7 mm (0.50 in)
Black mark width (centered on media width):	Full width of media

Receipt roll stock media is supplied as a continuous roll. Label, tag, and fanfold media use repeat indicators for non-continuous media. Gap, notch, and black marks are used as repeat indicators:

- Gap: Label and fanfold media
- Notch: Tag media
- Black mark: Label, tag, and fanfold media

Appendix A – Specifications

Keep these tips in mind when ordering media for the printer:

- The PB51 printer can detect black marks only on the front side of the media. The PB50 can detect black marks on both sides.
- You can use higher-caliber media in the printer, but print quality will be reduced.
- Receipt roll stock media has an end of roll indicator. The end of roll indicator is a red marking (on last 3 feet of roll) on the thermally sensitive side of the paper.

External Fanfold Media Specifications

Stack height:	70 mm (2.75 in)
Page length:	152 mm (6 in) to 305 mm (12 in)



Note: A 6-inch page length is supplied in 12-inch long stacks (two 6-inch stacks of equal height with the bottom page linked).

Specialty media is required for unique customer environments, including printing in extreme temperatures. Media performance is dependant on format and environment. Not all media will work in all customer applications. Intermec recommends that you test the media in your application.

Supported Media Types

All models of the mobile printer support direct thermal label, tag, and receipt media. Both North American and European label media are supported in multiple label lengths. Receipt media is supported in both top coated and uncoated paper in continuous roll stock only.

The default media sensitivity is 180.

The default media sensitivity for linerless media is 103.

Use the following table as a guide when setting sensitivity.

Recommended Media Sensitivity, Constant, Factor, and Print Speed

Sensitivity	Constant	Factor	Description	Max Print Speed
North American Label Media				
720	60	40	Duratherm Lightning Plus	4 ips
470	52	40	Duratherm Lightning	4 ips
450	48	40	Duratherm Lightning	2 ips
430	100	40	Duratherm Synthetic	4 ips
180	80	40	Duratherm II Label	4 ips
180	80	40	Duratherm III Label	4 ips
180	80	40	Duratherm Near IR	4 ips
150	50	40	Duratherm 5 mil Tag	2 ips
North American Label Media (continued)				
103	110	45	Direct Thermal Linerless	Dependent on format and environment
North America Receipt Media				
401	45	40	Duratherm TC	2 ips
102	32	40	Duratherm NTC - 2	2 ips
101	30	40	Duratherm NTC	2 ips
European Label Media				
440	47	30	Thermal Eco	2 ips
140	70	40	Thermal Top	4 ips

Interfaces

This section describes the standard interfaces available on the PB50 and PB51 printers.

RS-232 Serial Interface

Use the following tables and graphics to understand serial port default settings

Serial Port Default Settings

Parameter	Default Setting
Baud rate	115200
Character Length or Data Bits	8
Parity	None
Stop Bits	1
Handshaking	none (Fingerprint XON/XOFF (IPL))

The following illustration shows the printer end of the serial cable.

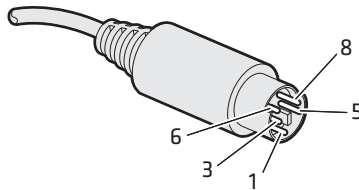

Serial Cable (Printer End)

Serial Cable Pins and Descriptions (Printer End)

Pins	Signal	Description
1	HHC RXD	Receive data from host (input)
3	HHC CTS	Clear to send from printer (output)
5	HHC RTS	Request to send from host (input)
6	HHC TXD	Transmit data to printer (output)
8	GND	Ground

The following illustration shows the PC end of the serial cable.

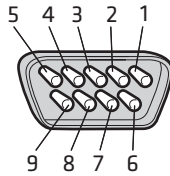

RS-232 Serial Cable DB9 Pins

Serial Cable Pins and Description (PC End)

Pin	Signal	Description
1	DCD	Data carrier detect
2	RXD	Receive data from host (input)
3	TXD	Transmit data to printer (output)
4	DTR	Data terminal ready
5	GND	Ground
6	DSR	Data set ready
7	RTS	Request to send from host (input)
8	CTS	Clear to send from printer (output)
9	RI	Ring indicator

USB Interface

To use the USB interface to print from a PC, you need to install the Intermec InterDriver printer driver on your PC. For help setting up USB communications, see **“Connecting the Printer Through the USB Interface” on page 30**.

The USB cable that ships with the printer has a USB Type A connector on one end to connect to the PC, and a USB Type B connector on the other end to connect to the printer. You do not need to configure communications for the USB port.

The following illustrations show the USB connector types.

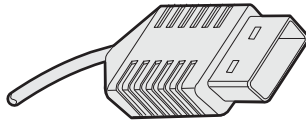

USB Type A Connector

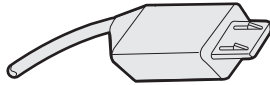

USB Type B Connector

Accessories for the Mobile Printer

You can use these accessories (sold and ordered separately) with the printer. To order accessories, contact your local Intermec sales representative.

4-Bay Battery Charger (Model AC18)

Use the AC18 to charge up to four batteries at a time. The battery charger is designed to sense when a battery is fully charged and not overcharge it, ensuring long and consistent battery life.

Battery (Model AB13)

Use the AB13 lithium-ion 2200 mAh battery to provide power to the printer.

Belt Clip

Use the printer belt clip to attach the printer to your belt.

Cart Dock

Use the cart dock to easily attach the printer to a movable cart or a flat surface.

Cleaning Pen

Use the cleaning pen to clean the printhead.

Cleaning Swab

Use cleaning swabs to clean the platen roller, paper sensor, tear bar, and printhead.

Forklift Power Supply Kit

Use the forklift power supply kit to connect the printer and vehicle cradle to a truck or forklift.

Handstrap

Use the printer handstrap to conveniently carry your printer. With the handstrap attached, you can also attach the printer shoulder strap.

Intermec Cleaning Swab

Use the Intermec cleaning swab to clean the printhead and platen roller. One cleaning swab is included with the printer. You can purchase additional cleaning swabs from www.intermec.com.

Power Supply (Model AE19)

Provides power to the mobile printer and the 4-bay battery charger (Model AC18).

Printhead Cleaning Pen

Use the cleaning pen to clean the printhead.

Protective Case

Use the protective case to transport and store your printer. The protective case keeps the printer free of dust, dirt, and moisture and still provides easy access to the printer for printing.

Serial Cable

The serial adapter is an 8-pin DIN to DB9 connector that connects your printer to your desktop PC.

Shoulder Strap

Use the shoulder strap, with the handstrap, to carry the printer. The wide padded strap makes it comfortable to wear the printer for long periods of time.

Vehicle Cradle (Model AV8)

Use the vehicle cradle to attach the printer to a truck or forklift. You will need the forklift power supply kit to connect your vehicle power to the printer.

B

IPL and Fingerprint Setup Menus

IPL Setup Menu

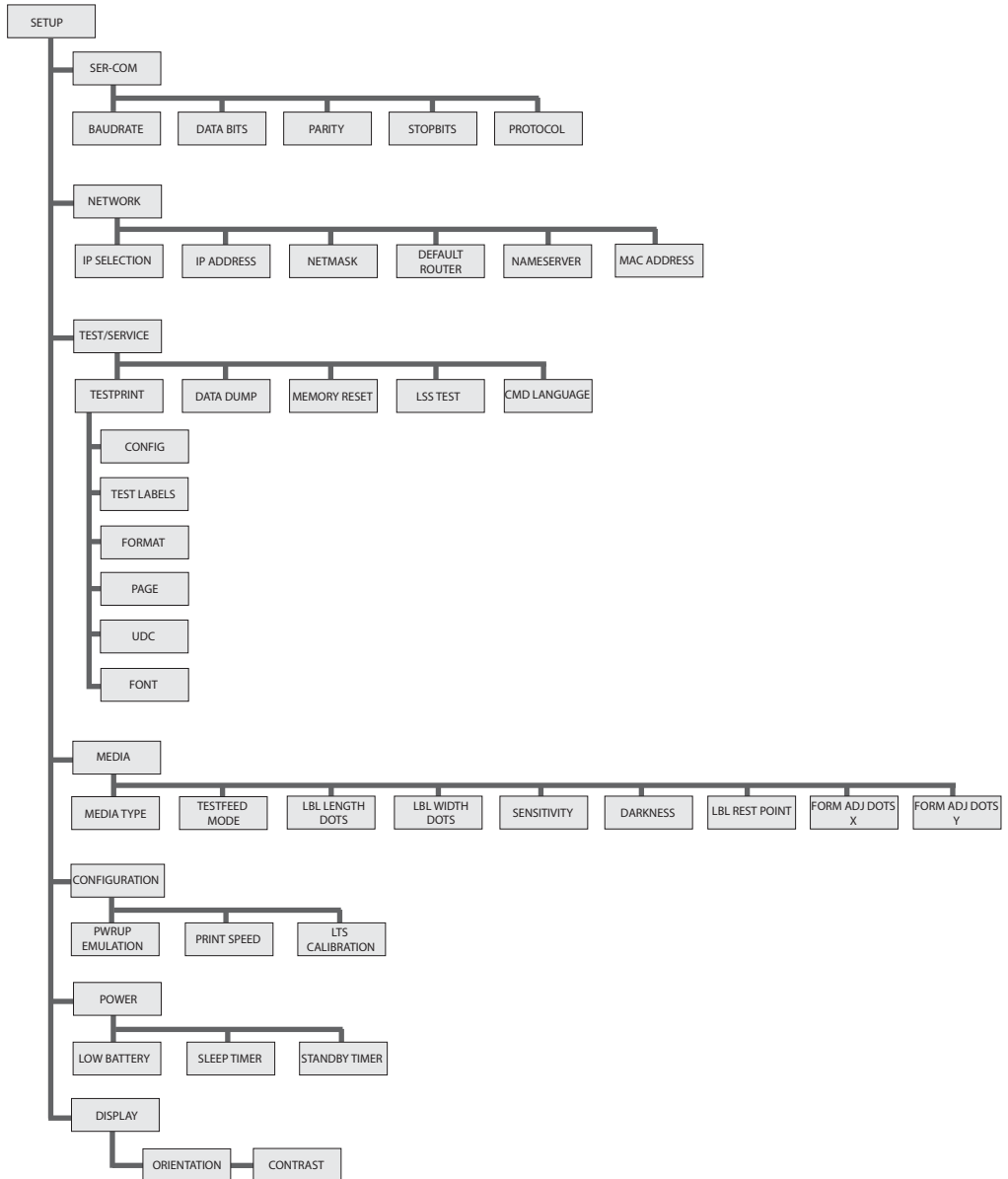

Fingerprint Setup Menu

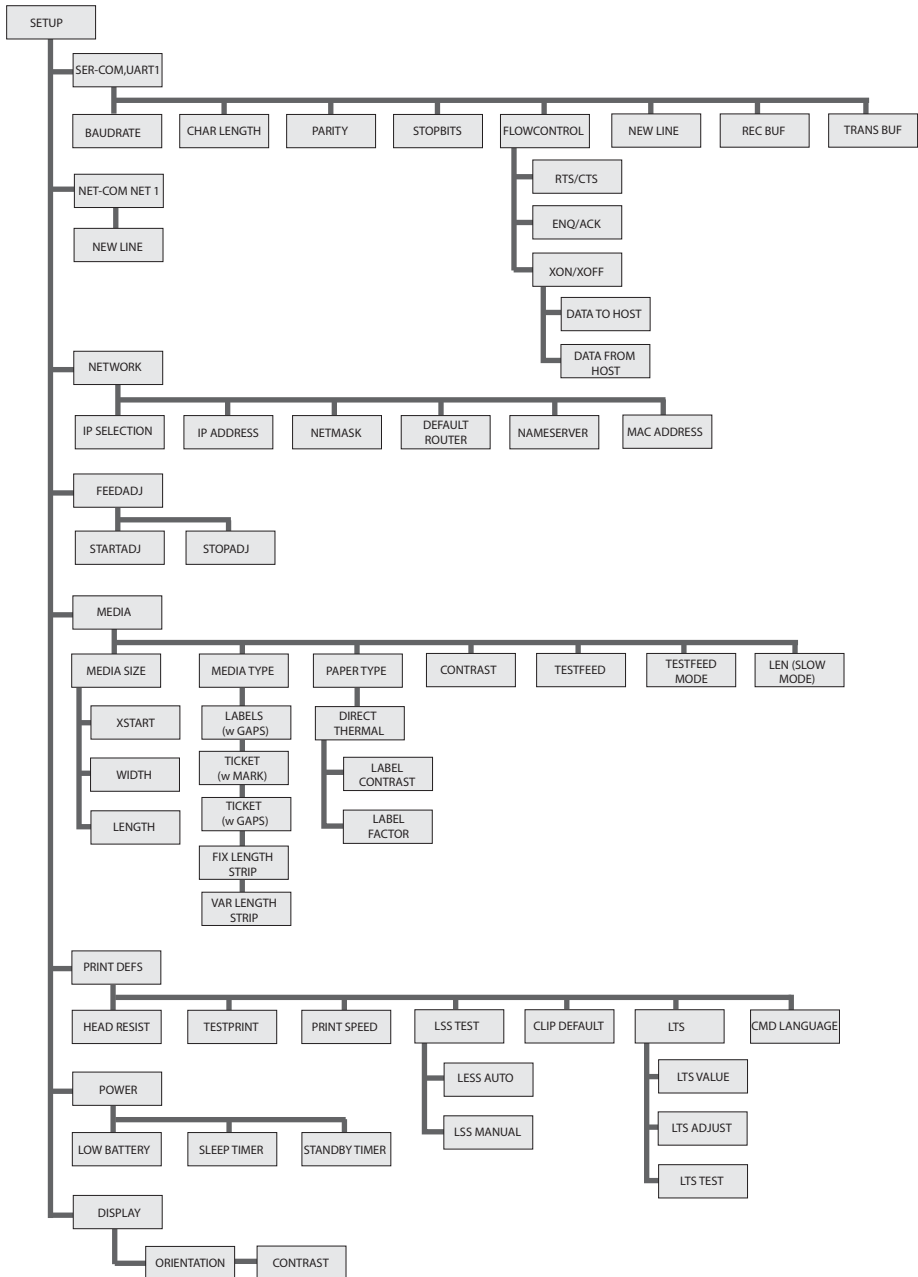

Appendix B – IPL and Fingerprint Setup Menus



Index

Numerics

- 802.11 wireless
 - authentication modes 34
 - configuring using Fingerprint 40–42
 - configuring using IPL 37–39
 - configuring using PrintSet 34
 - finding current settings 58
 - restarting 64
 - setting the pre-shared key 38, 40
 - setting the SSID 38, 40, 41
 - setting up communications 34–42
 - signal strength 36
 - status icons 36
 - troubleshooting 61
 - using certificates 36, 39, 41
 - WEP 37, 40
 - WPA or WPA2 Enterprise 38–39, 41–42
 - WPA-PSK or WPA2-PSK 38, 40

A

- AC18 4-bay battery charger 11, 13, 76
- accessories 76–77
 - See also* AC18 4-bay battery charger; AE19 power supply; AV8 vehicle cradle; battery
- administrator password 37, 38, 40
- AE19 power supply 11, 77
- AV8 vehicle cradle 77

B

- battery
 - capacity 9, 61
 - charging error 11
 - charging guidelines 11, 13, 70
 - conserving power 12–13
 - expected life 9
 - icons 11–12
 - installing 10
 - Low Battery option 12
 - model number 9, 76
 - power specifications 70, 76
 - safety 9
 - temperature 13
 - when to replace 11
- bin file. *See* firmware, upgrade information.

- black mark. *See* mark detection.
- Bluetooth
 - connecting to a scanner 33–34
 - device address (BDA) 33
 - finding current settings 58
 - maximum range 32
 - setting up communications 32–34
 - status icons 34
 - troubleshooting 61
- buttons. *See* Control Panel.

C

- calibrating the printer sensors 59
- cancel printing, with
 - ESC/P 4, 22
 - Fingerprint 4, 5, 22
 - IPL 4, 5, 22
- certificates. *See* 802.11 wireless, using certificates.
- cleaning
 - about 65–66
 - cleaning swab 66, 67, 77
 - exterior 67
 - identifying parts 66
 - label gap sensor 60
 - media compartment 68
 - platen roller 67
 - printhead 62, 66–67
- cold boot. *See* restarting the printer.
- communications ports. *See* connect printer to PC.
- connect printer to network
 - using 802.11 wireless 34–42
 - using Bluetooth 32–34
- connect printer to PC
 - using a serial connection 31–32
 - using USB 30–31
- Control Panel
 - backlight 12, 13
 - buttons 4
 - illustrated 3
 - layout 3–4
 - soft keys 5

D

- default password 37, 38, 40
- default settings. *See* factory default settings.
- differences between PB50 and PB51 3, 72
- display. *See* Control Panel.

- downloads 55
- Dump mode
 - about 24–25, 62–63
 - starting 24, 64
 - stopping 25, 64
 - white-on-black characters 63
- E**
- EasySet 33–34
- error
 - field out of label 60
 - icons 59–60
 - IP configuration 59
 - IP link 59
 - LSS too high 59
 - LSS too low 59
 - messages 58–60
 - network configuration 59
 - network connection 59
 - out of paper (Fingerprint) 59
 - paper out (IPL) 59
 - pause 59
 - printhead hot 59
 - printhead lifted 60
 - testfeed not done 59
 - upgrading 59
 - See also* troubleshooting.
- error messages 9
- Error mode 24
- Extended Test mode
 - about 25
 - functions 26
 - starting 25
 - stopping 25, 26
- F**
- factory default settings 25, 26
- fanfold media, load 17
- Feed button
 - functions 4
 - location 3
 - use as a soft key 5
- field out of label error 60
- Fingerprint setup menu 81
- firmware
 - current version 7, 58
 - upgrade information 47–55
 - upgrade warning 47
 - upgrading, with
 - HyperTerminal 51–55
 - PrintSet 47–49
- SmartSystems Foundation
 - 51
 - the printer home page 49–51
- fonts, downloading 55
- G**
- gap detection 71
- graphics, downloading 55
- H**
- HyperTerminal
 - about 31
 - settings 31, 44
 - troubleshooting 62
 - using to change settings 44
 - using to upgrade firmware 51–55
- I**
- identifying printer language 6
- images 55
- Info button
 - functions 4
 - location 3
 - use as a soft key 5, 22
- Information mode
 - about 21–22
 - starting 22
 - stopping 5, 22
- InterDriver software 30
- interfaces
 - about 74
 - RS-232 serial 74–75
 - USB 75–76
- IP address 45, 49
- IP configuration error 59
- IP link error 59
- IPL setup menu 80
- K**
- Knowledge Central 58
- L**
- label gap sensor 60
- languages
 - changing 8
 - described 7
- LED. *See* Ready-to-Work indicator, about.
- Line Analyzer 62–63
- See also* troubleshooting.
- LSS too high error 59

LSS too low error 59

M

mark detection 71–72

media

end of roll indicator 72

fanfold 14–16, 71, 72

jammed paper 9

label 71

label gap 60

loading 14–20

roll 14–16, 71

self-strip 19–20

sensitivity defaults 72

specifications 71–72

supported types 72–73

tag 71

media cover release button 3, 25

menu, menu system. *See* Control Panel.

N

network configuration error 59

network connection error 59

O

out of paper error 59

P

paper jam 9

paper out error 59

password 37, 38, 40

Pause mode

about 22

starting 4, 22

stopping 4, 22

platen roller

cleaning information 67

location 66

Power button. *See* Standby button.

power. *See* battery.

printer

calibrating the sensors 59

differences between PB50 and PB51 3, 72

find IP address 45, 49

intended uses 2

language 6

memory 70

operating temperatures 13, 70

password 37, 38, 40

platen roller 66

power specifications 70

print resolution 2, 70

printhead 66

printing speed 2, 70

quality 62, 72

sensor locations 66

serial number 58

size and weight 70

sounds 9

specifications 70–71

tear bar 66

printhead

cleaning information 66–67

location 66

printhead hot error 59

printhead lifted error 60

PrintSet 44, 47–49, 55, 62

product support. *See* support.

R

Ready mode 21

Ready-to-Work indicator

about 5–6

blinking 6, 60, 62

light off 5

light on 5

location 3

reference documents

ESC/P Programmer's Reference x

Fingerprint Command Reference x

Fingerprint Developer's Guide x, 7

IPL Command Reference x, 7

resetting the printer. *See* factory default settings.

restarting the printer 64

resume printing 22

S

safety information ix

Select Media function 26

self-strip. *See* media, self-strip.

serial connection

cable part number 31, 34, 47

connecting to a PC 31–32

finding current settings 58

illustrated 74–75

pins and descriptions 74–75

port communication settings

31, 31–32, 35

troubleshooting 62

See also connect printer to PC.

serial number 58

- settings
 - about 42–46
 - changing, with
 - the Control Panel 42–43
 - HyperTerminal 44
 - PrintSet 44
 - the printer home page 45–46
 - the SmartSystems console 46
 - Setup button
 - functions 4
 - location 3
 - use as a soft key 5, 14, 17
 - Setup mode
 - about 23–24
 - starting 4
 - stopping 4, 5
 - Sleep Timer
 - about 12
 - effect on Standby Timer 12
 - SmartSystems Foundation
 - download location 46, 51
 - using to change settings 46
 - using to upgrade firmware 51
 - soft keys 5
 - sounds 9
 - Standby button
 - functions 4
 - location 3
 - use as a soft key 5
 - Standby mode
 - about 13
 - starting 4, 13
 - stopping 13
 - Standby Timer 12–13
 - stop printing, with
 - ESC/P 4, 22
 - Fingerprint 4, 5, 22
 - IPL 4, 5, 22
 - support
 - information 58
 - Knowledge Central 58
 - phone number 58
 - website 58
- T**
- technical support. *See* support.
 - Test Labels function 26
 - Test mode. *See* Dump mode.
 - test page
 - about 26–27
 - information 58
 - printing, with
 - ESC/P 27
 - Fingerprint 27
 - IPL 26
 - troubleshooting 62
 - testfeed 4, 59
 - testfeed not done error 59
 - testprint. *See* test page.
 - troubleshooting
 - 802.11 wireless 61
 - about 60–63
 - battery 60, 61
 - Bluetooth 61
 - connection to PC 62
 - contrast 61, 62
 - label gap 60
 - power 60
 - print quality 61, 62, 72
 - serial connection 62
 - skipping labels 61
 - stop printing 60
 - test page 62
 - USB connection 62
 - using Dump mode 62–64
 - See also* error.
 - typefaces, downloading 55
- U**
- upgrade firmware. *See* firmware, upgrade information.
 - USB. *See* connecting printer to PC.
- W**
- warranty ix
 - wireless. *See* 802.11 wireless.



Worldwide Headquarters
6001 36th Avenue West
Everett, Washington 98203
U.S.A.

tel 425.348.2600

fax 425.355.9551

www.intermec.com

© 2012 Intermec Technologies
Corporation. All rights reserved.

PB50 and PB51 Mobile Printer User Guide



P/N 934-012-008