

WT41N0 WEARABLE TERMINAL INTEGRATOR GUIDE

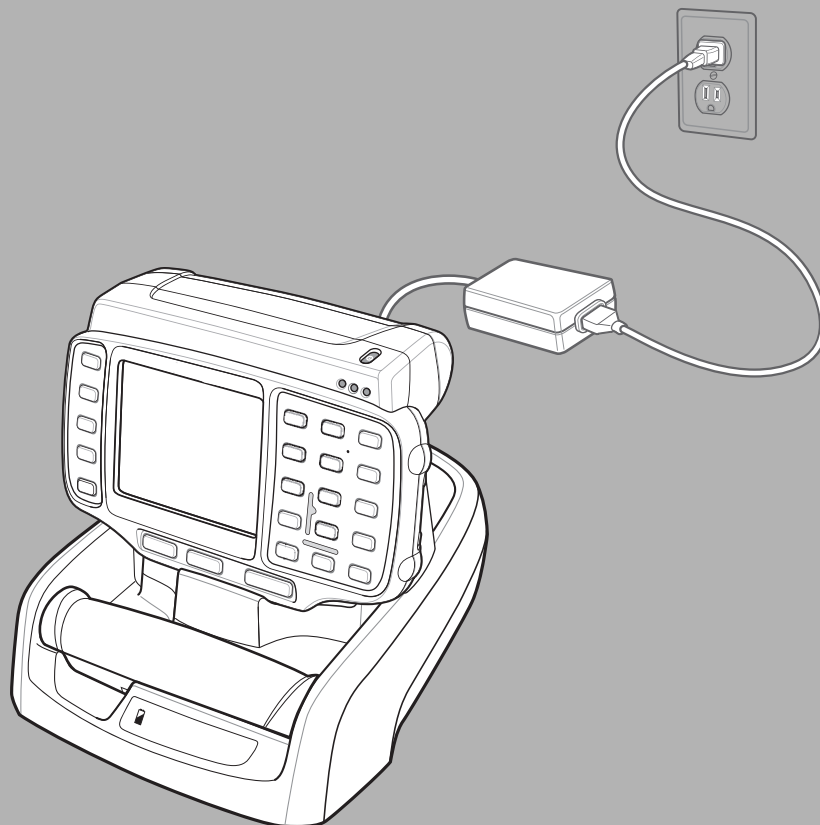

WT41N0
INTERGRATOR GUIDE

72E-160600-04

Rev. A

December 2016

No part of this publication may be reproduced or used in any form, or by any electrical or mechanical means, without permission in writing from Zebra. This includes electronic or mechanical means, such as photocopying, recording, or information storage and retrieval systems. The material in this manual is subject to change without notice.

The software is provided strictly on an “as is” basis. All software, including firmware, furnished to the user is on a licensed basis. Zebra grants to the user a non-transferable and non-exclusive license to use each software or firmware program delivered hereunder (licensed program). Except as noted below, such license may not be assigned, sublicensed, or otherwise transferred by the user without prior written consent of Zebra. No right to copy a licensed program in whole or in part is granted, except as permitted under copyright law. The user shall not modify, merge, or incorporate any form or portion of a licensed program with other program material, create a derivative work from a licensed program, or use a licensed program in a network without written permission from Zebra. The user agrees to maintain Zebra’s copyright notice on the licensed programs delivered hereunder, and to include the same on any authorized copies it makes, in whole or in part. The user agrees not to decompile, disassemble, decode, or reverse engineer any licensed program delivered to the user or any portion thereof.

Zebra reserves the right to make changes to any software or product to improve reliability, function, or design.

Zebra does not assume any product liability arising out of, or in connection with, the application or use of any product, circuit, or application described herein.

No license is granted, either expressly or by implication, estoppel, or otherwise under any Zebra Technologies Corporation, intellectual property rights. An implied license only exists for equipment, circuits, and subsystems contained in Zebra products.

Revision History

Changes to the original manual are listed below:

Change	Date	Description
-01 Rev. A	12/01/2012	Initial release.
-02 Rev. A	12/11/2014	Zebra rebranding
-02 Rev. B	03/2015	Zebra rebranding
-02 Rev. C	05/2016	Remove references to Device Configuration Package, which is not supported in CE 7.0.
-03 Rev. A	11/2016	Add support for RS5000.
-04 Rev. A	12/2016	Provide special instructions for RS5000.

TABLE OF CONTENTS

Revision History	iii
------------------------	-----

About This Guide

Introduction	xi
Documentation Set	xi
Configurations	xii
Software Versions	xii
Chapter Descriptions	xiii
Notational Conventions	xiii
Related Documents and Software	xiv
Service Information	xv

Chapter 1: Getting Started

Introduction	1-1
Unpacking the Wearable Terminal	1-1
Features	1-1
Getting Started	1-3
Installing and Removing the Main Battery	1-3
Installing the Main Battery	1-3
Charging the Battery	1-4
Charging the Main Battery and Backup Battery	1-4
Charging Spare Batteries	1-5
Removing the Main Battery	1-5
Starting the Wearable Terminal	1-6
WT41N0 Boot Up	1-6
Voice Only WT41N0 Boot Up	1-6
Checking Battery Status	1-7
Configuring the Wearable Terminal	1-8
Resetting the Wearable Terminal	1-8
Performing a Warm Boot	1-8
Performing a Cold Boot	1-8
Battery Management	1-8
Battery Saving Tips	1-8

Changing the Power Settings	1-9
Changing the Display Backlight Settings	1-9
Changing the Keypad Backlight Settings	1-9
Turning the WLAN Radios Off	1-10
Long Term Storage	1-10

Chapter 2: Accessories

Introduction	2-1
Single Slot USB Cradle	2-3
Battery Charging Indicators	2-4
Communication Setup	2-5
Four Slot Ethernet Cradle	2-6
CRD4000-4000ER Setup	2-6
Daisy chaining CRD4000-4000ER Cradles	2-7
LED Indicators (CRD4000-4000ER)	2-8
CRD4001-4000ER Setup	2-8
Daisy-chaining CRD4001-4000ER Cradles	2-9
LED Indicators (CRD4001-4000ER)	2-10
Ethernet Cradle Drivers	2-10
Charging and Communication	2-12
Battery Charging Indicators	2-12
Four Slot Spare Battery Charger	2-13
Spare Battery Charging	2-13
Battery Charging Indicators	2-14
Wall Mount Bracket	2-15
Power Supply Installation	2-16
Four Slot Ethernet Cradle Installation	2-17
Four Slot Battery Charger Installation	2-19
Wiring	2-19
Placing a Battery in the Charger	2-21
Mounting Multiple Brackets	2-21
Navigating the Wearable Terminal with an External Input Device	2-23
USB Device	2-23
Connector Shroud	2-25
Assembly	2-25
Disconnecting the Cable from the Wearable Terminal	2-25

Chapter 3: Synchronization

Introduction	3-1
Installing the Sync Software	3-1
WT41N0 Setup	3-1
Setting Up a Sync Connection	3-2
ActiveSync (Windows XP)	3-2
Windows Mobile Device Center (Windows 7)	3-3
Setting up a Partnership	3-4

Chapter 4: Voice Only WT41N0 Remote Control

Introduction	4-1
--------------------	-----

MotoRC Software	4-1
Microsoft ActiveSync Remote Display Software	4-1
Connection to Host Computer	4-1
MotoRC Connection	4-2
Microsoft ActiveSync Remote Display Connection	4-3

Chapter 5: Wireless Applications

Introduction	5-1
Signal Strength Icon	5-2
Turning the Radio On and Off	5-3
On a WT41N0 with Touch Screen	5-3
On a WT41N0 with Non-touch Screen	5-3
Minimum Setup	5-4

Chapter 6: Bluetooth

Introduction	6-1
Adaptive Frequency Hopping	6-1
Security	6-2
Security Mode 3 (Link Level Encryption)	6-2
Microsoft Bluetooth Stack	6-2
StoneStreet One Bluetooth Stack	6-2
FIPS 140-2	6-3
Bluetooth Configuration	6-3
Bluetooth Power States	6-4
Cold Boot	6-4
Warm Boot	6-4
Suspend	6-4
Resume	6-4
MotoBTUI Application	6-4
Device Information	6-5
FIPS Configuration	6-5
Device Status	6-6
Using the StoneStreet One Bluetooth Stack	6-7
Turning the Bluetooth Radio Mode On and Off	6-7
Disabling Bluetooth	6-7
Enabling Bluetooth	6-7
Using App Launcher	6-8
Using Key Combination	6-8
Using Screen Touch	6-8
BTE Explorer Non-touch Display Navigation	6-8
Key Combinations	6-8
Discovering Bluetooth Device(s)	6-9
Available Services	6-12
File Transfer Services	6-12
Connect to Internet Using Access Point	6-15
OBEX Object Push Services	6-16
Headset Services	6-17
Serial Port Services	6-17
Personal Area Network Services	6-18

HID Services	6-18
Bonding with Discovered Device(s)	6-18
Connecting to a Favorite Service	6-21
Delete all Favorite Services	6-22
Delete a Favorite Service	6-22
Rename a Favorite Service	6-22
Change the Display View	6-23
View Active Connections	6-23
View Properties	6-23
Bluetooth Settings	6-23
Device Info Tab	6-23
Services Tab	6-24
Security	6-27
Discovery Tab	6-27
Virtual COM Port Tab	6-28
HID Tab	6-28
Profiles	6-29
System Parameters	6-29
Miscellaneous Tab	6-29
Using the Microsoft Bluetooth Stack	6-30
Power Modes	6-30
Turning the Bluetooth Radio Mode On and Off	6-30
Disabling Bluetooth	6-30
Enabling Bluetooth	6-30
Discovering Bluetooth Device(s)	6-31
Available Services	6-32
Bluetooth Printing	6-33
Headset Services	6-34

Chapter 7: Application Development

Introduction	7-1
Software Installation on Development PC	7-1
Platform SDK	7-1
EMDK for C	7-2
Installing Other Development Software	7-2
Software Updates	7-2
Windows CE Flash Storage	7-2
FFS Partitions	7-3
Working with FFS Partitions	7-3
RegMerge.dll	7-3
CopyFiles	7-4
Non-FFS Partitions	7-4
Downloading Partitions to the WT41N0	7-4
Bootloader	7-4
Partition Update vs. File Update	7-5
Upgrade Requirements	7-5
Deployment	7-5
Copying Files from a Host Computer	7-5
ActiveSync	7-5
Mass Storage	7-7

Updating Images	7-8
OSUpdate Loader	7-8
Bootloader	7-9
Bootloader Error Detection	7-13
Mobility Services Platform	7-15
Creating a Splash Screen	7-15

Chapter 8: Special Considerations

Introduction	8-1
Touch Panel User Interface Considerations	8-1
Tips for Improving Battery Life	8-1
Display Backlight	8-1
Keypad Light	8-2
Power	8-2
Wireless LAN	8-3
Voice Only WT41N0 LED Considerations	8-3
RS5000 Low Charge Considerations	8-3

Chapter 9: Maintenance & Troubleshooting

Introduction	9-1
Maintaining the Wearable Terminal	9-1
Wrist Mount Cleaning Instructions	9-2
Arm Sleeve Cleaning Instructions	9-2
Removing the Screen Protector	9-2
Battery Safety Guidelines	9-3
Cleaning	9-4
Materials Required	9-4
Cleaning the Wearable Terminal	9-4
Housing	9-4
Display	9-4
Connectors	9-4
Cleaning the RS309, RS409, RS419, RS507 and RS5000	9-5
Housing	9-5
Scanner Exit Window	9-5
Connectors	9-5
Cleaning Cradle Connectors	9-5
Cleaning Frequency	9-6
Troubleshooting	9-6
Wearable Terminal	9-6
Four Slot Spare Battery Charger	9-10
Four Slot Ethernet Cradle	9-10
Single Slot USB Cradle	9-11

Appendix A: Technical Specifications

Technical Specifications	A-1
Wearable Terminal	A-1
RS309 Scanner	A-3
RS409 Scanner	A-4

RS419 Scanner	A-5
RS507 Scanner	A-6
RS5000 Scanner	A-8
Accessories	A-9
Decode Zones	A-13
RS309	A-13
RS409	A-16
RS419	A-19

Appendix B: Software Setup

Bluetooth Configuration Setting	B-1
---------------------------------------	-----

Glossary

Index

ABOUT THIS GUIDE

Introduction

This guide provides information about using the WT41N0 family of mobile terminals and accessories. The WT41N0 has three versions:

- Touch display
- Non-touch display
- Voice-only version without a display.

Throughout this guide Voice Only WT41N0 refers to the version without the display and WT41N0 refers to the version with a display. Wearable terminal refers to all versions.

✓ **NOTE** Screens and windows pictured in this guide are samples and can differ from actual screens.

Documentation Set

The documentation set for the WT41N0 is divided into guides that provide information for specific user needs.

- **WT41N0 Quick Start Guide** - provides information for using the WT41N0 wearable terminal.
- **Voice Only WT41N0 Quick Start Guide** - provides information for using the Voice Only WT41N0 wearable terminal.
- **WT41N0 User Guide** - describes how to operate the wearable terminal.
- **WT41N0 Integrator Guide** - describes how to set up the wearable terminal and the accessories.
- **EMDK Help File** - provides API information for writing applications.

Configurations

This guide covers the following configurations:

Configuration	Radios	Display	Memory	Data Capture	Operating System	Keypads
WT41N0	WLAN: 802.11a/b/g/n WPAN: Bluetooth	2.8" QVGA Color; non-touch	2 GB Flash/ 512 MB RAM	Optional accessory	Windows CE 7.0 Professional	Alphanumeric Keypad
		2.8" QVGA Color; touch	2 GB Flash/ 512 MB RAM	Optional accessory	Windows CE 7.0 Professional	Alphanumeric Keypad
Voice Only WT41N0	WLAN: 802.11a/b/g/n WPAN: Bluetooth	None	2 GB Flash/ 512 MB RAM	Optional accessory	Windows CE 7.0 Professional	Three keys

Software Versions

- ✓ **NOTE** To view the software versions on the Voice Only WT41N0, the Voice Only WT41N0 must be connected to a host computer running remote desktop software. See [Chapter 4, Voice Only WT41N0 Remote Control](#) for more information.

This guide covers various software configurations and references are made to operating system or software versions for:

- OEM version
- Fusion version.

OEM Software

To determine the OEM software version:

1. Press **CTRL** and then **ESC** to open the **Start** menu.
2. Using the navigation keys, select **Settings**.
3. Press the Blue key and the down arrow to open the **Control Panel** sub-menu.
4. Press **ENTER** key to launch **Control Panel**.
5. Using the navigation keys, select the **System Information** icon.
6. Press **ENTER** key to launch **System Information** applet.

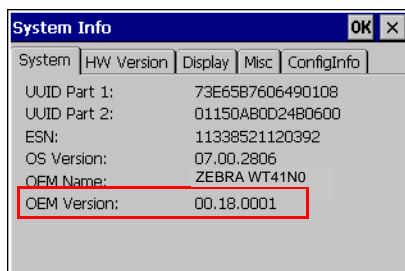

Fusion Software

To determine the Fusion software version:

1. Press **ALT - w**. The **Wireless** menu appears.
2. Using the navigation keys, select **Wireless Status**.
3. Press **ENTER**. The **Wireless Status** window displays.
4. Press **6**. The **Versions** screen appears.

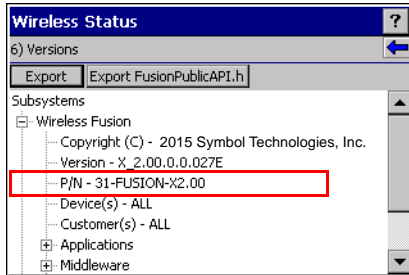

Chapter Descriptions

Topics covered in this guide are as follows:

- [Chapter 1, Getting Started](#), lists the accessories for the wearable terminal and explains how to install and charge the batteries and start the wearable terminal for the first time.
- [Chapter 2, Accessories](#), describes the accessories available for the wearable terminal.
- [Chapter 3, Synchronization](#), provides instructions on installing ActiveSync and setting up a partnership between the wearable terminal and a host computer.
- [Chapter 4, Voice Only WT41N0 Remote Control](#), provides instructions for using remote control software with the Voice Only WT41N0.
- [Chapter 5, Wireless Applications](#), provides instructions on using and configuring the wearable terminal on a wireless network.
- [Chapter 6, Bluetooth](#), explains Bluetooth functionality on the wearable terminal.
- [Chapter 7, Application Development](#), describes features in Windows CE 7.0 including how to package applications, and procedures for deploying applications onto the wearable terminal.
- [Chapter 8, Special Considerations](#), provides special instructions for the wearable terminal.
- [Chapter 9, Maintenance & Troubleshooting](#), includes instructions on cleaning and storing the wearable terminal, and provides troubleshooting solutions for potential problems during wearable terminal operation.
- [Appendix A, Technical Specifications](#), includes a table listing the technical specifications for the wearable terminal and accessories.

Notational Conventions

The following conventions are used in this document:

- “Wearable terminal” refers to the WT41N0 series of wearable terminals.

- *Italics* are used to highlight the following:
 - Chapters and sections in this guide
 - Related documents
- **Bold** text is used to highlight the following:
 - Dialog box, window and screen names
 - Drop-down list and list box names
 - Check box and radio button names
 - Icons on a screen
 - Key names on a keypad
 - Button names on a screen.
- Bullets (•) indicate:
 - Action items
 - Lists of alternatives
 - Lists of required steps that are not necessarily sequential.
- Sequential lists (e.g., those that describe step-by-step procedures) appear as numbered lists.
- Key sequences. When multiple key presses are required, follow the following
 - Key - key: Press and release the first key and then press and release the second key.

Related Documents and Software

The following documents provide more information about the WT41N0 wearable terminals.

- *WT41N0 Quick Start Guide*, p/n 72-157178-xx
- *Voice Only WT41N0 Quick Start Guide*, p/n 72-162043-xx
- *WT41N0 Regulatory Guide*, p/n 72-159559-xx
- *WT41N0 User Guide*, p/n 72E-159561-xx
- *RS309 Scanner Quick Reference Guide*, p/n 72-86011-xx
- *RS409 Scanner Quick Reference Guide*, p/n 72-86010-xx
- *RS419 Scanner Quick Reference Guide*, p/n 72-158357-xx
- *RS507 Hands-free Imager Quick Reference Guide*, p/n 72-115987-xx
- *RS507 Hands-free Imager Product Reference Guide*, p/n 72E-120802-xx
- *RS5000 Scanner Quick Reference Guide*, p/n MN-002933-xx
- *Wireless Fusion Enterprise Mobility Suite User Guide for Version 2.XX*, p/n 72E-xxxxxx-xx
- *Enterprise Mobility Developer Kits*, available at: <http://www.zebra.com/support>.
- Platform SDK (PSDK41N0c70) for WT41N0 with Windows CE 7.0, available at: <http://www.zebra.com/support>.
- ActiveSync software, available at: <http://www.microsoft.com>.

For the latest version of this guide and all guides, go to: <http://www.zebra.com/support>.

Service Information

If you have a problem with your equipment, contact Zebra Global Customer Support for your region. Contact information is available at: <http://www.zebra.com/support>.

When contacting Zebra Global Customer Support, please have the following information available:

- Serial number of the unit
- Model number or product name
- Software type and version number

Zebra responds to calls by email, telephone or fax within the time limits set forth in support agreements.

If your problem cannot be solved by Zebra Global Customer Support, you may need to return the equipment for servicing and will be given specific directions. Zebra is not responsible for any damages incurred during shipment if the approved shipping container is not used. Shipping the units improperly can possibly void the warranty.

If you purchased your Zebra business product from a Zebra business partner, contact that business partner for support.

CHAPTER 1 GETTING STARTED

Introduction

This chapter lists the accessories for the wearable terminal and explains how to install and charge the batteries and start the wearable terminal for the first time.

Unpacking the Wearable Terminal

Carefully remove all protective material from around the wearable terminal and save the shipping container for later storage and shipping.

Verify that you received all equipment listed below:

- Wearable terminal
- Lithium-ion battery
- Regulatory Guide
- Quick Start Guide.

Inspect the equipment for damage. If you are missing any equipment or if you find any damaged equipment, contact Zebra Global Customer Support immediately. See [Service Information on page xv](#) for contact information.

Features

Figure [Figure 1-1](#) and [Figure 1-2](#) indicate the features of the WT41N0 and Voice Only WT41N0 wearable terminals.

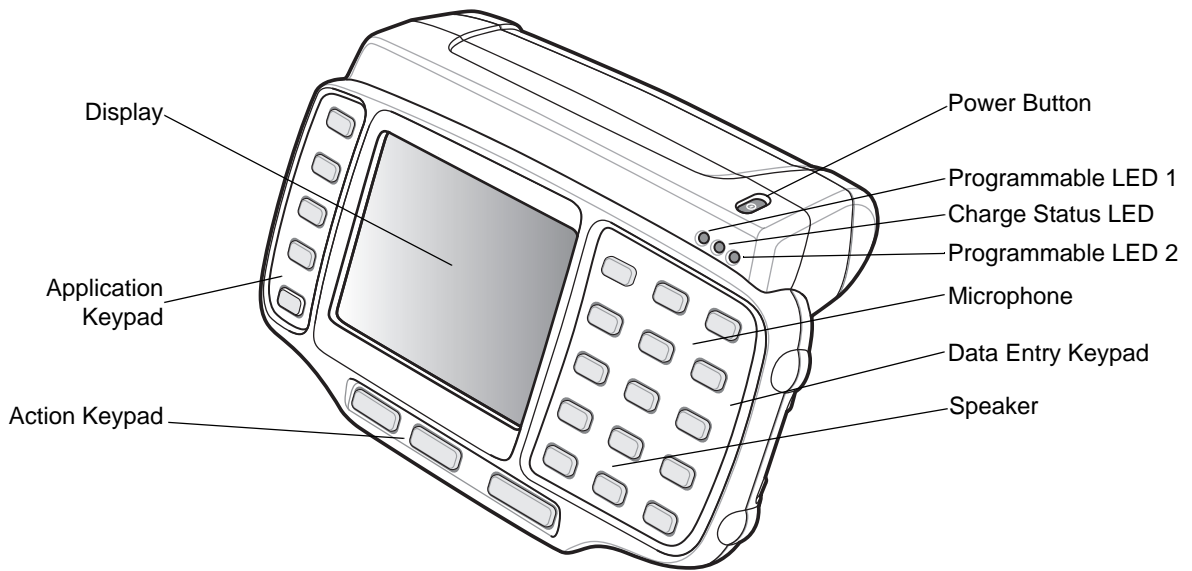

Figure 1-1 WT41N0 Wearable Terminal Front View

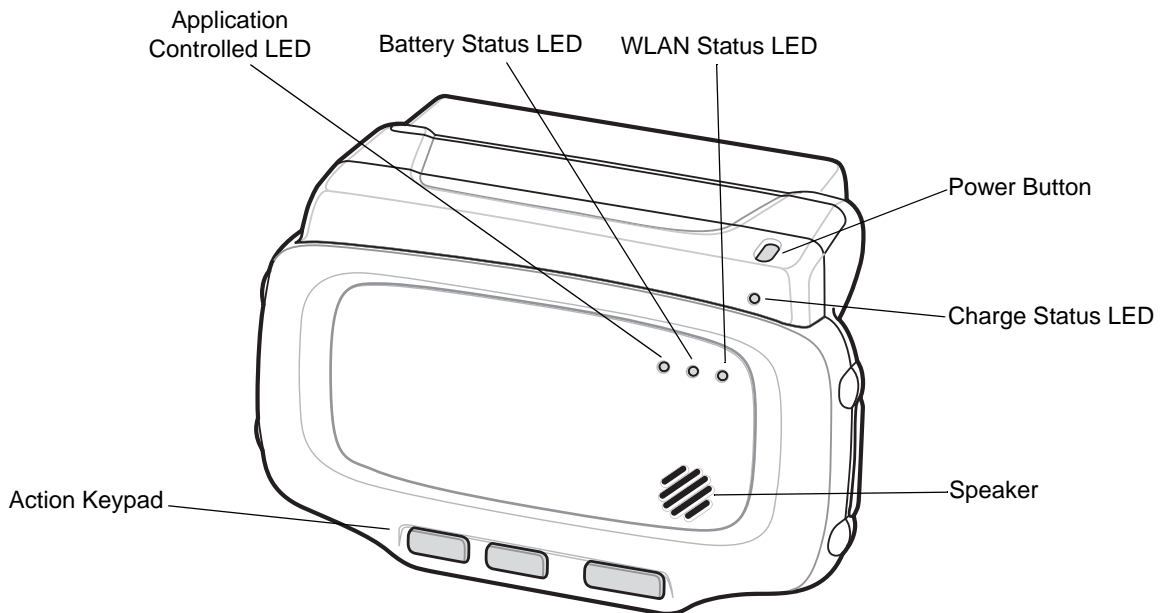

Figure 1-2 Voice Only WT41N0 Wearable Terminal Front View

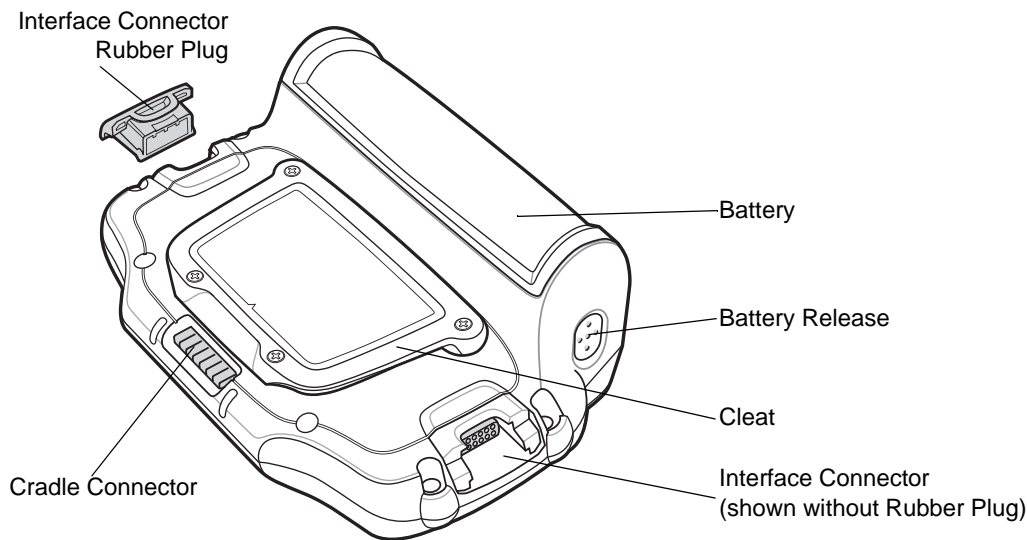

Figure 1-3 Wearable Terminal Back View

Getting Started

In order to start using the wearable terminal for the first time:

- Install the main battery
- Charge the main battery and backup battery
- Start the wearable terminal.

✓ **NOTE** The main battery can be charged before or after installation into the wearable terminal. Use the Single Slot USB cradle or Four Slot Spare Battery Charger to charge the main battery before installation, or the Single Slot USB cradle or Four Slot Ethernet cradle to charge the main battery after installation.

Installing and Removing the Main Battery

Installing the Main Battery

Before using the wearable terminal, install a lithium-ion battery by placing the battery into the wearable terminal as shown in [Figure 1-4](#).

✓ **NOTE** Ensure the battery is fully inserted. An audible click can be heard as the battery is fully inserted. A partially inserted battery may result in unintentional data loss.

When a battery is fully inserted in a wearable terminal for the first time, upon the wearable terminal's first power up, the device boots and powers on automatically.

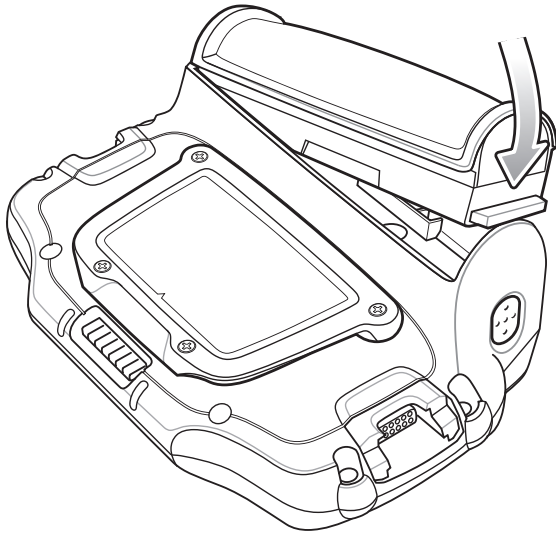

Figure 1-4 Installing the Main Battery

Charging the Battery



CAUTION Ensure that you follow the guidelines for battery safety described in *Battery Safety Guidelines* on page 9-3.

Charging the Main Battery and Backup Battery

Before using the wearable terminal for the first time, charge the main battery until the amber Charge Status LED remains lit (see [Table 1-1 on page 1-5](#) for charge status indications).

The wearable terminal is equipped with a backup battery which automatically charges from the main battery whether or not the wearable terminal is operating or is in suspend mode. The backup battery retains data in memory for at least 15 minutes when the wearable terminal's main battery is removed or fully discharged. When the wearable terminal is used for the first time or after the backup battery has fully discharged, the backup battery requires approximately 15 hours to fully charge. Do not remove the main battery from the wearable terminal for 16 hours to ensure that the backup battery fully charges. If the main battery is removed from the wearable terminal or the main battery is fully discharged, the memory backup battery completely discharges in several hours.

When the wearable terminal reaches a very low battery state, the combination of main battery and backup battery retains data in memory for at least 24 hours.



NOTE Do not remove the main battery within the first 15 hours of use. If the main battery is removed before the backup battery is fully charged, data may be lost.

Charge the wearable terminal with an installed main battery using either the Single Slot USB cradle or the Four Slot Ethernet cradle.

To charge the main battery:

1. Ensure the cradle used to charge the main battery is connected to the appropriate power source.
2. Insert the wearable terminal into a cradle.

- The wearable terminal starts to charge automatically. The amber Charge Status LED lights to indicate the charge status. See [Table 1-1](#) for charging indications.

Table 1-1 *Wearable Terminal LED Charge Indicators*

LED	Indication
Off	Wearable terminal is not in cradle. Wearable terminal not placed correctly. Charger is not powered.
Fast Blinking Amber	Charging error: <ul style="list-style-type: none"> Temperature is too low or too high. Charging has gone on too long without completing (typically eight hours).
Slow Blinking Amber	Wearable terminal is charging.
Solid Amber	Charging complete. Note: When the battery is initially inserted in the wearable terminal, the amber LED flashes once if the battery power is low or the battery is not fully inserted.

Charging Spare Batteries

Use the following accessories to charge spare batteries:

- Single Slot USB cradle
- Four Slot Spare Battery charger.

To charge a spare battery:

- Ensure the accessory used to charge the spare battery is connected to the appropriate power source.
- Insert the spare battery into the accessory's spare battery charging slot with the charging contacts facing down (over the charging pins) and gently press down on the battery to ensure proper contact.
- The battery starts to charge automatically. The amber charge LED on the accessory lights to show the charge status. See [Chapter 2, Accessories](#) for accessory charge LED indicator definitions.

Removing the Main Battery

To remove the main battery:

- Prior to removing the battery, ensure that the wearable terminal is in suspend mode. If the wearable terminal is not in suspend mode, press the Power button to place the wearable terminal in suspend mode.
- Press the battery release button. The battery partially ejects from the wearable terminal.
- Remove the battery from the wearable terminal.

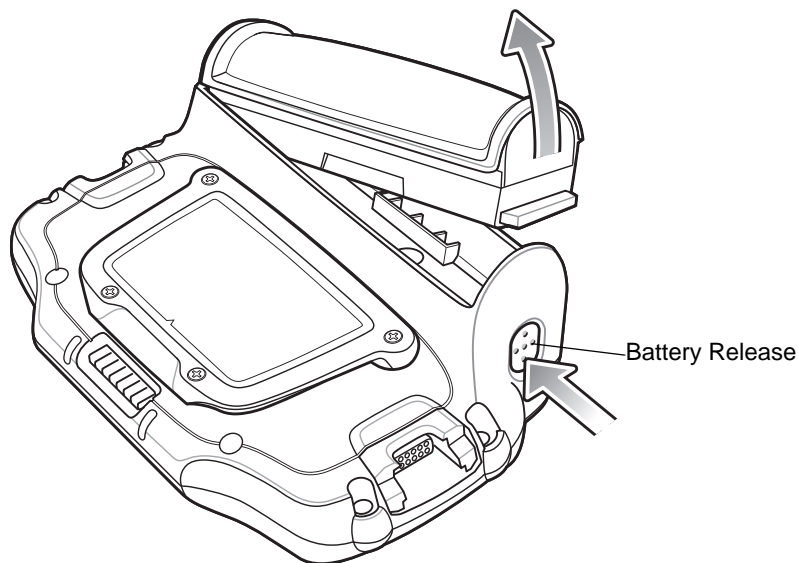

Figure 1-5 Removing the Main Battery

Starting the Wearable Terminal

Press the **Power** button to turn on the wearable terminal. If the wearable terminal does not power on, perform a cold boot. See [Performing a Cold Boot on page 1-8](#).

- ✓ **NOTE** When a battery is fully inserted in a wearable terminal for the first time, upon the wearable terminal's first power up, the device boots and powers on automatically.

WT41N0 Boot Up

When the WT41N0 is powered on for the first time the splash screen appears for a short period of time followed by the Start Up window on non-touch configurations and the calibration screen on touch enabled configurations.

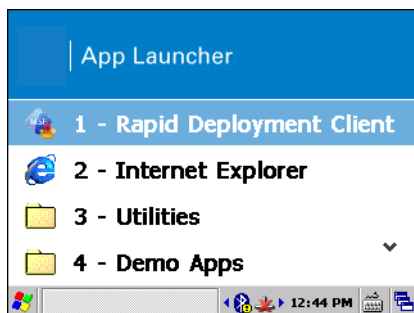

Figure 1-6 Start Up Window App Launcher

Voice Only WT41N0 Boot Up

When the Voice Only WT41N0 is powered on the three LEDs on the front housing light in the sequence shown in [Table 1-2](#).

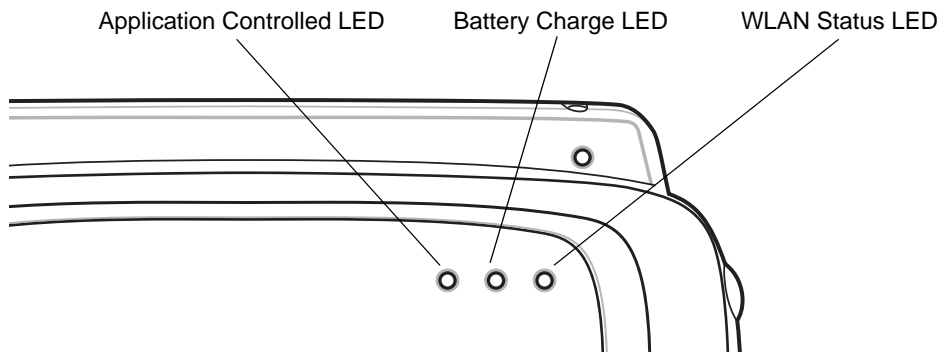

Figure 1-7 Voice Only WT41N0 LEDs

Table 1-2 Voice Only WT41N0 Start Up LED Sequence

Sequence	Application Controlled LED	Battery Charge LED	WLAN Status LED
1	On	On	On
2	On	On	Off
3	Off	Off	Off
4	On	Off	Off
5	On	On	Off
6	On	On	On
7	On	On	Off
8	On	Off	Off
9	Off	Off	Off
10	Off	Off	On/Blinking

The WLAN Status LED blinks indicating that the wireless connection is not connected or is solid indicating that the wireless connection is connected.

Checking Battery Status

✓ **NOTE** To navigate using the keypad refer to the *WT41N0 Wearable Terminal User Guide*.

To check whether the main battery or backup battery in the wearable terminal is charged:

1. Select **Start > Settings > Control Panel > Power** icon to display the **Battery Status** window.
2. Press **ENTER**.

To save battery power, set the wearable terminal to turn off after a specified number of minutes.

Configuring the Wearable Terminal

- To set up ActiveSync to synchronize the wearable terminal with the host computer, see [Chapter 3, Synchronization](#).
- To configure the wearable terminal for wireless LAN network, see [Chapter 5, Wireless Applications](#).
- To deploy software on the wearable terminal, see [Chapter 7, Application Development](#).

Resetting the Wearable Terminal

There are two reset functions, warm boot and cold boot. A warm boot restarts the wearable terminal by closing all running programs.

A cold boot also restarts the wearable terminal, but erases all stored records and entries in RAM. Data saved in flash memory is not lost. In addition it returns formats, preferences and other settings to the factory default settings.

Perform a warm boot first. This restarts the wearable terminal and saves all *stored* records and entries. If the wearable terminal still does not respond, perform a cold boot.

Performing a Warm Boot

Hold down the Power button for approximately five seconds. As soon as the wearable terminal starts to perform a warm boot release the Power button.

Performing a Cold Boot

A cold boot restarts the wearable terminal and erases all user stored records and entries that are not saved in flash memory (Application and Platform folders). *Never perform a cold boot unless a warm boot does not solve the problem.*

✓ **NOTE** Any data previously synchronized with a computer can be restored during the next ActiveSync operation.

To perform a cold boot on a WT41N0 press and simultaneously hold the Power button and the **1** and **9** keys. Do not hold down any other keys or buttons. The wearable terminal initializes.

To perform a cold boot on a Voice Only WT41N0 press and simultaneously hold the **P1** and **P2 keys**, and the Power button. The Voice Only WT41N0 initializes.

Battery Management

Battery Saving Tips

- Place the wearable terminal in a cradle connected to AC power at all times when not in use.
- Set the wearable terminal to turn off after a short period of non-use.
- Set the display and keypad backlight to turn off after a short period of non-use.
- Turn on the keypad backlight only if needed.

- Turn off all wireless radio activity when not in use.

Changing the Power Settings

✓ **NOTE** To navigate using the keypad refer to the *WT41N0 User Guide*.

To set the wearable terminal to turn off after a short period of non-use:

1. Select **Start > Settings > Control Panel > Power icon > Advanced** tab.
2. Press **ENTER**.
3. Select the **On battery power: Turn off device if not used for:** check box and select a value from the drop-down list box.
4. Press **ENTER**.

Changing the Display Backlight Settings

✓ **NOTE** To navigate using the keypad refer to the *WT41N0 User Guide*.
Not applicable on the Voice Only WT41N0.

Changing the Backlight setting on the Voice Only WT41N0 will change the brightness of the Application Controlled LED. Refer to the EMDK Help file WT41N0-VOW Programming page for more information.

To change the display backlight settings in order to conserve more battery power:

1. Select **Start > Settings > Control Panel > Backlight icon > Battery Power** tab.
2. Press **ENTER**.
3. Select the **On battery power: Disable backlight if not used for:** check box and select a value from the drop-down list box.
4. Select the **Brightness** tab.
5. Select the **Disable backlight** check box to completely turn off the display backlight.
6. Use the slider to set the brightness of the backlight. Set it to a low value to save battery power.
7. Press **ENTER**.

Changing the Keypad Backlight Settings

✓ **NOTE** To navigate using the keypad refer to the *WT41N0 User Guide*.
Not applicable on the Voice Only WT41N0.

Changing the Keypad Backlight setting on the Voice Only WT41N0 will change the brightness of the WLAN Status LED. Refer to the EMDK Help file WT41N0-VOW Programming page for more information.

To change the keypad backlight settings in order to conserve more battery power:

1. Select **Start > Settings > Control Panel > Keylight icon > Battery Power** tab.
2. Press **ENTER**.

3. Select the **On battery power: Disable keylight if not used for:** check box and select a value from the drop-down list box.
4. Select the **Advanced** tab.
5. Select the **Disable keylight** check box to completely turn off the keypad backlight.
6. Press **ENTER**.

Turning the WLAN Radios Off

✓ **NOTE** To navigate using the keypad refer to the *WT41N0 User Guide*.

To turn off the WLAN radio:

1. Press **ALT - w**. The Wireless menu appears.
2. Select **Disable Radio**.
3. Press **ENTER**.

To turn on the radio:

1. Press **ALT - w**. The Wireless menu appears.
2. Select **Enable Radio**.
3. Press **ENTER**.

Long Term Storage

When storing the wearable terminal for a long period of time it is recommended to place the wearable terminal in storage mode.

1. Remove the main battery.
2. On the WT41N0, press and simultaneously hold the **1, 9** keys and Power button (cold boot).

or

On the Voice Only WT41N0, press and simultaneously hold the **P1** and **P2** keys and the Power button (cold boot).

3. Release the keys and Power button.

When returning the wearable terminal to everyday operation, install a fully charged main battery.

CHAPTER 2 ACCESSORIES

Introduction

Wearable terminal accessories provide a wide variety of product support capabilities. Accessories include cradles, a battery charger, scanners and headsets. Table 2-1 lists the accessories available for the WT41N0.

Table 2-1 *Wearable Terminal Accessories*

Accessory	Description
Single Slot USB Cradle	Charges the wearable terminal main battery and a spare battery. It also synchronizes the wearable terminal with a host computer through a USB connection.
Four Slot Ethernet Cradle	Charges up to four wearable terminals (with main battery installed) and provides communication through an Ethernet connection.
Four Slot Spare Battery Charger	Charges up to four spare batteries.
RS409 Scanner	Provides 1D scanning capability.
RS419 Scanner	Provides 1D scanning capability.
RS309 Scanner	Provides 1D scanning capability.
RS507 Scanner	Provides wired or wireless imaging capability.
RS5000 Scanner	Provides wired imaging capability.
Wrist Mount	Provides a means for wearing the wearable terminal on the arm for hands-free applications.
Hip Mount	Provides a means for wearing the wearable terminal on a belt for hands-free applications.
Headset	For audio playback/recording during voice-enabled applications.
Headset Adapters	Connect an optional headset to the wearable terminal.

Table 2-1 *Wearable Terminal Accessories (Continued)*

Accessory	Description
Replacement Batteries	Standard Capacity Battery: 2330 mAh (minimum) Extended Capacity Battery: 4600 mAh (minimum)
Standard Capacity Battery Freezer Pouch	Allows the user to use the wearable terminal with standard capacity battery in a freezer environment on the hip or wrist for use in voice picking applications.
Extended Capacity Battery Freezer Pouch	Allows the user to use the wearable terminal with extended capacity battery in a freezer environment on the hip or wrist for use in voice picking applications.
USB Adapter	Connects the Single-slot cradle to USB hubs, mice, keyboards and memory. The adapter has a USB mini-A connector on the cradle side and a USB A Female connector on the other side.
Connector Shroud	Protects the connector of an accessory that connects to the wearable computer.
Screen Protectors	Package of 3 screen protectors.
Arm Sleeve	Extra layer sleeve to wear under wrist mount for extra comfort and hygiene.
RCH51 Rugged Cabled Headset	Enables hands-free voice-directed mobility communication. An audible mono headset with noise cancelling boom microphone helps survive harsh environments.

Single Slot USB Cradle



CAUTION Ensure that you follow the guidelines for battery safety described in *Battery Safety Guidelines* on page 9-3.

This section describes how to set up and use a Single Slot USB cradle with the wearable terminal. For USB communication setup procedures see *Communication Setup* on page 2-5.

The Single Slot USB cradle:

- Provides 5.4 VDC power for operating the wearable terminal.
- Provides USB ports for data communication between the wearable terminal and a host computer or other serial devices (e.g., a printer).

✓ **NOTE** The normal function of the product may be disturbed by Strong Electro Magnetic Interference (for example, static electricity). If so, simply remove and re-insert the terminal to resume normal operation. In case the function does not resume, please use the product in another location.

- Synchronizes information between the wearable terminal and a host computer. (With customized or third party software, it can also be used to synchronize the wearable terminal with corporate databases.)
- Charges the wearable terminal's battery.
- Charges a spare battery.
- Provides a location for storing an attached scanner during charging.

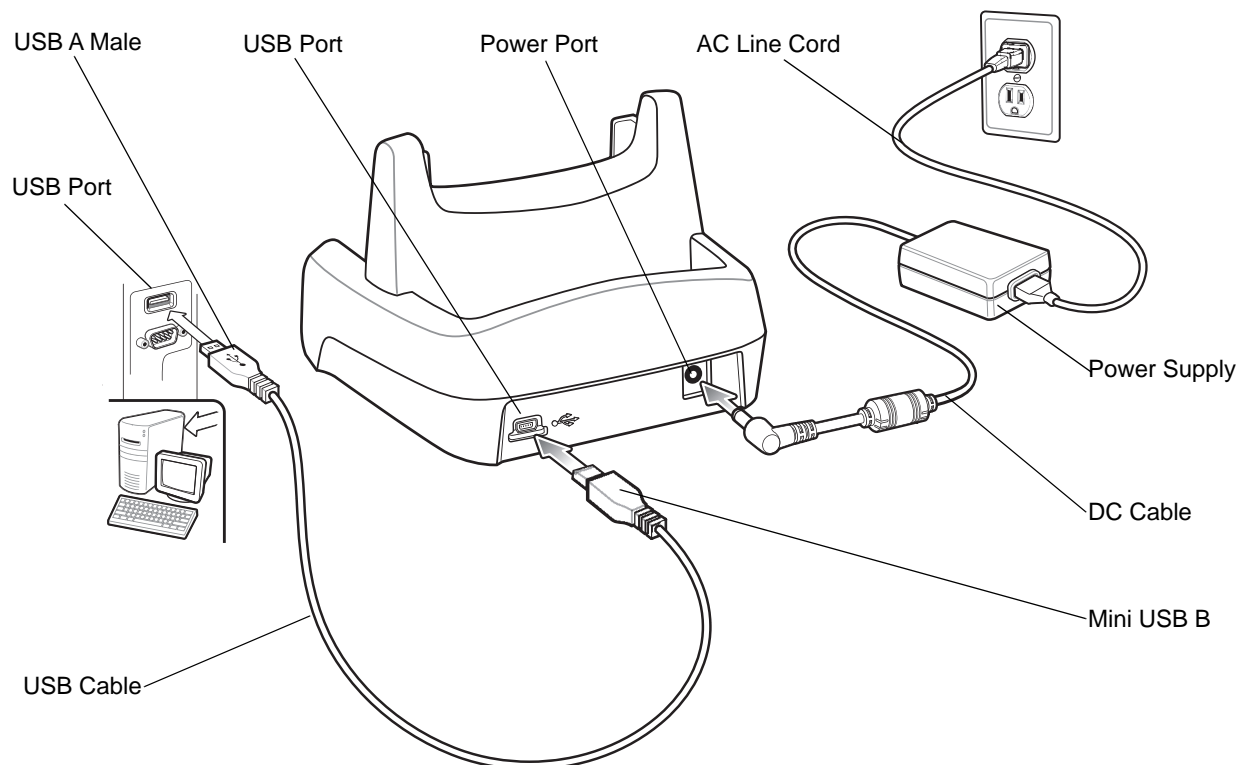

Figure 2-1 Single Slot USB Cradle Setup

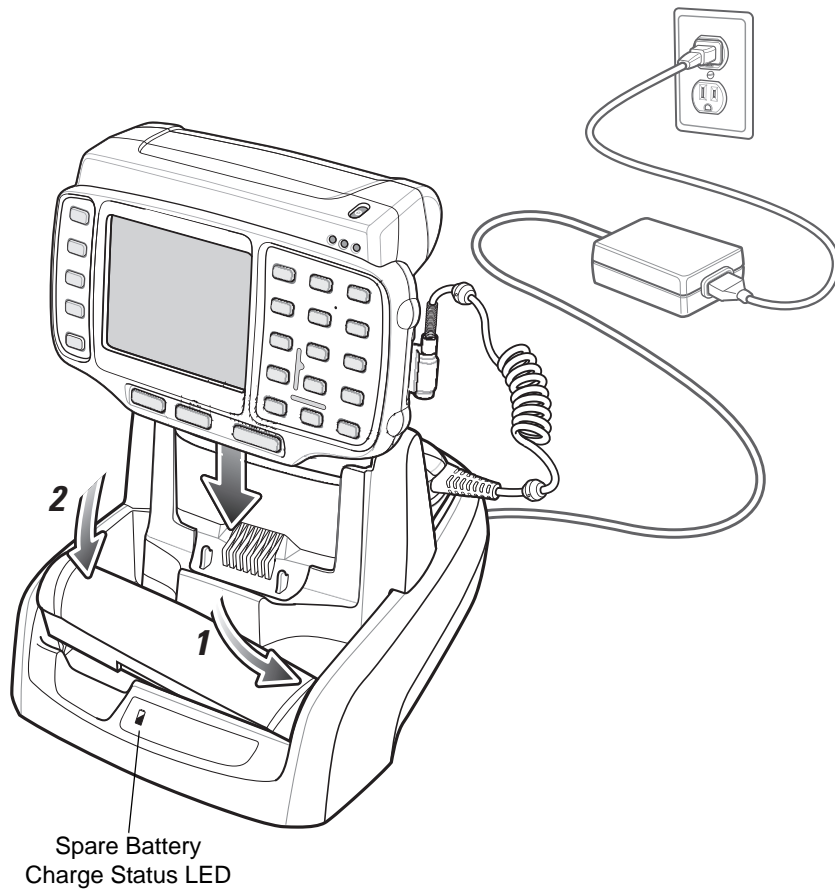

Figure 2-2 Wearable Terminal and Spare Battery Charging

Battery Charging Indicators

The Single Slot USB cradle can charge the wearable terminal's main battery and a spare battery simultaneously. The wearable terminal's amber Charge Status LED indicates the status of the battery charging in the wearable terminal. See [Table 1-1 on page 1-5](#) for charging status indications. The amber Spare Battery Charge Status LED on the cradle (see [Figure 2-1 on page 2-3](#)) indicates the status of the spare battery charging in the cradle. See [Table 2-2](#) for charging status indications. The standard capacity batteries usually charge in less than four hours and the extended capacity battery usually charges in less than eight hours.

Table 2-2 Spare Battery Charge Status LED Indicator

Spare Battery LED (on cradle)	Indication
Off	No spare battery in well; spare battery not placed correctly; cradle is not powered.
Fast Blinking Amber	Charging error: <ul style="list-style-type: none"> • Temperature is too low or too high. • Charging has gone on too long without completing (typically eight hours).
Slow Blinking Amber	Spare battery is charging.
Solid Amber	Charging complete.

Communication Setup

The wearable terminal can communicate with a host computer using the Single Slot USB cradle. By default the wearable terminal is configured to communicate using USB. Ensure that ActiveSync on the host computer is set to allow USB connections.

1. Ensure that ActiveSync was installed on the host computer and a partnership was created.
2. Start ActiveSync if it is not running on the host computer. To start, select **Start > Programs > Microsoft ActiveSync**.

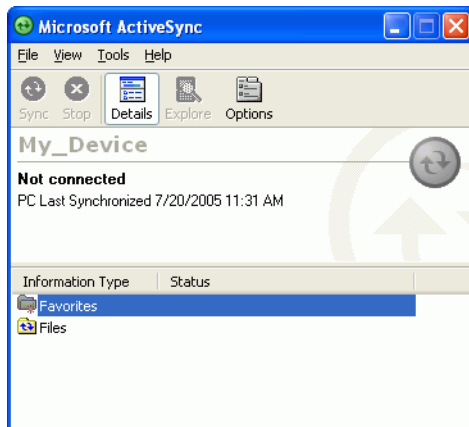

Figure 2-3 ActiveSync - Not Connected

3. In the **ActiveSync** window, select **File > Connection Settings**. The **Connection Settings** window displays.



Figure 2-4 Connection Settings

4. Select **Allow USB connection** check box.
5. Select **OK** to save any changes made.

✓ **NOTE** Every wearable terminal should have a unique device name. Never try to synchronize more than one wearable terminal to the same name. The device name is set in the **System Properties** window.

6. Connect the device to the host computer.

✓ **NOTE** The cradle requires a dedicated port. It cannot share a port with an internal modem or other device. Refer to the computer user manual supplied to locate the serial port(s).

7. Upon connection, synchronization occurs automatically.

Four Slot Ethernet Cradle



CAUTION Ensure that you follow the guidelines for battery safety described in *Battery Safety Guidelines* on page 9-3.

This section describes how to set up and use a Four Slot Ethernet cradle with the wearable terminal.

The Four Slot Ethernet cradle:

- Provides 5.4 VDC power for operating up to four wearable terminals.
- Enables data communication between the wearable terminal (up to four) and a host computer, over an Ethernet network (using a standard 10Base-T Ethernet cable). The CRD4000-4000ER provides a maximum of 100 Mbps data rate. The CRD4001-4001ER provides a maximum of 1 Gbps data rate.
- Simultaneously charges up to four wearable terminals (with batteries installed).

The user cannot ActiveSync using the Four Slot Ethernet cradle. To ActiveSync with a host computer, use the Single Slot USB cradle.

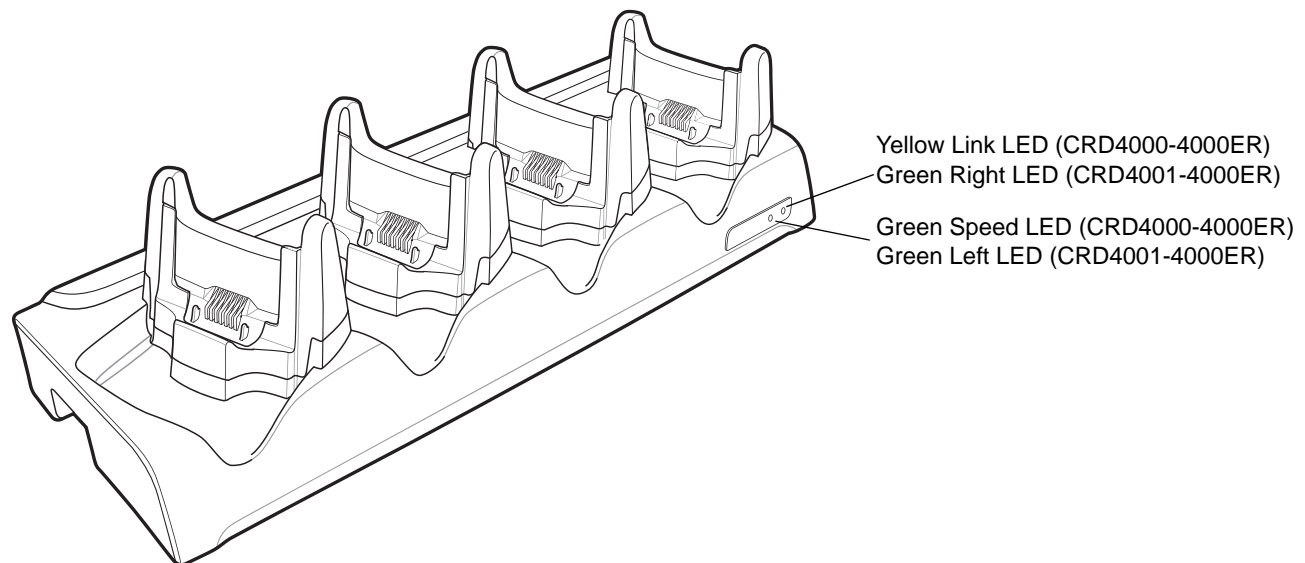

Figure 2-5 Four Slot Ethernet Cradle

CRD4000-4000ER Setup

To setup the Ethernet cradle:

1. Connect one end of an Ethernet cable to a Ethernet switch, router or hub.
2. Connect the other end of the Ethernet cable to the Ethernet Port 1 on the back of the cradle.
3. Connect the DC cable to the output of the power supply.
4. Connect the DC cable to the power input on the back of the cradle.
5. Plug the AC line cord into the power supply.

6. Plug the AC line cord into an AC outlet.

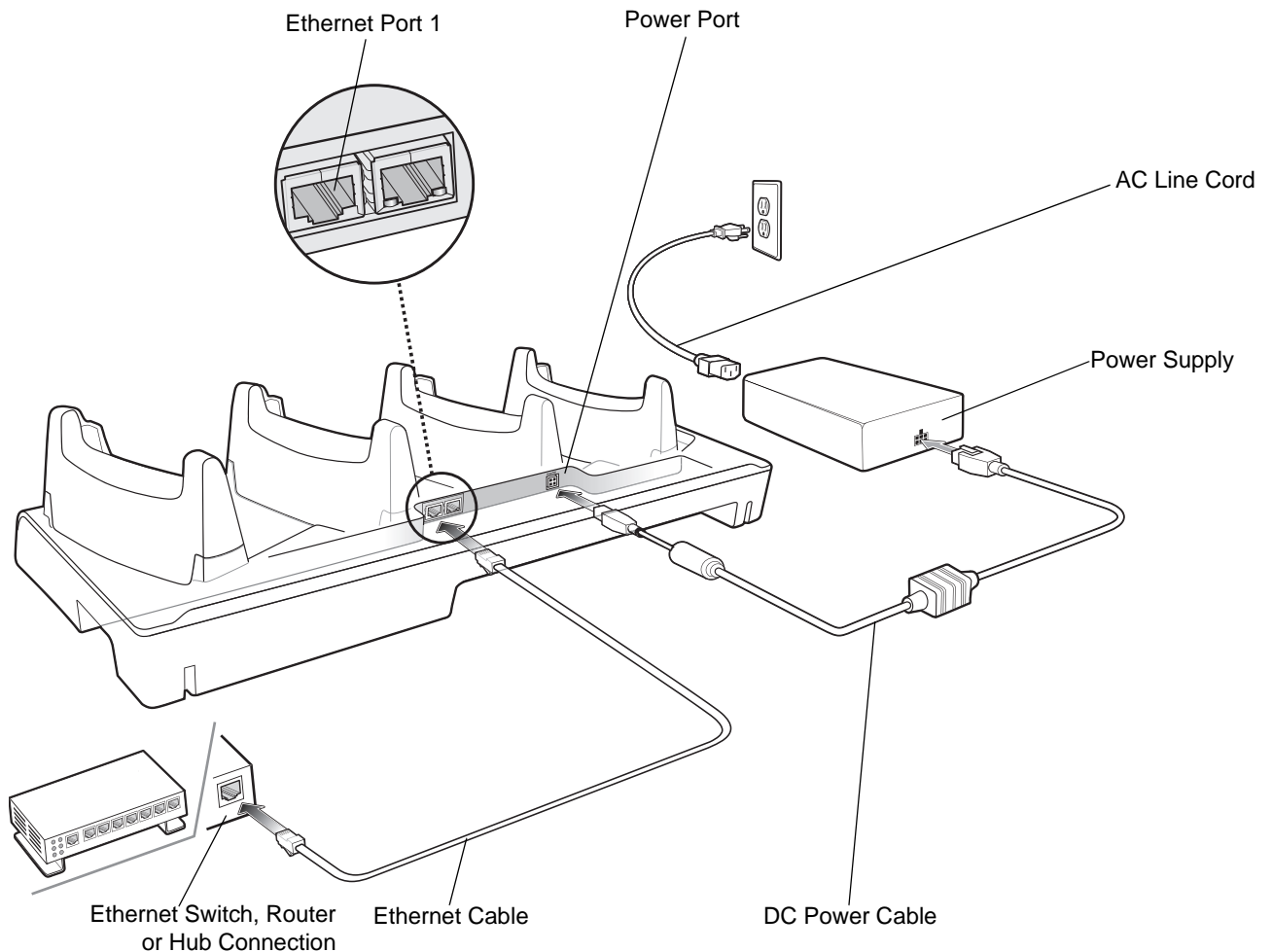

Figure 2-6 CRD4000-4000ER Four Slot Ethernet Cradle Setup

Daisychaining CRD4000-4000ER Cradles

To connect several cradles to an Ethernet network, up to four Ethernet cradles may be daisychained. Daisy-chaining should not be attempted when the main Ethernet connection to the first cradle is 10 Mbps as throughput issues will certainly result. The Speed LED and the Link LED on the Ethernet port 2 function in the same way as the Speed LED and the Link LED on the front of the cradle.

To daisychain cradles:

1. Connect one end of the daisychain Ethernet cable (either straight or twisted cable can be used) to the Ethernet Port 2 port of the first cradle.
2. Connect the other end of the Ethernet cable to the Ethernet Port 1 port on the second cradle.
3. Connect additional cradles as described in step 1 and 2.

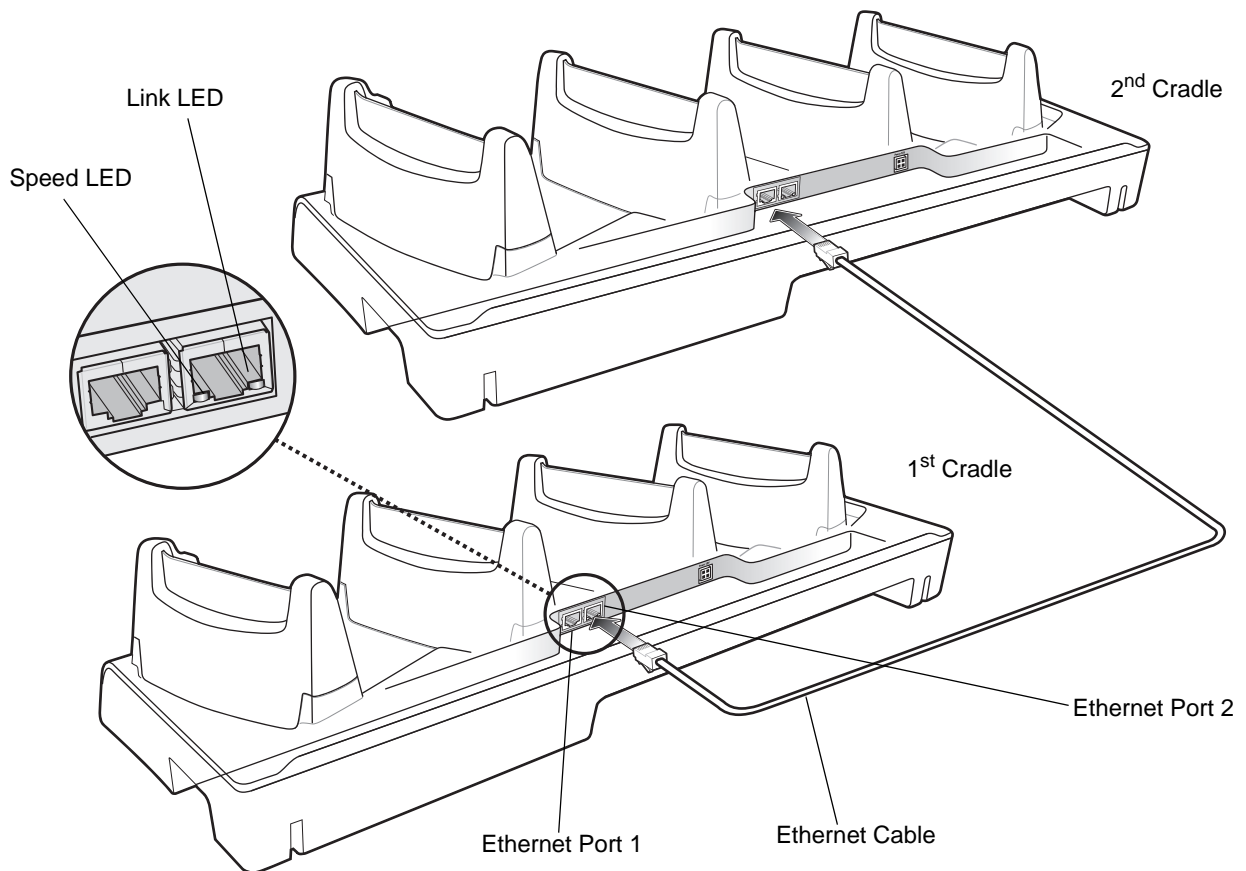

Figure 2-7 *Daisy chaining Four Slot Ethernet Cradles*

LED Indicators (CRD4000-4000ER)

There are two LEDs on the front of the cradle and two on the Ethernet 2 port. The green Speed LED lights to indicate that the transfer rate is 100 Mbps. When the LED is not lit the transfer rate is 10 Mbps. The yellow Link LED blinks to indicate activity, or stays lit to indicate that a link is established. When it is not lit it indicates that there is no link.

Table 2-3 *CRD4000-4000ER LED Indicators*

Data Rate	Speed LED	Link LED
100 Mbps	On	On/Blink
10 Mbps	Off	On/Blink

CRD4001-4000ER Setup

To setup the Ethernet cradle:

1. Connect one end of an Ethernet cable to a Ethernet switch, router or hub.
2. Connect the other end of the Ethernet cable to the Primary Port on the back of the cradle.
3. Connect the DC cable to the output of the power supply.

4. Connect the DC cable to the power input on the back of the cradle.
5. Plug the AC line cord into the power supply.
6. Plug the AC line cord into an AC outlet.

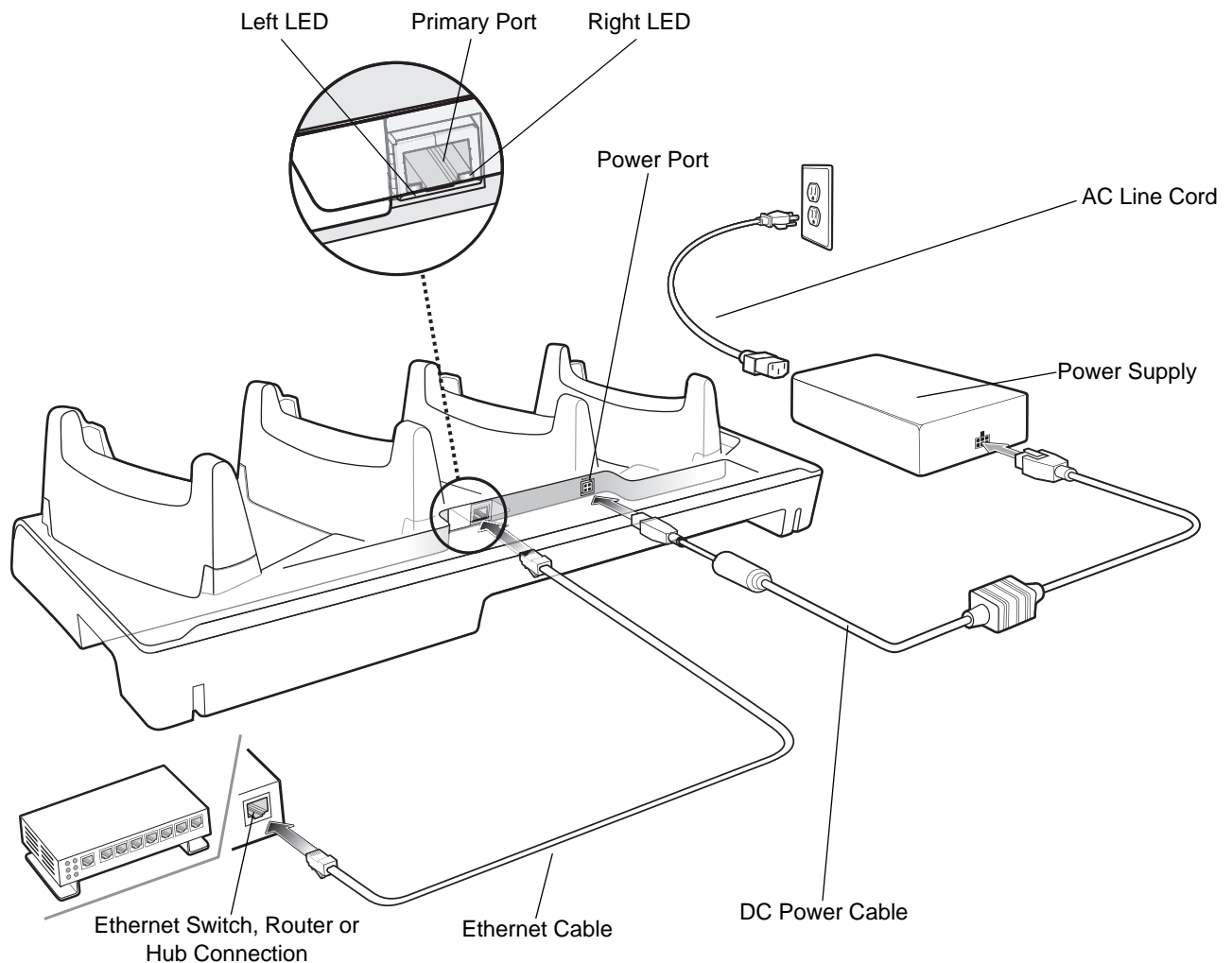

Figure 2-8 CRD4001-4000ER Four Slot Ethernet Cradle Setup

Daisy-chaining CRD4001-4000ER Cradles

To connect several cradles to an Ethernet network, up to four Ethernet cradles may be daisychained. Daisy-chaining should not be attempted when the main Ethernet connection to the first cradle is 10 Mbps as throughput issues will certainly result. The LEDs on the Primary Ethernet port function in the same way as the LEDs on the front of the cradle.

To daisychain cradles:

1. Lift or remove the label covering the Secondary Port on the back of the first cradle.
2. Connect one end of the daisychain Ethernet cable (either straight or twisted cable can be used) to the Secondary Port of the first cradle.
3. Connect the other end of the Ethernet cable to the Primary Port of the second cradle.
4. Connect additional cradles as described in steps 1 and 2.

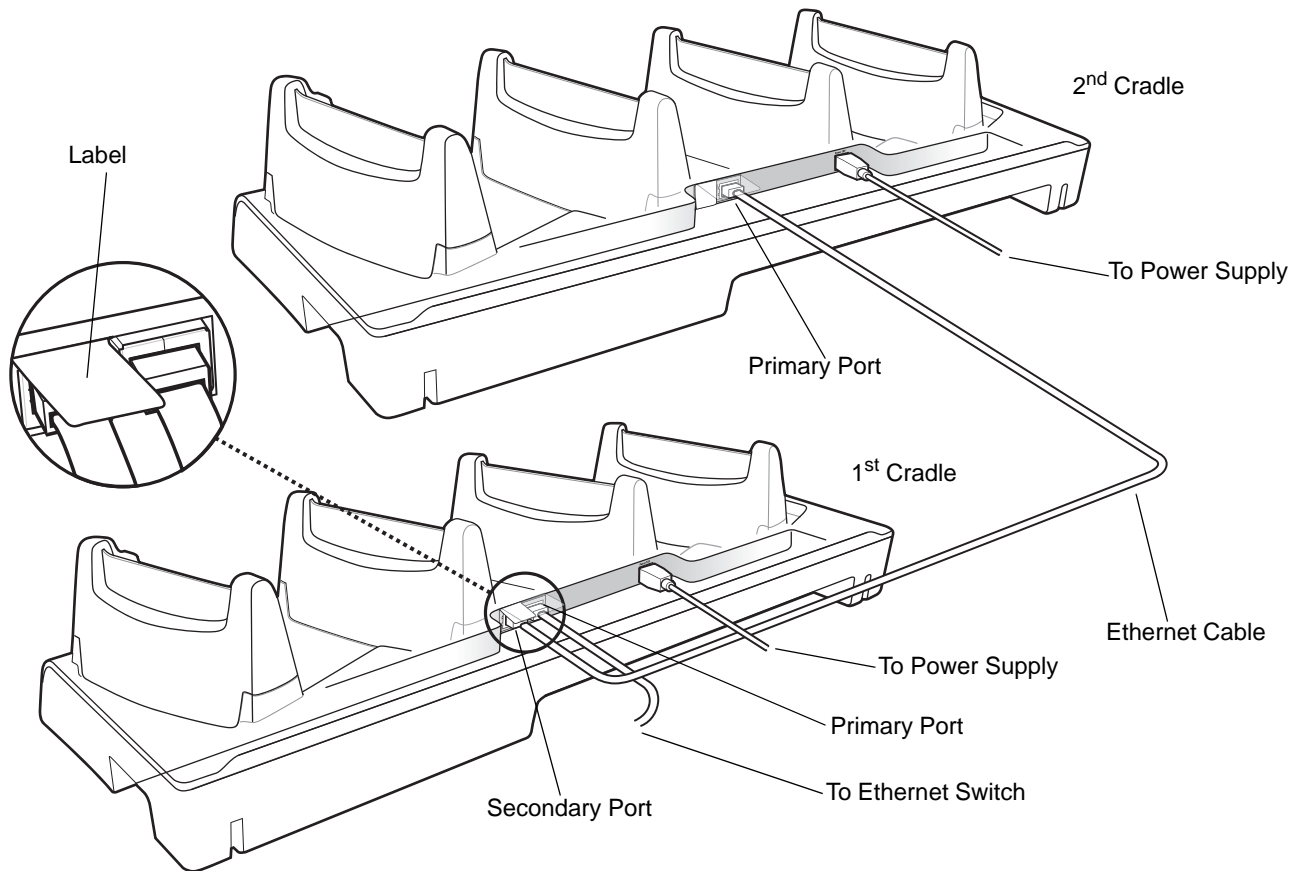

Figure 2-9 *Daisy chaining Four Slot Ethernet Cradles*

LED Indicators (CRD4001-4000ER)

There are two green LEDs on the front of the cradle and two green LED on the Primary Ethernet port. These green LEDs light and blink to indicate the data transfer rate. When the LEDs are not lit the transfer rate is 10 Mbps.

Table 2-4 *CRD4001-4000ER LED Indicators*

Data Rate	Left LED	Right LED
1 Gbps	On/Blink	Off
100 Mbps	Off	On/Blink
10 Mbps	Off	Off

Ethernet Cradle Drivers

The Ethernet cradle drivers are pre-installed on the wearable terminal and initiate automatically when the wearable terminal is placed in a properly connected Four Slot Ethernet cradle. When the wearable terminal is inserted into the Four Slot Ethernet cradle, the LAN icon appears in the taskbar and indicates that the wearable terminal is connected to a network.

✓ **NOTE** The device's IP address can only be viewed on the WT41N0.

On a touch screen WT41N0, to view the IP Address double-tap the LAN icon to open the SS1VNDIS1 window. The window displays the TCP/IP information for the WT41N0.

On a non-touch WT41N0, to view the IP Address assigned to the WT41N0 open a **Command Prompt** window and enter `ipconfig`.

1. Press **CTRL > ESC**.
2. Use the navigation keys to select **Programs**.
3. Press **ENTER** to open the sub-menu.
4. Use the navigation keys to select **Command Prompt**.
5. Press **ENTER**. The **Command Prompt** window displays.
6. Enter `ipconfig`. The window displays the IP Address assigned to the wearable terminal.

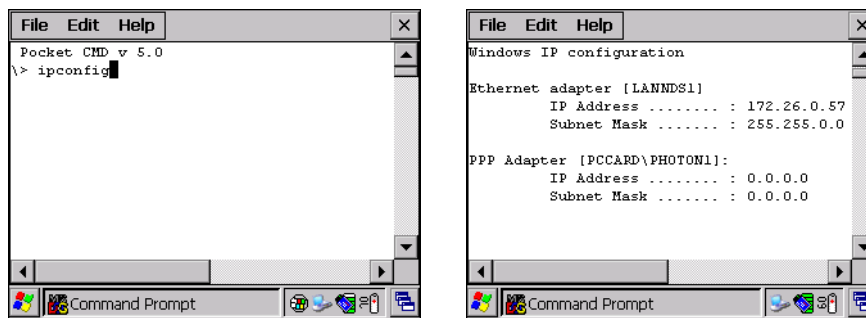

Figure 2-10 Ethernet IP Address

Charging and Communication

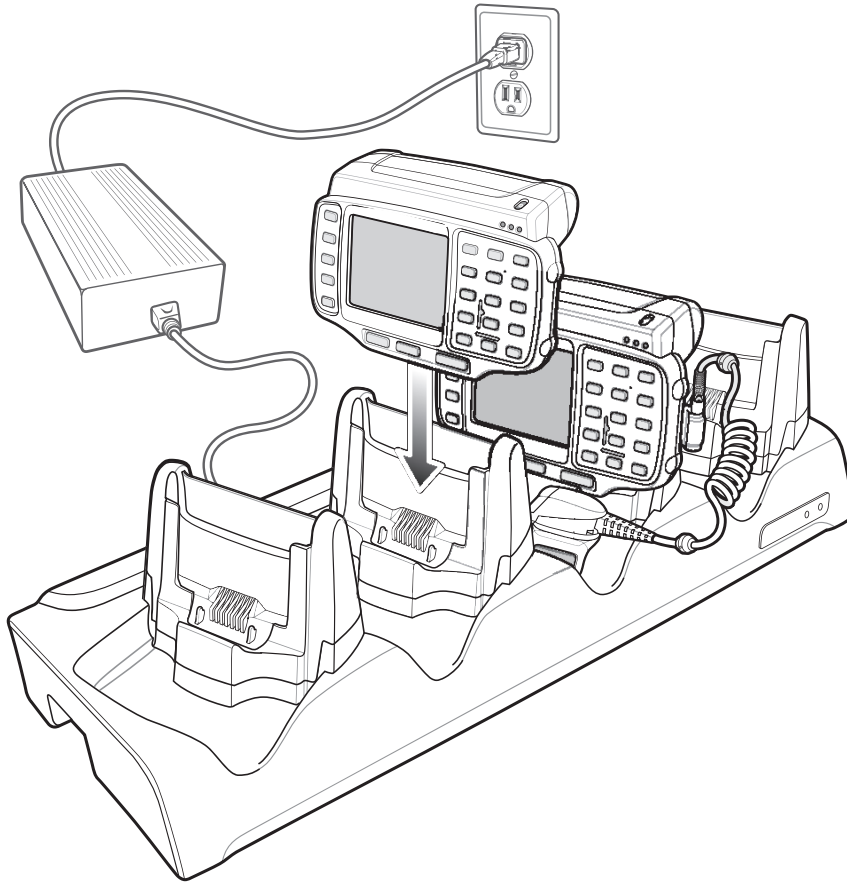

Figure 2-11 Four Slot Ethernet Cradle

Battery Charging Indicators

The wearable terminal's amber Charge Status LED shows the status of the battery charging in the wearable terminal. See [Table 1-1 on page 1-5](#) for charging status indications. The standard capacity battery usually charges in less than four hours and the extended capacity battery usually charges in less than eight hours.

Four Slot Spare Battery Charger



CAUTION Ensure that you follow the guidelines for battery safety described in *Battery Safety Guidelines* on page 9-3.

This section describes how to set up and use the Four Slot Spare Battery Charger to charge up to four spare batteries.

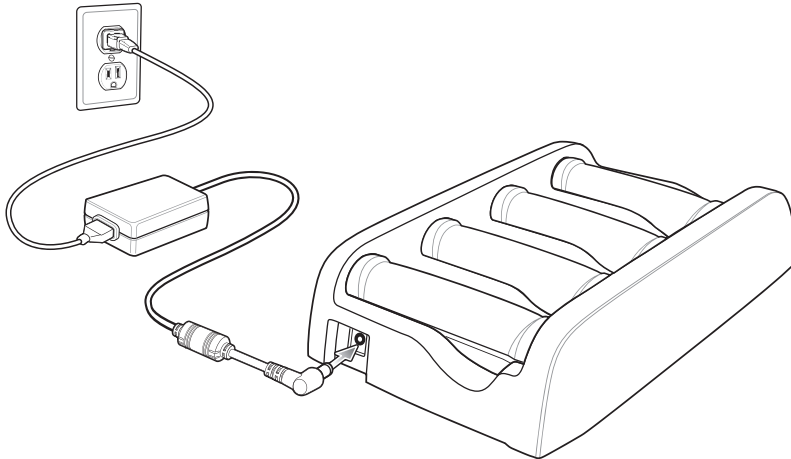

Figure 2-12 Four Slot Spare Battery Charger Setup



CAUTION Use only a Zebra approved power supply output rated 12 VDC and minimum 3.3 A. Use of an alternative power supply will void the product warranty and may cause product damage. Refer to the *WT41N0 User Guide* for the power supply regulatory compliance statement.

Spare Battery Charging

1. Connect the charger to a power source.
2. Insert the battery into a spare battery charging slot and press down on the battery to ensure proper contact.

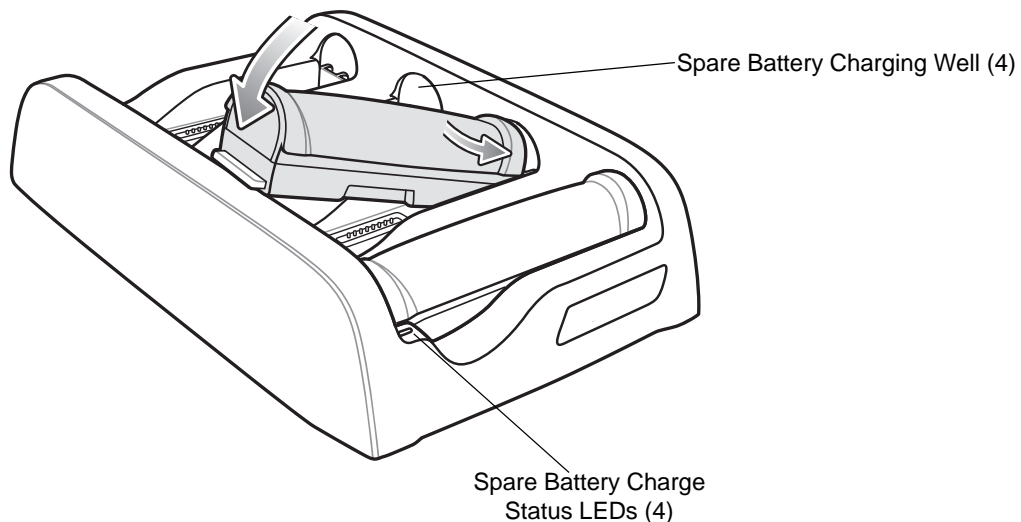

Figure 2-13 Spare Battery Charging

Battery Charging Indicators

Each battery charging well has an amber Spare Battery Charge Status LED. (see [Figure 2-13 on page 2-13](#)). See [Table 2-5](#) for charging status indications.

The standard capacity battery usually charges in less than four hours and the extended capacity battery usually charges in less than eight hours.

Table 2-5 Spare Battery Charge Status LED Indicators

LED	Indication
Off	No spare battery in slot; spare battery not placed correctly; cradle is not powered.
Fast Blinking Amber	Charging error: <ul style="list-style-type: none">• Temperature is too low or too high.• Charging has gone on too long without completing (typically eight hours).
Slow Blinking Amber	Spare battery is charging.
Solid Amber	Charging complete.

Wall Mount Bracket

Use the wall mounting bracket to mount a Four Slot Ethernet cradle and a Four Slot Battery Charge together on a wall.

To mark the screw holes for mounting the bracket use the wall mounting bracket as a template. Place the bracket onto the wall, level and mark the five screw hole locations.

1. Install top three screws into the wall.
2. Align the top three mounting holes with the screws.
3. Place mounting bracket on screws.
4. Secure the mounting bracket to the wall by tightening the three screws.
5. Install and secure two screws at the bottom of the bracket.

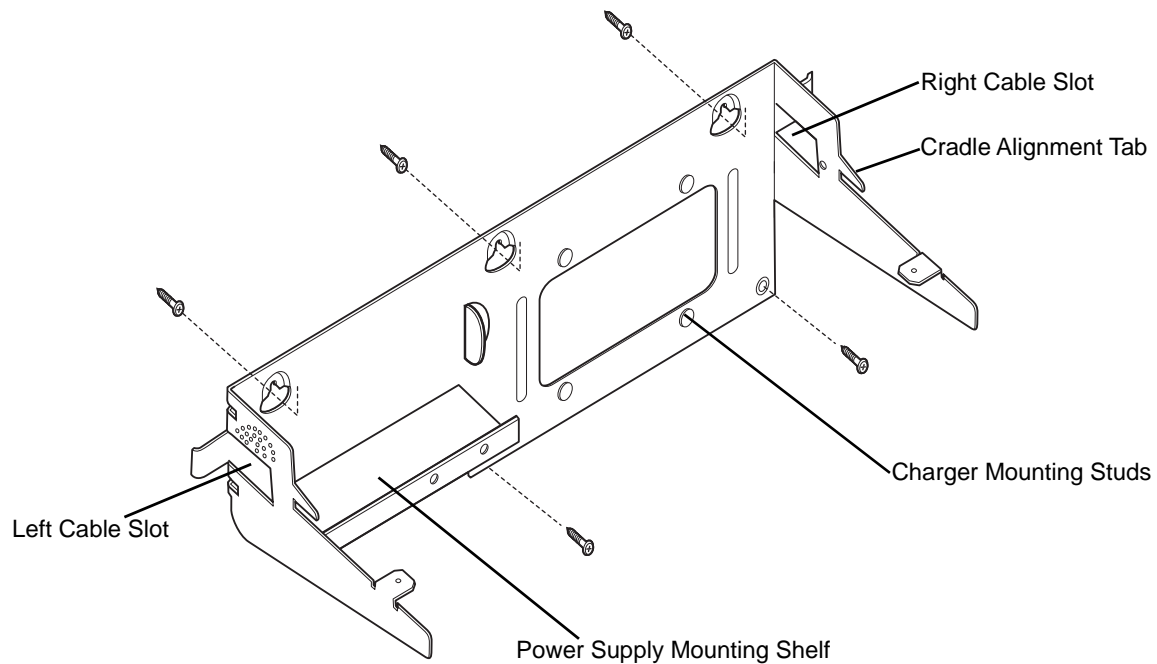

Figure 2-14 *Mounting the Bracket*

Power Supply Installation

Place power supply onto mounting shelf with the DC output connector and fan facing out and with the fan on top.

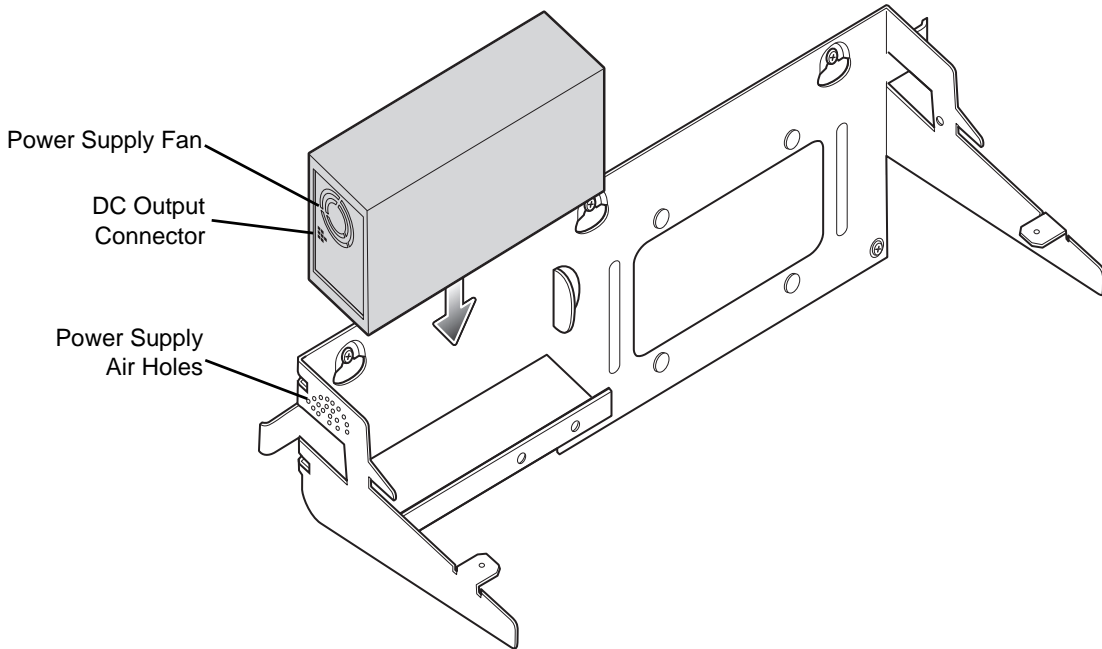

Figure 2-15 *Installing the Power Supply*

Four Slot Ethernet Cradle Installation

1. Align the two slots in the back of the cradle with the two cradle alignment tabs on the bracket.

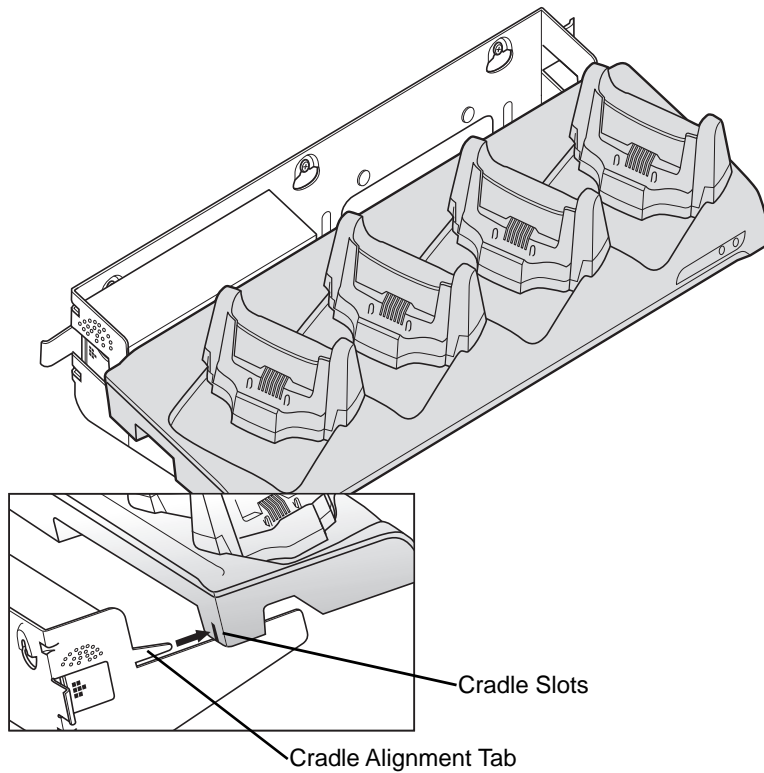

Figure 2-16 *Aligning the Slots in the Cradle with Mounting Bracket Tabs*

2. Secure the cradle to the mounting bracket with two M4.0 screws supplied with the bracket.

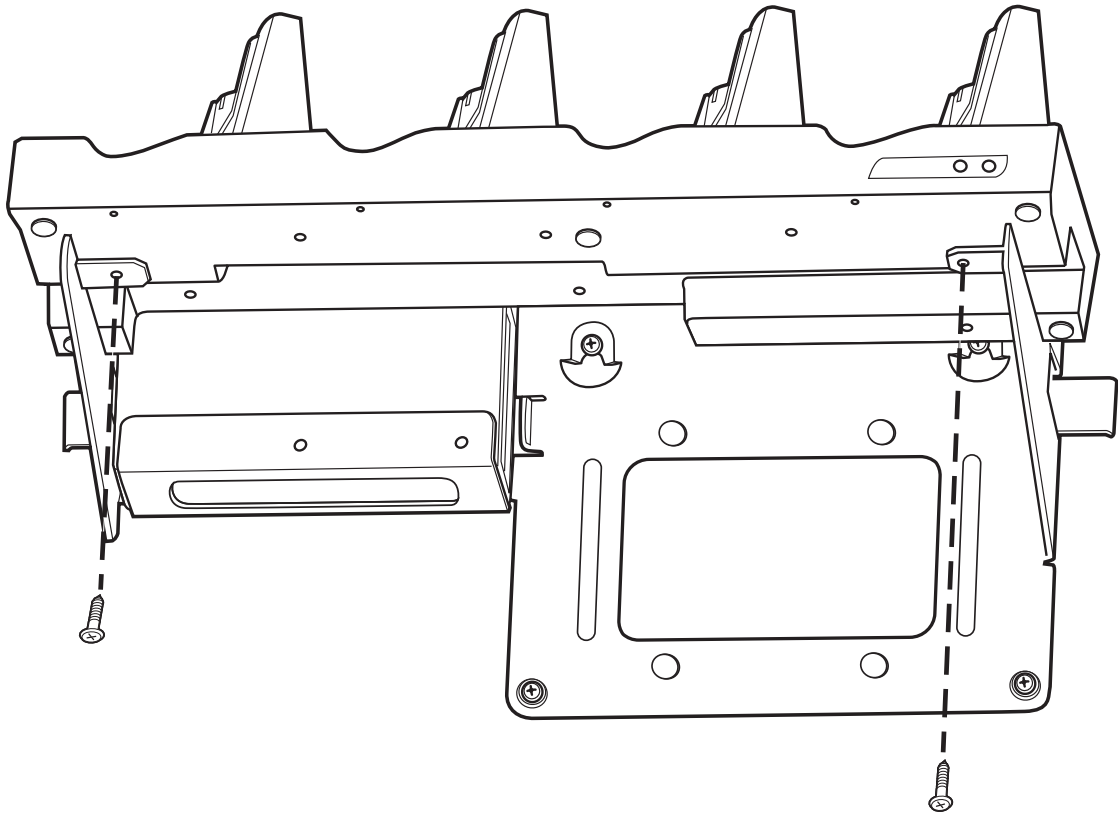

Figure 2-17 *Securing the Four-Slot Ethernet Cradle to the Mounting Bracket*

Four Slot Battery Charger Installation

The Four Slot Spare Battery Charger has four mounting slots on the back. Around the slots are guides that assist in proper alignment of the charger onto the mounting bracket. Gravity holds the charger in place.

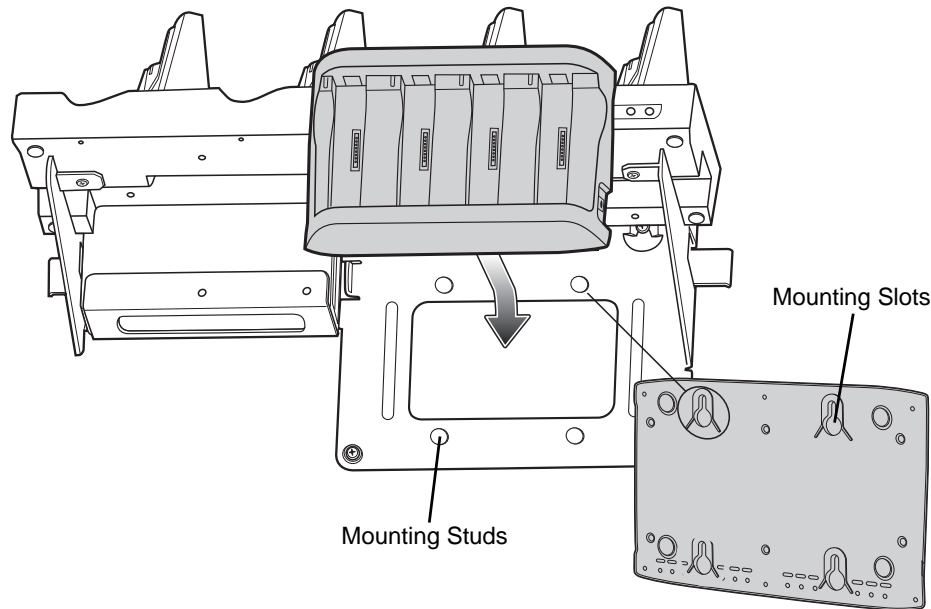

Figure 2-18 *Installing the Battery Charger onto the Mounting Bracket*

Position the charger over the mounting studs and slide the charger into place.

Ensure that the charger is seated properly.

Wiring

The AC line cord provides AC power to the power supply. The mounting bracket power cable provides power from the power supply to the Four Slot Ethernet cradle and the Four Slot Spare Battery Charger. Ethernet cables (not supplied) connects the cradle to the local network and to another cradle, if required.

Ensure that the AC line cord is long enough to reach from the AC power source to the power supply.

1. Route the AC line cord through the right cable slot of the bracket.
2. Plug the AC line cord into the power supply AC input connector.
3. Route the power supply connector of the power cable through the cradle channel and out the left side of the cradle.
4. Plug the power cable connector into the DC output connector on the power supply.
5. Plug the cradle power plug into the Four Slot Ethernet cradle input power connector.
6. Plug the charger power plug onto the Four Slot Spare battery Charger input power connector.
7. Plug one end of the Ethernet cable into the appropriate connector on the Four Slot Ethernet cradle.
8. Route the cables as shown in [Figure 2-19](#) and [Figure 2-20](#).
9. Use two tie-wraps to secure the power cable Y connection to the power supply mounting shelf.

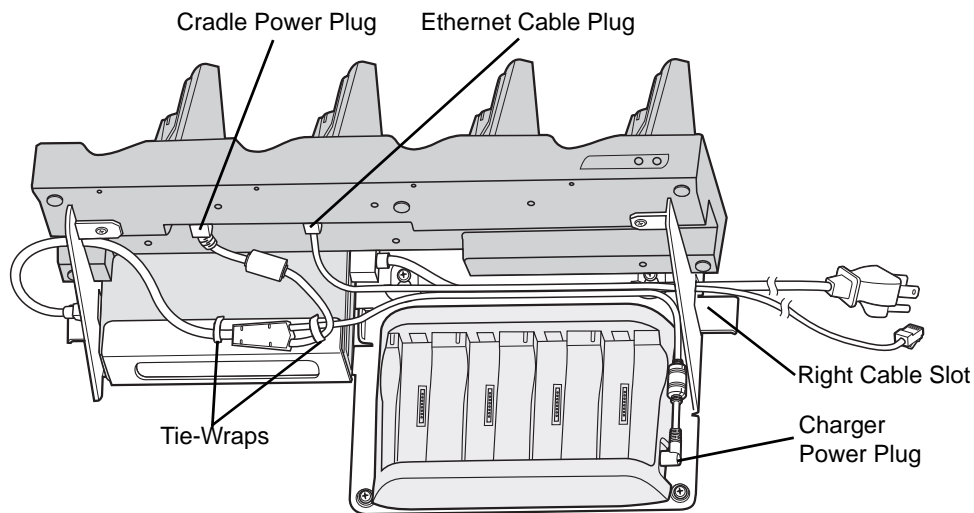

Figure 2-19 Cable Routing

10. Use one tie-wrap to secure the AC line cord and Ethernet cable to the mounting bracket.
11. Use two tie-wraps to secure the charger power lead, the AC line cord and Ethernet cable (if required) together as shown below.

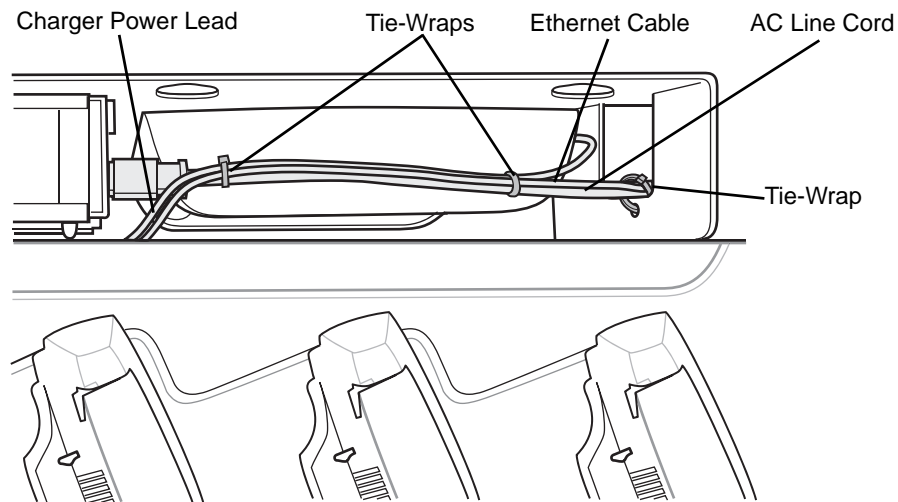

Figure 2-20 Routing Cables

12. Plug the AC line cord into an AC power source.

Placing a Battery in the Charger

When placing a spare battery into the Four Slot Spare Battery Charger, ensure proper orientation of the battery.

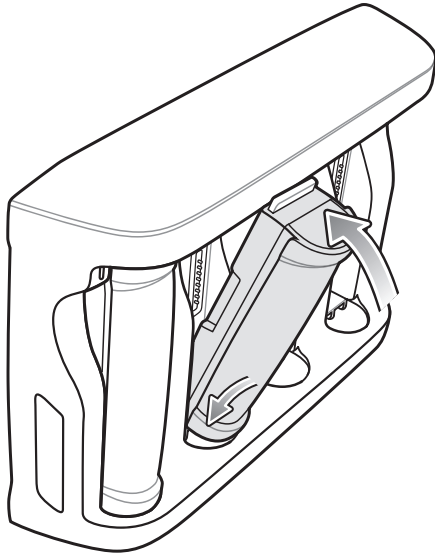

Figure 2-21 *Inserting a Battery into the Battery Charger*

Mounting Multiple Brackets

When installing multiple brackets on a wall:

- Each mounting bracket must be 25.4 cm (10 in.) from the top of one bracket to the top of the next bracket.
- The bottom of the last bracket must be at least 61 cm (24 in.) from the floor.
- When mounting brackets next to each other the tabs must at least touch each other to ensure minimum distance between brackets.

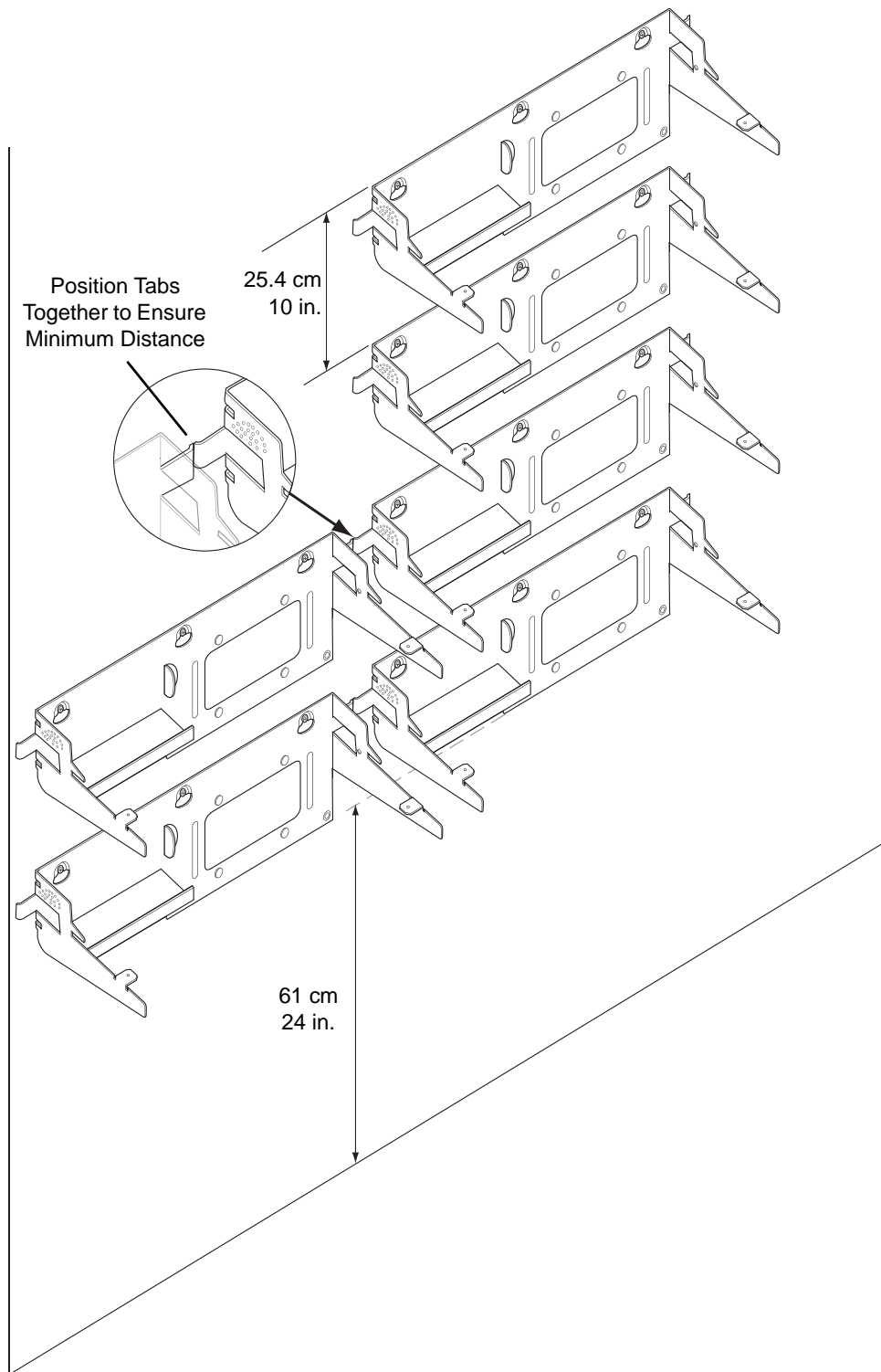

Figure 2-22 *Installing Multiple Mounting Brackets*

Navigating the Wearable Terminal with an External Input Device

To assist in development, an external input device, such as a mouse, can be used to navigate the desktop and applications instead of using the wearable terminal keypad.

- USB devices
 - mouse
 - keyboard
 - hub
- Bluetooth mouse.

USB Device

✓ **NOTE** The wearable terminal must be inserted into the Single Slot USB cradle to use a USB input device.

The following is required to connect a USB device:

- a commercially-available USB cable or Zebra's USB Adapter with a mini USB A connector on one end and a USB A Female connector on the other end.
- a USB device
 - a USB keyboard
 - a USB mouse
 - a USB hub (optional).

Connect the mini USB A connector end into the USB connector on the back of the Single Slot USB cradle. The cradle automatically detects the USB A connector and places the wearable terminal into USB host mode. Connect the USB device (mouse or keyboard) connector into the USB A Female connector. You can also connect both a mouse and keyboard to a hub and the hub to the USB A Female connector.

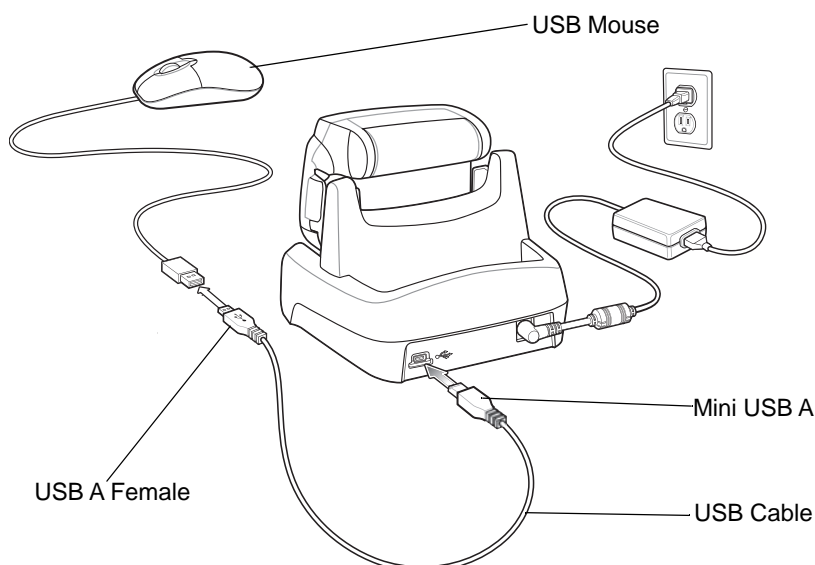

Figure 2-23 USB Mouse Connection to the Single Slot USB Cradle

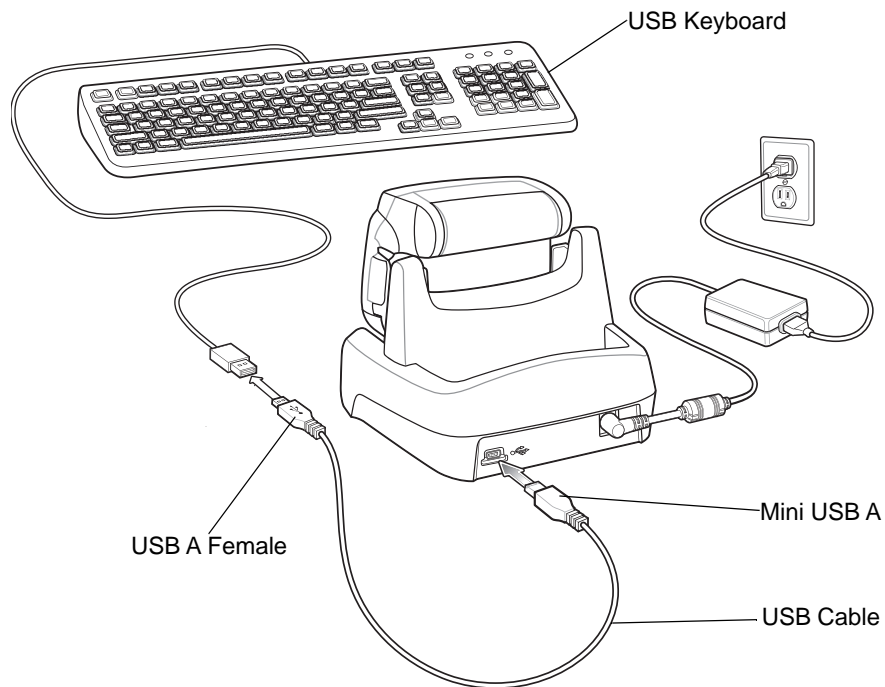

Figure 2-24 *USB Keyboard Connection to the Single Slot USB Cradle*

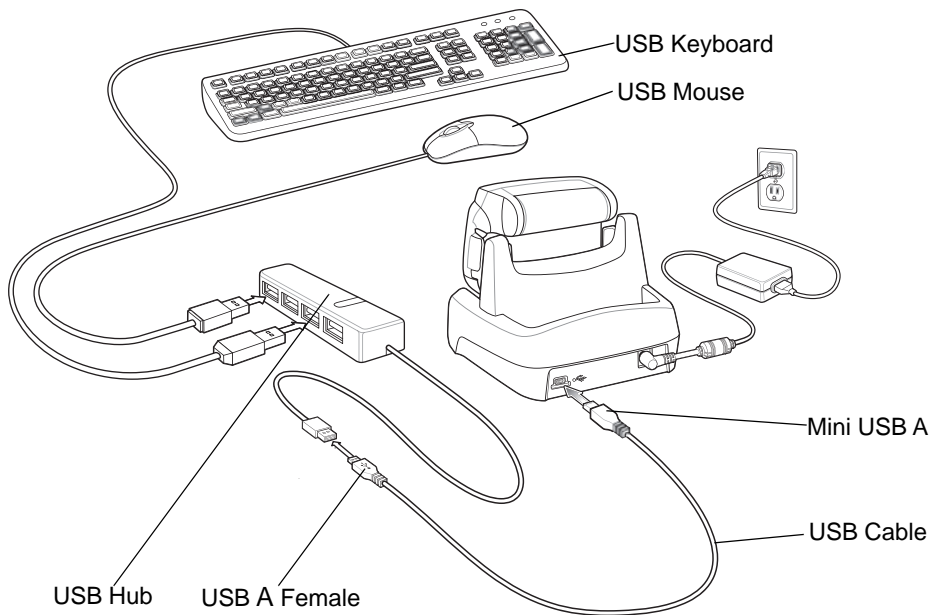

Figure 2-25 *USB Mouse/Keyboard/Hub Connection to the Single Slot USB Cradle*

Connector Shroud

✓ **NOTE** Use only on the RS409 or RS419 with extended cable.

Assembly

1. Remove cable from wearable terminal, if required.
2. Align the cable connector with the connector shroud bottom housing. Ensure that the disconnect button on the connector faces up.

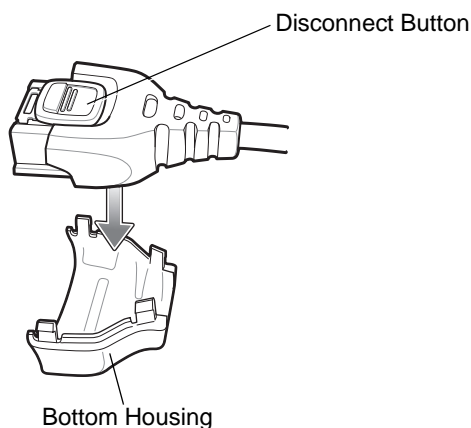

Figure 2-26 *Installing Bottom Housing*

3. Place the cable connector into the shroud bottom housing as shown.

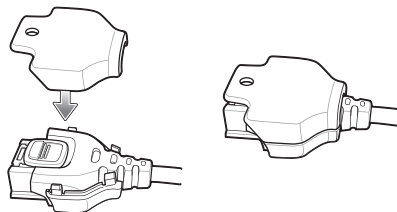

Figure 2-27 *Installing Top Housing*

4. Press the top housing into the bottom housing. The housings will snap together.
5. Plug the cable connector into the wearable terminal connector.

Disconnecting the Cable from the Wearable Terminal

✓ **NOTE** Follow the instructions below when disconnecting the cable connector and shroud from the wearable terminal. Once the shroud is installed on the connector, do not disassemble the shroud by prying it apart.

1. Turn the wearable terminal over to expose the top housing of the shroud.
2. Push the tip of a ball-point pen through the hole in the connector shroud top housing. The connector disengages from the wearable terminal.

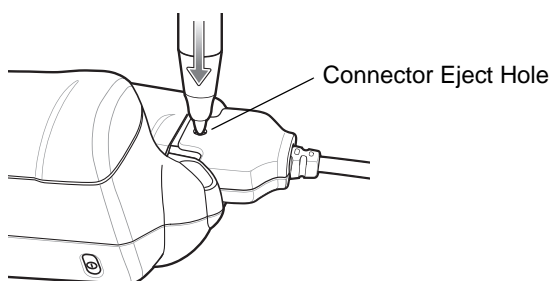

Figure 2-28 *Disconnecting Connector with Shroud*

CHAPTER 3 SYNCHRONIZATION

Introduction

Synchronization lets the user manage information between an WT41N0 and a host computer so that changes made either on the WT41N0 or on the host computer appear in both places. Download and install synchronization software to the host computer (either Microsoft ActiveSync for Windows XP or Windows Mobile Device Center (WMDC) for Windows Vista and Windows 7) in order to use the sync feature. Visit www.microsoft.com on the host computer for details.

The synchronization software:

- Allows working with WT41N0-compatible applications on the host computer. The sync software replicates data from the WT41N0 to view, enter, and modify data on the host computer.
- Synchronizes files between the WT41N0 and the host computer, converting the files to the correct format.
- Backs up the data stored on the WT41N0. Synchronization is a one-step procedure that ensures the data is always safe and up-to-date.
- Copies (rather than synchronizes) files between the WT41N0 and the host computer.
- Controls when synchronization occurs by selecting a synchronization mode. For example, synchronize continuously while the WT41N0 is connected to the host computer, or synchronize only on command.
- Selects the types of information to synchronize and control how much data is synchronized.

Installing the Sync Software

To download and install either Microsoft ActiveSync (for Windows XP) or WMDC (for Windows Vista and Windows 7), visit www.microsoft.com and follow the instructions provided.

WT41N0 Setup

- ✓ **NOTE** Microsoft recommends installing the synchronization software on the host computer before connecting the WT41N0.

The WT41N0 can be set up to communicate with a USB connection. The WT41N0 communication settings must be set to match the communication settings used with ActiveSync or WMDC.

1. On the WT41N0 tap **Start > Settings > Control Panel > PC Connection**. The **PC Connection Properties** window appears.

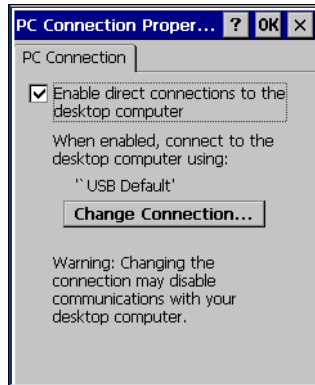

Figure 3-1 PC Connection Properties Window

2. Tap the **Change Connection** button.
3. Select the connection type from the drop-down list.
4. Tap **OK** to exit the **Change Connection** window and tap **OK** to exit the **PC Connection Properties** window.
5. Proceed with installing ActiveSync or WMDC on the host computer and setting up a partnership.

Setting Up a Sync Connection

Set up a Sync connection using Windows XP or Windows 7.

ActiveSync (Windows XP)

To set up a Sync connection using Windows XP:

1. Select **Start > Programs > Microsoft ActiveSync** on the host computer. The **ActiveSync Window** displays.

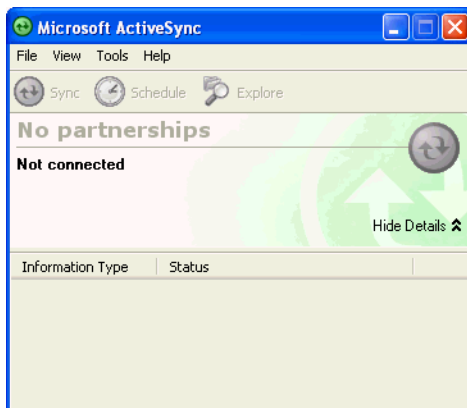

Figure 3-2 ActiveSync Window

✓ **NOTE** Assign each WT41N0 a unique device name. Do not try to synchronize more than one WT41N0 to the same name.

- In the **ActiveSync** window, select **File > Connection Settings**. The **Connection Settings** window appears.



Figure 3-3 Connection Settings Window

- Select **Allow USB connections** check box.
- Select the **Show status icon in taskbar** check box.
- Select **OK** to save any changes made.

Windows Mobile Device Center (Windows 7)

To set up a Sync connection using Windows 7:

- Select **Start > All Programs > Windows Mobile Device Center** on the host computer.



Figure 3-4 Windows Mobile Device Center Window

- In the WMDC window, under **Mobile Device Settings**, click **Connection settings**.

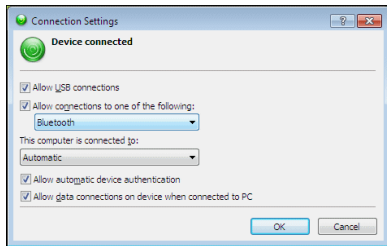

Figure 3-5 Connection Settings Window

3. Select **Allow USB connections** and adjust any additional settings as needed.
4. Click **OK** to save your settings.

Setting up a Partnership

To set up a partnership:

1. If the **Get Connected** window does not appear on the host computer, select **Start > All Programs > Microsoft ActiveSync**.
2. Select if you want to create synchronize with the host computer or to connect as a guest.
3. Click **Next**.

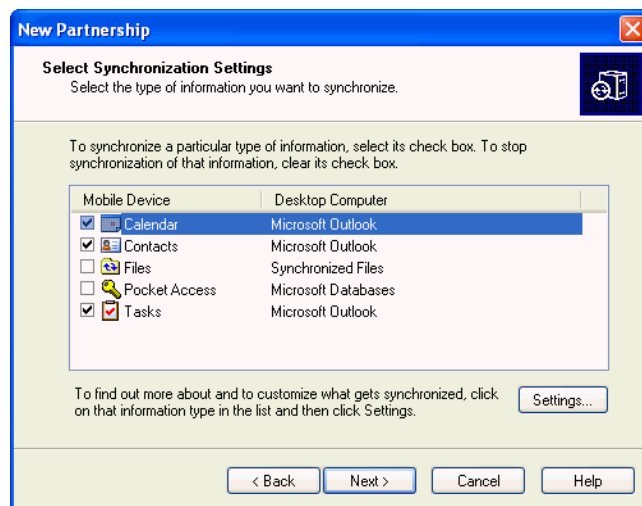

ActiveSync

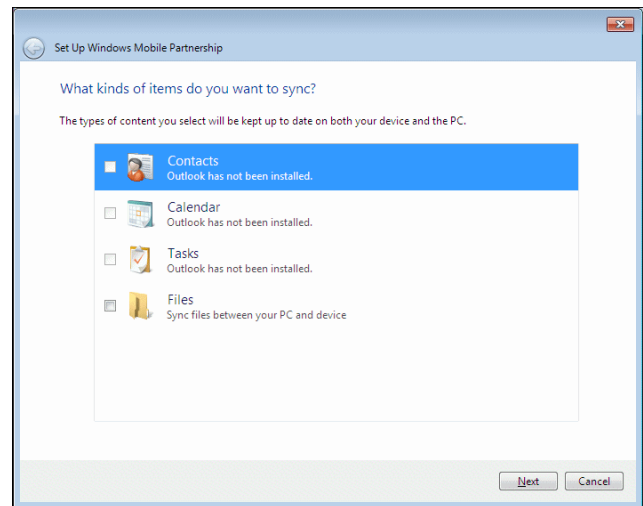

WMDC

Figure 3-6 Select Synchronization Setting Window

4. Select the appropriate settings and click **Next**.

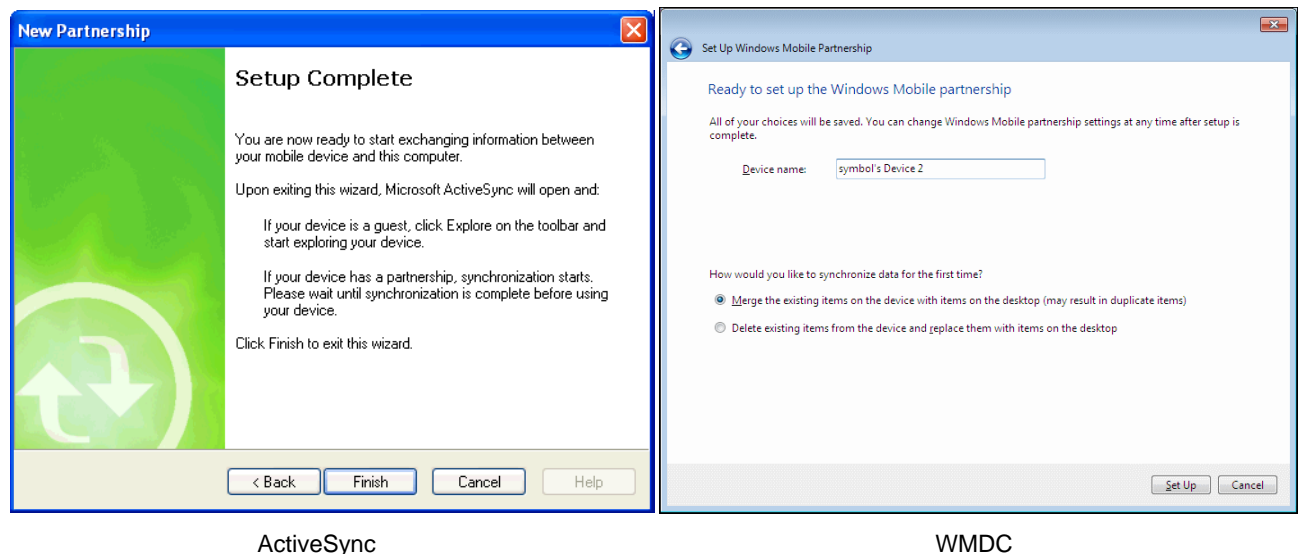

ActiveSync

WMDC

Figure 3-7 Setup Complete Window

5. Click **Finish** or **Setup**.

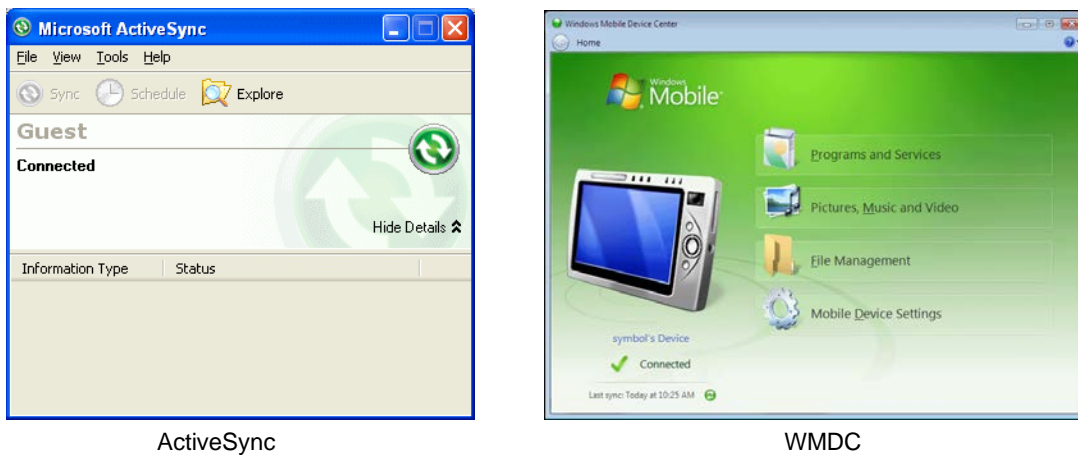

ActiveSync

WMDC

Figure 3-8 Connected Window

During the first synchronization, information stored on the WT41N0 is copied to the host computer. When the copy is complete and all data is synchronized, the WT41N0 can be disconnect from the host computer.

- ✓ **NOTE** The first synchronization operation must be performed with a local direct connection. To retain partnerships after a cold boot, capture partnership registry information in a .reg file and save it in the Flash File System, detailed information is provided in the EMDK Windows CE Help File for the Zebra WT41N0.

For more information about using ActiveSync or WMDC, start the application on the host computer, then see Help.

CHAPTER 4 VOICE ONLY WT41N0 REMOTE CONTROL

Introduction

Since the Voice Only WT41N0 does not have a display, access to settings and controls must be done using a remote display software, such as MotoRC or ActiveSync Remote Display.

MotoRC Software

Download the MotoRC application from the Zebra Support Central web site: <http://www.zebra.com/support>. Follow the instructions provided with the software to install on a host computer.

Microsoft ActiveSync Remote Display Software

Download Windows Mobile Power Toys from the Microsoft web site: <http://www.microsoft.com>. Follow the instructions with the software to install on a host computer.

Ensure that ActiveSync is installed on the host computer. See [Chapter 3, Synchronization](#) for more information.

Connection to Host Computer

To connect the Voice Only WT41N0 to a host computer:

1. Connect the Single Slot Serial/USB cradle to the host computer. See *Single Slot USB Cradle* on page 2-3 for setup instructions.
2. Insert the Voice Only WT41N0 into the cradle.
3. If ActiveSync was installed properly, the host computer automatically detects the Voice Only WT41N0 and begins ActiveSync. The **ActiveSync** window appears.
4. Select the **Yes** radio button to create a partnership with the host computer or select **No** radio button to connect as a guest.
5. Click **Next**. The **Microsoft ActiveSync** window indicates that it is connected to the Voice Only WT41N0.

MotoRC Connection

To control the Voice Only WT41N0 using the MotoRC software:

1. On the host computer, click **Start > Programs > MSP > MotoRC > Run Remote Control**. The Run **Remote Control** DOS window opens followed by the **Remote Control** window.

UI Control Icon

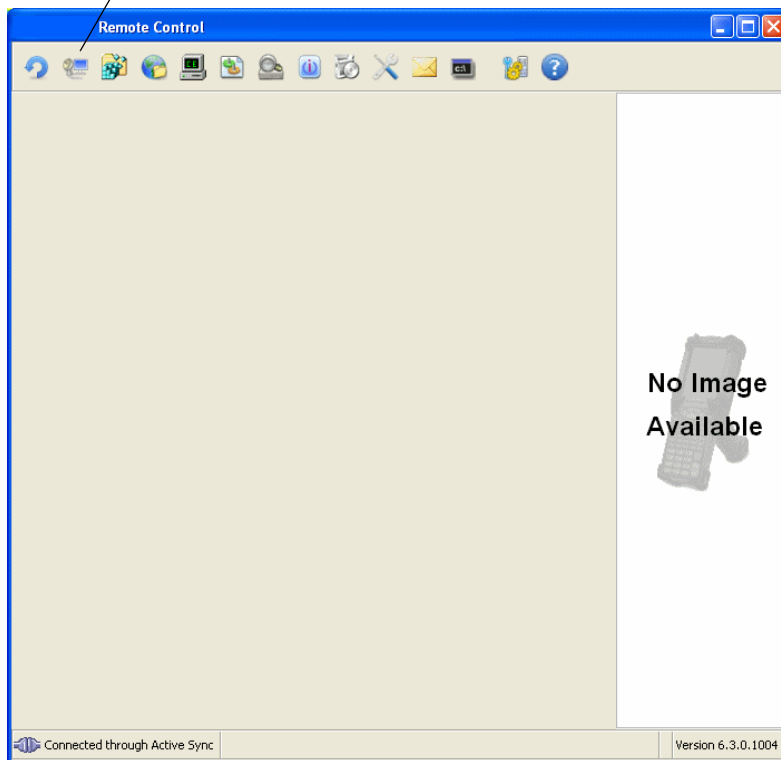

Figure 4-1 Remote Control Window

2. Click on the **UI Control** icon to display the Voice Only WT41N0 desktop.

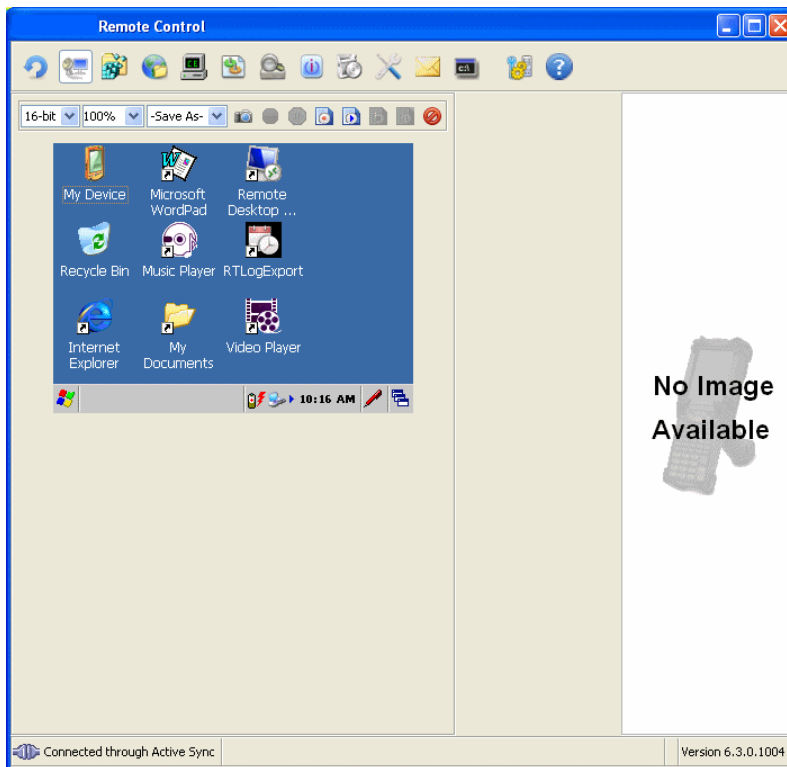

Figure 4-2 Remote Control Window with Voice Only WT41N0 Desktop

3. Use the host computer mouse to control the Voice Only WT41N0 desktop.
4. When finished, close the **Remote Control** and **Run Remote Control** window.

Microsoft ActiveSync Remote Display Connection

To control the Voice Only WT41N0 using the Microsoft ActiveSync Remote Display software:

1. On the host computer, click **Start > Programs > ActiveSync Remote Display**. The **ActiveSync Remote Display** window displays with the Voice Only WT41N0 desktop shown.



Figure 4-3 ActiveSync Remote Display Window

2. Use the host computer mouse to control the Voice Only WT41N0 desktop.
3. When finished, close the **ActiveSync Remote Display** window.

CHAPTER 5 WIRELESS APPLICATIONS

Introduction

Wireless Local Area Networks (LANs) allow mobile computers to communicate wirelessly and send captured data to a host device in real time. Before using the WT41N0 on a WLAN, the facility must be set up with the required hardware to run the wireless LAN and the WT41N0 must be configured. Refer to the documentation provided with the access points (APs) for instructions on setting up the hardware.

✓ **NOTE** 802.11d is enabled by default. When enabled, the AP must be configured the same in order to connect.

To configure the WT41N0, a set of wireless applications provide the tools to configure and test the wireless radio in the WT41N0. Refer to the *Wireless Fusion Enterprise Mobility Suite User Guide for Version X2.00* for information on configuring wireless profiles. Go to <http://www.zebra.com/support> for the latest version of this guide. See *Software Versions on page xii* to determine the Fusion version on the WT41N0.

Tap the **Signal Strength** icon to display the **Wireless Launcher** menu.

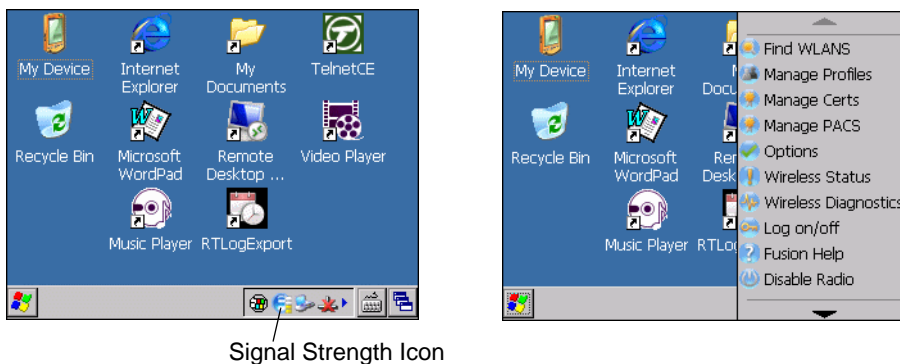

Figure 5-1 *Wireless Launcher Menu*

Many of the items in the menu invoke one of the Fusion applications. These menu items and their corresponding applications are summarized in [Table 5-1](#).

Table 5-1 *Supported Applications*

Application	Description
Find WLANs	Invokes the Find WLANs application which displays a list of the WLANs available in your area.
Manage Profiles	Invokes the Manage Profiles application (which includes the Profile Editor Wizard) to manage and edit your list of WLAN profiles.
Manage Certs	Invokes the Certificate Manager application which allows you to manage certificates used for authentication.
Manage PACs	Invokes the PAC Manager application which helps you manage the list of Protected Access Credentials used with EAP-FAST authentication.
Options	Invokes the Options application which allows you to configure the Fusion option settings.
Wireless Status	Invokes the Wireless Status application which allows you to view the status of the current wireless connection.
Wireless Diagnostics	Invokes the Wireless Diagnostics application which provides tools with which to diagnose problems with the wireless connection.
Log On/Off	Invokes the Network Login dialog which allows you to log on to a particular profile or to log off from the currently active profile.

Additional **Wireless Launcher** menu entries include:

- Enable/Disable Radio
- Hide Menu
- Exit.

Signal Strength Icon

The **Signal Strength** icon in the task tray indicates the mobile computer's wireless signal strength as follows:

Table 5-2 *Signal Strength Icons Descriptions*







Icon	Status	Action
	Excellent signal strength	WLAN network is ready to use.
	Very good signal strength	WLAN network is ready to use.
	Good signal strength	WLAN network is ready to use.
	Fair signal strength	WLAN network is ready to use. Notify the network administrator that the signal strength is only "Fair".
	Poor signal strength	WLAN network is ready to use. Performance may not be optimum. Notify the network administrator that the signal strength is "Poor".

Table 5-2 *Signal Strength Icons Descriptions (Continued)*

Icon	Status	Action
	Out-of-network range (not associated)	No WLAN network connection. Notify the network administrator.
	The WLAN radio is disabled.	The WLAN radio is disabled. To enable, choose Enable Radio from the Wireless Applications menu.
None	The Wireless Launcher application was exited.	The Wireless Launcher application has been closed. See the Fusion Functions paragraphs below for how to restart the Wireless Launcher .

Turning the Radio On and Off

By default, the WLAN radio is on.

On a WT41N0 with Touch Screen

To turn off the WLAN radio, tap the **Signal Strength** icon in the task tray and select **Disable Radio**.



Signal Strength Icon

Figure 5-2 *Signal Strength Icon*

To turn the radio on, tap the **Signal Strength** icon in the task tray and select **Enable Radio**.

On a WT41N0 with Non-touch Screen

To turn off the WLAN radio:

1. Press **ALT > W**. The Fusion menu appears.
2. Use the navigation keys to select **Disable Radio**.
3. Press **ENTER**.

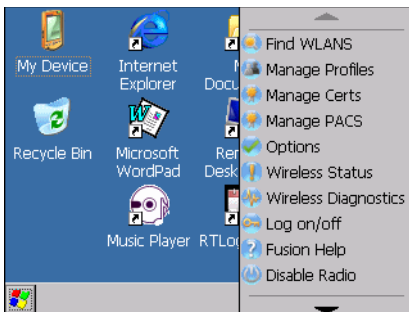

Figure 5-3 *Fusion Menu*

To turn on the WLAN radio:

1. Press **ALT > W**.

2. Use the navigation keys to select **Enable Radio**.
3. Press **ENTER**.

Minimum Setup

Below is a list of the minimum effort to achieve a wireless connection. Note that there are many discrete nuances that may affect the performance of your wireless connection that might be missed if you do not consider them carefully.

You will need to create a profile. It is recommended that you read the profile editor chapter.

1. Find out from your IT administrator what the connection settings should be (Extended Service Set Identifier (ESSID), Enterprise or Personal, authentication type, tunnel type, certificate requirements, Protected Access Credentials (PAC) requirements). Note that not all of the items listed may be relevant.
2. Create the profile using the information provided by the IT administrator.
3. Enter the **Manage Profile** screen, select the profile (press and hold), and select the **Connect** option in the context menu that appears.

CHAPTER 6 BLUETOOTH

Introduction

✓ **NOTE** The Voice Only WT41N0 requires the use of a Remote Desktop software to configure settings and software. See *Voice Only WT41N0 Remote Control on page 4-1* for information on setting up the device with remote desktop software.

Bluetooth-equipped devices can communicate without wires, using frequency-hopping spread spectrum (FHSS) RF to transmit and receive data in the 2.4 GHz Industry Scientific and Medical (ISM) band (802.15.1). Bluetooth wireless technology is specifically designed for short-range (30 feet/10 meters) communications and low power consumption.

Wearable terminals with Bluetooth capabilities can exchange information (e.g., files, appointments and tasks) with other Bluetooth enabled devices such as headsets, printers, access points and other wearable terminals.

Zebra wearable terminals with Bluetooth technology use the StoneStreet One Bluetooth stack. To program Bluetooth within the wearable terminal refer to the StoneStreet One SDK, available at the Zebra Support Central web site on the WT4100 product page.

Adaptive Frequency Hopping

Adaptive Frequency Hopping (AFH) is a method of avoiding fixed frequency interferers. AFH can be used with Bluetooth voice. All devices in the piconet (Bluetooth network) must be AFH-capable in order for AFH to work. There is no AFH when connecting and discovering devices. Avoid making Bluetooth connections and discoveries during critical 802.11b communications. AFH for Bluetooth can be broken-down into four main sections:

- Channel Classification - A method of detecting an interference on a channel-by-channel basis, or pre-defined channel mask.
- Link Management - Coordinates and distributes the AFH information to the rest of the Bluetooth network.
- Hop Sequence Modification - Avoids the interference by selectively reducing the number of hopping channels.
- Channel Maintenance - A method for periodically re-evaluating the channels.

When AFH is enabled, the Bluetooth radio “hops-around” (instead of through) the 802.11b high-rate channels. AFH coexistence allows Zebra wearable terminals to operate in any infrastructure. AFH is always enabled in the wearable terminal.

The Bluetooth radio in this wearable terminal operates as a Class 2 device power class. The maximum output power is 2.5mW and the expected range is up to 32.8 feet (10 meters). A definitive definition of ranges based on power class is difficult to obtain due to power and device differences, and whether one measures open space or closed office space.

✓ **NOTE** It is not recommended to perform Bluetooth wireless technology inquiry when high rate 802.11b operation is required.

Security

The current Bluetooth specification defines security at the link level. Application-level security is not specified. This allows application developers to define security mechanisms tailored to their specific need. Link-level security is really between devices not users, while application-level security can be implemented on a per-user basis. The Bluetooth specification defines security algorithms and procedures needed to authenticate devices, and if needed, encrypt the data flowing on the link between the devices. Device authentication is a mandatory feature of Bluetooth while link encryption is optional.

Pairing of Bluetooth devices is accomplished by creating an initialization key that is used to authenticate the devices and create a link key for them. Entering a common PIN number in the devices being paired generates the initialization key. The PIN number is never sent over the air. By default, the Bluetooth stack responds with no key when a key is requested (it is up to user to respond to the key request event). Authentication of Bluetooth devices is based-upon a challenge-response transaction. Bluetooth allows for a PIN number or passkey that is used to create other 128-bit keys used for security and encryption. The encryption key is derived from the link key used to authenticate the pairing devices. Also worthy of note is the limited range and fast frequency hopping of the Bluetooth radios that makes long-distance eavesdropping difficult.

It is recommended:

- Perform pairing in a secure environment
- Keep PIN codes private and don't store the PIN codes in the wearable terminal
- Implement application-level security.

Security Mode 3 (Link Level Encryption)

The wearable terminal supports Security Level 3 (Link Level Encryption). Link level encryption is the data security process of encrypting information at the data link level as it is transmitted between two devices.

Microsoft Bluetooth Stack

When pairing with a remote device using the Microsoft Bluetooth UI, Security Level 3 (Link Level Encryption) is automatically used. When developing applications using the Microsoft Bluetooth stack, enable Security Mode 3 using the *BthSetEncryption* API call. Refer to the Microsoft MSDN for more information.

StoneStreet One Bluetooth Stack

To set Security Mode 3 on outgoing serial port connections, set **Encrypt Link On All Outgoing Connections** checkbox in the **Settings > Security**. See *Security on page 6-2* for more information.

FIPS 140-2

The WT41N0 supports FIPS 140-2 for Bluetooth using the Microsoft Bluetooth stack and the StoneStreet One Bluetooth stack. FIPS provides secure Bluetooth communication between the WT41N0 and another mobile computer or scanner only using a Serial Port Profile.

Bluetooth Configuration

By default the wearable terminal is configured to use the StoneStreet One Bluetooth stack. [Table 6-1](#) lists the services supported by the StoneStreet One Bluetooth stack and the Microsoft Bluetooth stack.

Table 6-1 *Bluetooth Services*

Features	Microsoft Bluetooth Stack	StoneStreet One Bluetooth Stack
GAP Profile	Yes	Yes
SDP Profile	Yes	Yes
Serial Port Profile (Server and Client)	Yes	Yes
Headset Profile (Audio Gateway)	Yes	Yes
Dialup Networking Profile (Client Role)	No	Yes
Generic OBEX push Profile	No	Yes
File Transfer Profile (Server Role)	No	Yes
File Transfer Profile (Client Role)	No	Yes
HID Profile	No	Yes

[Table 6-2](#) lists the COM ports available for the StoneStreet One and Microsoft Bluetooth stacks.

Table 6-2 *COM Ports*

Microsoft Bluetooth Stack	StoneStreet One Bluetooth Stack
COM5	COM5
COM9	COM9
	COM11
	COM21
	COM22
	COM23

Bluetooth Power States

Cold Boot

When a cold boot is performed on the wearable terminal, Bluetooth turns off. It is normal to see the **Bluetooth** icon appear and disappear, as well as a wait cursor, when initialization proceeds in all modes.

Warm Boot

When a warm boot is performed on the wearable terminal, Bluetooth returns to the previous state.

Suspend

When the wearable terminal suspends, Bluetooth turns off.

- ✓ **NOTE** When the wearable terminal is placed in suspend mode, the Bluetooth radio mode powers off and the piconet (Bluetooth connection) is dropped. When the wearable terminal resumes, it could take up to 10 seconds for the Bluetooth radio driver to re-initialize the radio.

Resume

When the wearable terminal resumes, Bluetooth turns on if it was on prior to suspend. Note that any Bluetooth connection that was dropped during a suspend needs to be reconnected after a resume.

MotoBTUI Application

Use the MotoBTUI application to:

- Turn the Bluetooth radio on and off.
- View device information
- Control device status
- Generate a pairing bar code (Refer to the *RS507 Product Reference Guide* for more information).
- Configure FIPS key
- Discover and pair with other Bluetooth devices (using the Microsoft stack).



Stone Street One Stack



Microsoft Stack

Figure 6-1 MotoBTUI Window

Device Information

To view the WT41N0 Bluetooth information:

1. Tap **Start > Programs > MotoUI**.
2. Tap **My Device Information**.
3. The **Device Information** window displays:
 - Device Name
 - HCI version number
 - LMP version number
 - Bluetooth chip manufacturer name
 - BT UI version number.
4. Tap the Back button to return to the **MotoBTUI** window.

FIPS Configuration

- ✓ **NOTE** By default the WT41N0 has a FIPS key installed. If required, the user can generate a new FIPS key. If a new key is generated on the WT41N0, the same key is required to be used on the other Bluetooth device. The user must transfer the key to the other device.

To generate a new FIPS key automatically:

1. Tap **Start > Programs > MotoUI**.
2. Tap **FIPS Configuration**.
3. Tap **Generate Key** button.
4. Tap the **SetUp Key** button. A new key is generated. The key file, NewAESKey.reg, is created in the */Application* folder.
5. Tap the Back button to return to the **MotoBTUI** window.

To generate a new FIPS key manually:

1. Tap **Start > Programs > MotoUI**.
2. Tap **FIPS Configuration**.
3. Tap **Enter Key** button.
4. In the text box, enter a key.
5. Tap the **SetUp Key** button. A new key is generated. The key file, NewAESKey.reg, is created in the */Application* folder.
6. Tap the Back button to return to the **MotoBTUI** window.

To transfer the new FIPS key to another Bluetooth device:

1. Copy the NewAESKey.reg file from the WT41N0 to the other Bluetooth device. Place the file into the */Application* folder.
2. Navigate to the */Application* folder.

3. Locate the NewAESKey.reg file and tap the filename. The **RegMerge** confirmation box displays.
4. Tap **Yes**.
5. Perform a warm boot.

Device Status

Use the Device Status option to set if the WT41N0 would be seen by other Bluetooth devices. Select the **Device Status** option to toggle the WT41N0 from Hidden to Discoverable.

Using the StoneStreet One Bluetooth Stack

The BTEplorer application can be accessed from the App Launcher menu or by a key combination.

Turning the Bluetooth Radio Mode On and Off

Turn off the Bluetooth radio to save power or if entering an area with radio restrictions (e.g., an airplane). When the radio is off, the wearable terminal can not be seen by or connected to other Bluetooth devices. Turn on the Bluetooth radio to exchange information with other Bluetooth devices (within range). Communicate only with Bluetooth radios in close proximity.

✓ **NOTE** To achieve the best battery life in wearable terminals with multiple radios, turn off the radios that are not being used.

Disabling Bluetooth

To disable Bluetooth, press **ALT - B**. Use the navigation keys to select **Disable Bluetooth**. Press **ENTER**. An exclamation point appears on the Bluetooth icon indicating that the Bluetooth radio is disabled.

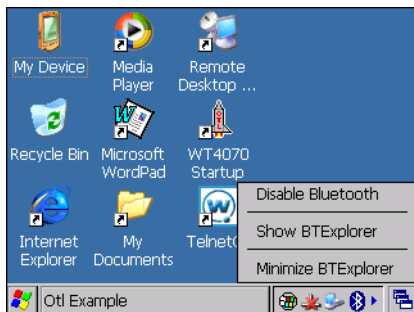

Figure 6-2 *Disable Bluetooth*

Enabling Bluetooth

To enable Bluetooth, press **ALT - B**. Use the navigation keys to select **Enable Bluetooth**. Press **ENTER**. The **Bluetooth** icon changes to indicate that Bluetooth is enabled.

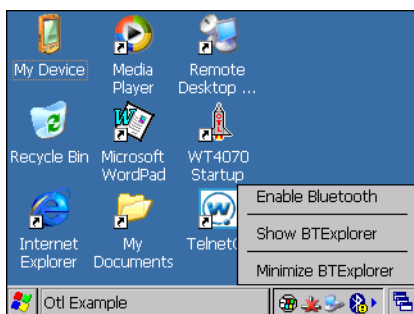

Figure 6-3 *Enable Bluetooth*

Using App Launcher

✓ **NOTE** App Launcher is not available on the Voice Only WT41N0.

In the **App Launcher** main menu, press **4** to select **Utilities**. Press **3** to select **BT Explorer**.

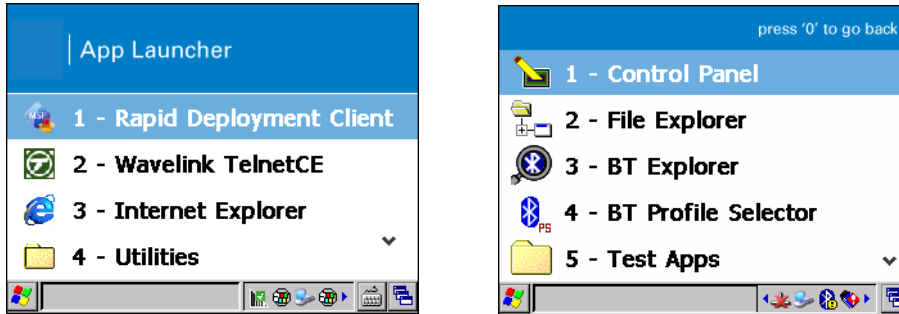

Figure 6-4 App Launcher Screens

Using Key Combination

Press **ALT - B**. Use the navigation keys to select **Show BTEplorer**.

Using Screen Touch

Touch the Bluetooth icon in the task tray and select **Show BTEplorer**.

BTEplorer Non-touch Display Navigation

The WT41N0 with non-touch display is a key-based device and navigation within the BTEplorer application is performed using the keypad.

Table 6-3 Function Keys

Action Key	Key Combination
ALT	Blue key - CTRL
MENU	Blue key - TAB
SPACE	Blue key - BKSP
Left arrow	Blue key - up arrow
Right arrow	Blue key - down arrow

Refer to the *WT41N0 User Guide* for detailed information on keypad navigation.

Key Combinations

The wearable terminal with non-touch display uses special key combinations to easily navigate applications. [Table 6-4](#) lists the key combinations required to perform various application navigation and control functions.

Table 6-4 Key Combinations

Action	Combination
Access the Start menu on the taskbar	CTRL - ESC
Switch fields within an application	TAB
Close windows or cancel operations on some applications	ESC or ALT - F4
Access the Task Manager	ALT - TAB
Switches to the next window or desktop	ALT - ESC
Access a menu bar in an application	ALT - CTRL
Press a button or select a check box in an application	TAB until the item is highlighted then SPACE.
Display a pop-up context menu	MENU
	CTRL - TAB

Discovering Bluetooth Device(s)

The wearable terminal can receive information from discovered devices, without pairing. However, once paired, an exchange of information between the wearable terminal and a paired device occurs automatically when the Bluetooth radio is turned on.

To find Bluetooth devices in the area:

1. Ensure that Bluetooth is enabled on both devices.
2. Ensure that the Bluetooth device being looked for is in discoverable and connectable mode.
3. Ensure that the required profile is enabled on the WT41N0. See *Profiles* on page 6-29 for more information.
4. Ensure that the two devices are within 30 feet (10 meters) of one another.
5. Access BTE Explorer. See *Using the StoneStreet One Bluetooth Stack* on page 6-7.

✓ **NOTE** If favorite connections have already been created, the **Favorites** screen displays. If no favorite connections have been created, the **New Connection Wizard** screen displays.

6. From the **Favorite** window:
 - a. Press **ALT - F** to open the **File** menu.
 - b. Use the navigation keys to select **New Connection** and press **ENTER**. The **New Connection Wizard** window appears.



Figure 6-5 *New Connection Wizard Window*

7. Use the navigation keys to select **Explore Services on Remote Device**.

The following actions are available in the drop-down list (actions may vary depending upon configurations):

- Explore Services on Remote Device
- Pair with a Remote Device
- Active Sync via Bluetooth
- Browse Files on Remote Device
- Connect to Headset
- Connect to Internet using Access Point
- Connect to Internet using Phone/Modem
- Connect to Personal Area Network
- Connect to Printer
- Send or Exchange Objects
- Associate Serial Port.

✓ **NOTE** If a device discovery action has not been previously performed, a device discovery is automatically initiated. If a device discovery has previously been performed, the device discovery process is skipped, and the previously found list of devices displays. To start a new device discovery, press **Menu** select **Discover Devices** from the menu and press **ENTER**.

8. Press **ENTER**. **BTExplorer** searches for Bluetooth devices in the area and displays the devices in the **Select Remote Device** window.



Figure 6-6 *Device Discovery Dialog Box*

- ✓ **NOTE** To filter devices in the list press **ALT - F** to open the filter menu. Select a device type and then press **ENTER**.

To change the display view press **ALT - V** to open the view menu. Select a view type and then press **ENTER**.

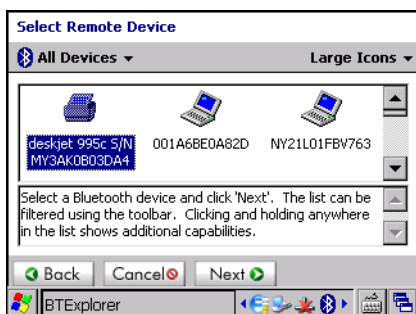

Figure 6-7 Select Remote Device Window

9. Use the navigation keys to select a device from the list and press **ENTER**. The wearable terminal searches for services on the selected Bluetooth device.

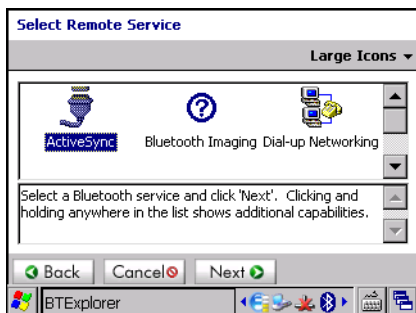

Figure 6-8 Device Services

10. Use the navigation keys to select a service from list and press **ENTER**. The **Connection Favorite Options** window appears.

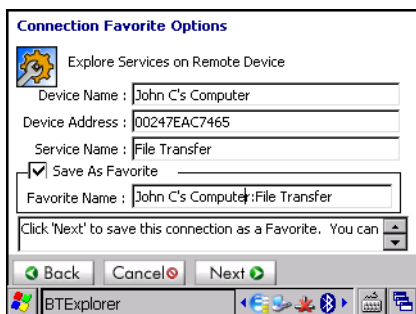

Figure 6-9 Connection Favorite Options Window

11. Press **TAB** to highlight the **Favorite Name** text box, enter a name for this service that will appear in the **Favorite** window.
12. Press **ENTER**. The **Connection Summary** window appears.

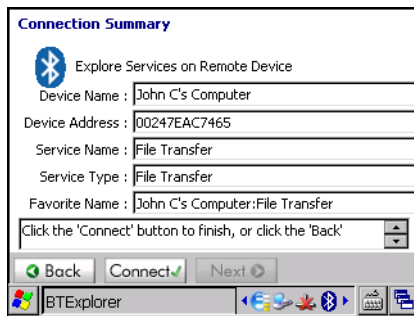

Figure 6-10 Connection Summary Window

13. Press **P2** to add the service to the **Favorite** window.

14. The **Favorite** window appears and the wearable terminal connects to the remote device.

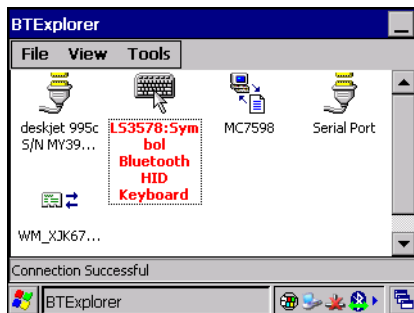

Figure 6-11 Favorite Window with Active Connection

Available Services

Some examples of available services are:

- File Transfer Services
- Headset Services
- OBEX Object Push Services
- Serial Port Services
- Personal Area Network Services
- HID Services.

These services are discussed in the following paragraphs.

File Transfer Services

✓ **NOTE** Shared folders are a security risk.

To transfer files between the wearable terminal and another Bluetooth enabled device:

1. In the **Favorite** window, use the navigation keys to select the file transfer service.
2. Press **MENU** and select **Connect** from the pop-up menu.
3. Press **ENTER**. The **File Transfer** window appears listing the folders of the remote device.



Figure 6-12 File Transfer Window

4. Use the navigation keys to select a file. To open a folder press **ENTER**.
5. Press **ENTER** to copy the file from the remote device. The **Save Remote Device** window appears.

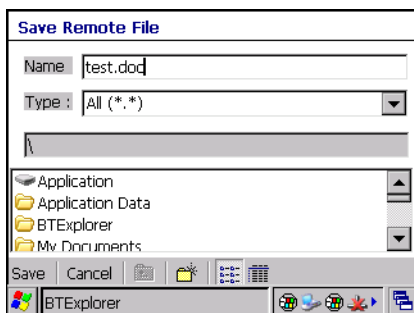

Figure 6-13 Save Remote File Window

6. Press **TAB** three times to enter the folder area.
7. Use the navigation keys to select a folder to place the file into.
8. Press **ENTER**.
9. Press **ENTER** to save the file.
10. Select the action to perform:
 - a. **New** - create a new file or folder on the remote device.
 - b. **Delete** - delete the selected file on the remote device.
 - c. **Get File** - copy the file from the remote device to the wearable terminal.
 - d. **Put File** - copies a file from the wearable terminal to the remote device.
 - e. **Parent Directory** - opens the higher level folder.
 - f. **Refresh** - re-displays the files in the current folder.

Create New File or Folder

To create a new folder or file on the remote device:

1. Press **MENU** to open the pop-up menu.
2. Use the navigation keys to select **New**.
3. Press the right arrow to open the sub-menu.
4. Use the navigation keys to select **Folder** or **File**.

5. Press **ENTER**. The **Create New Folder** or **Create New File** window appears.

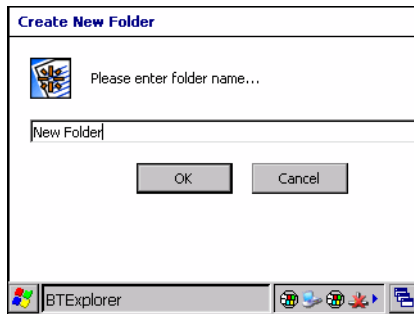

Figure 6-14 Create New Folder Window

6. Enter a new name for the new folder or file and then press **ENTER**.
7. A new folder or file is created on the remote device.

Delete File

To delete a file from the remote device:

1. Use the navigation keys to select the file to delete.
2. Press **MENU** to open the pop-up menu.
3. Use the navigation keys to select **Delete**.
4. Press **ENTER**. A **Delete Remote Device File** dialog box appears.
5. Press **ENTER** to delete the file.

Get File

To copy a file from a remote device to the wearable terminal:

1. Press **MENU** to open the pop-up menu.
2. Use the navigation keys to select **Get File**.
3. Press **ENTER**. The **Save Remote File** window appears.

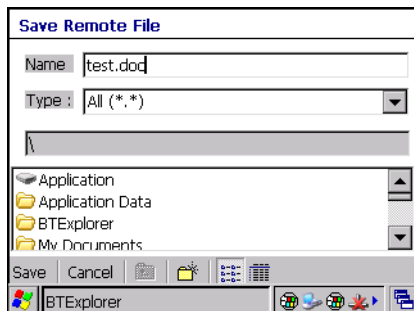

Figure 6-15 Save Remote File Window

4. Press **TAB** three times to enter the folder area.
5. Using the navigation keys to highlight a folder and press **ENTER**. The **OBEX Object Push** window appears.
6. Press **ENTER**. The file is transferred from the remote device to the wearable terminal.

Put File

To copy a file from the wearable terminal to a remote device:

1. In the **File Transfer** window, navigate to a folder where the file will be put into.
2. Press **MENU** to open the pop-up menu.
3. Use the navigation keys to select **Put File**.
4. Press **ENTER**. The **Send Local File** window appears.

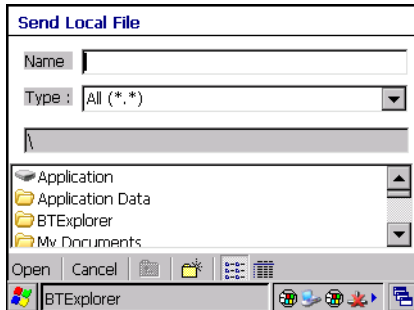

Figure 6-16 Send Local File Window

5. Press **TAB** three times to enter the folder area.
6. Select a file in the wearable terminal.
7. Press **ENTER**. The **Sending Local File** window appears.

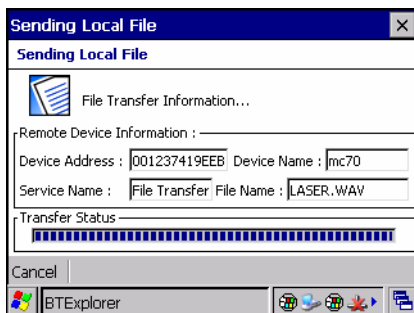

Figure 6-17 Sending Local File Window

8. The file is transferred from the wearable terminal to the remote device.

Connect to Internet Using Access Point

This section explains how to access a Bluetooth-enabled LAN access point (AP) for a network connection. With this method of communication the Internet Explorer can be used to connect to a server.

1. In the **Favorite** window, use the navigation keys to select the LAN Access service.
2. Press **MENU** and select **Connect** from the pop-up menu.
3. Press **ENTER**.
4. The wearable terminal connects with the Access Point.
5. Press **CTRL - ESC** to open the **Start** menu.
6. Use the navigation keys to select **Internet Explorer**.

7. Press **ENTER**. The **Internet Explorer** window appears.
8. In the address field, enter an internet address and tap the **Enter** button. The web page loads.

OBEX Object Push Services

Object Exchange (OBEX) is a set of protocols allowing pictures to be shared using Bluetooth. To send a picture to another device:

1. In the **Favorite** window, use the navigation keys to select the OBEX Push service.
2. Press **MENU** and select **Connect** from the pop-up menu.
3. Press **ENTER**. The **OBEX Object Push** window appears.

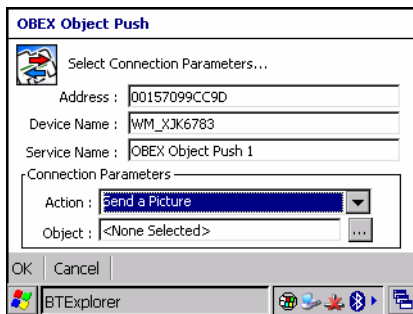



Figure 6-18 OBEX Object Push Window

4. Press **TAB** twice to highlight the  button.
5. Press **SPACE**.
6. The **Send Local Picture** window appears.

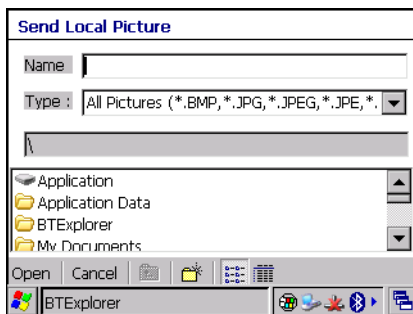

Figure 6-19 Send Local Picture Window

7. Press **TAB** three times to enter the folder area.
8. Using the navigation keys to highlight a file and press **ENTER**. The **OBEX Object Push** window appears. To open a folder, highlight the folder and press **ENTER**.
9. Press **ENTER**. The wearable terminal connects to the remote device and begins to send the file. The **Sending Picture** window appears. When the file transfer is complete a confirmation dialog appears. Press **ENTER**.

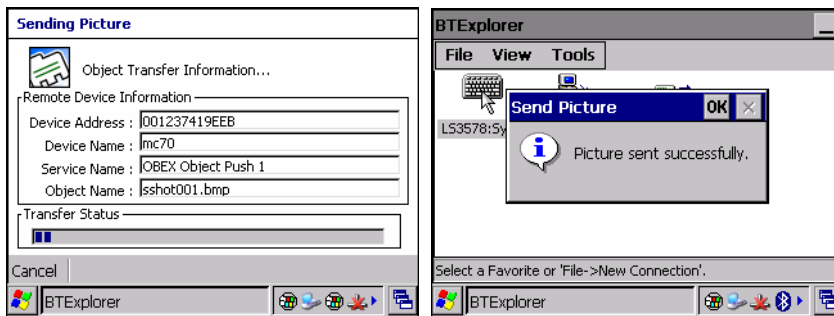

Figure 6-20 *Sending Picture Window*

Headset Services

To connect to a Bluetooth headset:

1. In the **Favorite** window, use the navigation keys to select the headset service.
2. Press **MENU** and select **Connect** from the pop-up menu.
3. Press **ENTER**.
4. The wearable terminal connects to the headset. Refer to your headset user manual for instruction on communicating with a Bluetooth device.

Serial Port Services

- ✓ **NOTE** By default, COM ports COM4, COM5 and COM9 are Bluetooth virtual ports. If an application opens one of these ports, the Bluetooth driver activates and guides you through a Bluetooth connection.

Use the wireless Bluetooth serial port connection just as you would a physical serial cable connection. You must configure the application that will use the connection to the correct serial port.

To establish a serial port connection:

1. In the **Favorite** window, use the navigation keys to select the Serial Port service.
2. Press **MENU** and select **Connect** from the pop-up menu.
3. Press **ENTER**.
4. The **Remote Service Connection** window appears.

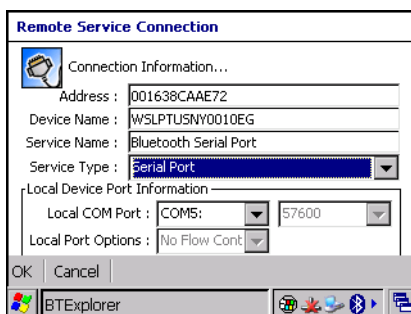

Figure 6-21 *Remote Service Connection Window*

5. In the **Local COM Port** drop-down list select a COM port.
6. Press **ENTER**.

Personal Area Network Services

Connect two or more Bluetooth devices to share files and collaborate.

To establish a Personal Area Network connection:

1. In the **Favorite** window, use the navigation keys to select the Personal Area Network service.
2. Press **MENU** and select **Connect** from the pop-up menu.
3. The wearable terminal connects to the Personal Area Network.

HID Services

Connect input devices such as Bluetooth keyboards and mice to the wearable terminal.

To establish a HID connection:

1. In the **Favorite** window, use the navigation keys to select the HID service.
2. Press **MENU** and select **Connect** from the pop-up menu.
3. The wearable terminal connects to the HID device.

Bonding with Discovered Device(s)

A bond is a relationship created between the wearable terminal and another Bluetooth device in order to exchange information in a secure manner. Creating a bond involves entering the same PIN on the two devices to bond. Once a bond is created, and the Bluetooth radios are turned on, the devices recognize the bond and are able to exchange information without re-entering a PIN.

To bond with a discovered Bluetooth device:

✓ **NOTE** If favorite connections have already been created, the **Favorites** screen displays. If no favorite connections have been created, the **New Connection Wizard** screen displays.

1. Access BTE Explorer. See *Using the StoneStreet One Bluetooth Stack on page 6-7*.
2. Press **ALT - F** to open the **File** menu.
3. Use the navigation keys to select **New Connection** and press **ENTER**. The **New Connection Wizard** window appears.

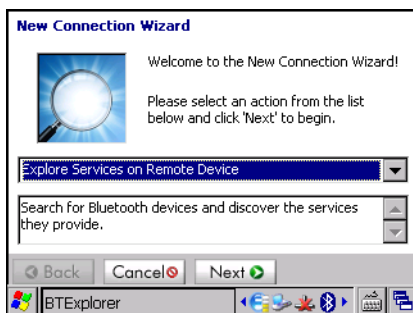

Figure 6-22 *New Connection Wizard Window*

4. Use the navigation keys to select **Pair with Remote Device**.
5. Press **ENTER**. The **BTE Explorer** searches for Bluetooth devices in the area and displays the devices in the **Select Remote Device** window.

- ✓ **NOTE** Devices discovered previously are listed to save time. To start a new device discovery, press **Menu** select **Discover Devices** from the menu and press **ENTER**.

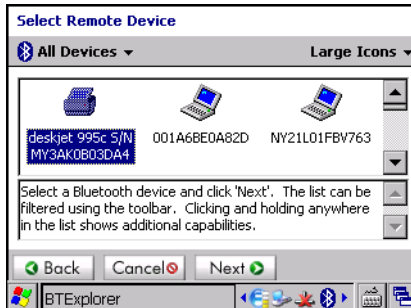

Figure 6-23 Select Remote Device Window

- ✓ **NOTE** To filter devices in the list press **ALT - F** to open the filter menu. Select a device type and then press **ENTER**.

To change the display view press **ALT - V** to open the view menu. Select a view type and then press **ENTER**.

6. Use the arrow keys to select a device from the list and press **ENTER**. The **PIN Code Request** window appears.

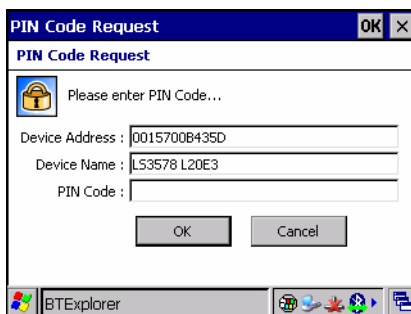

Figure 6-24 Connection Favorite Options Window

7. In the **PIN Code** field, enter the PIN code.
8. Press **ENTER**. The **Pairing Status** window displays.



Figure 6-25 Pairing Status Window

9. Press **P2**. The devices are successfully paired. The device name moves to the **Trusted Devices** window.

Accepting a Bond

When a remote device wants to bond with a wearable terminal, you give permission by entering a PIN when requested.

1. Ensure that the wearable terminal is set to discoverable and connectable. See *Bluetooth Settings on page 6-23*.
2. When prompted to bond with the remote device the **PIN Code Request** window appears.



Figure 6-26 PIN Code Request Window

✓ **NOTE** Connections to untrusted devices are a security risk.

3. In the **PIN Code:** text box, enter the same PIN that was entered on the device requesting the bond. The PIN must be between 1 and 16 characters.
4. Press **ENTER**. The bond is created and the wearable terminal can now exchange information with the other device.

Trusted Devices Window

The **Trusted Devices** window lists all bonded devices. To access the **Trusted Devices** window:

1. Launch **BTE Explorer**.
2. Press **ALT - T**.
3. Using the navigation keys select **Trusted Devices**.
4. Press **ENTER**. The Trusted Devices window appears.



Figure 6-27 Trusted Device Window

The **Trusted Devices** window contains one menu that can be accessed through key combinations. It allows you to change the window listing. To open the **View** menu press **ALT - V**. The menu drop-down list appears.

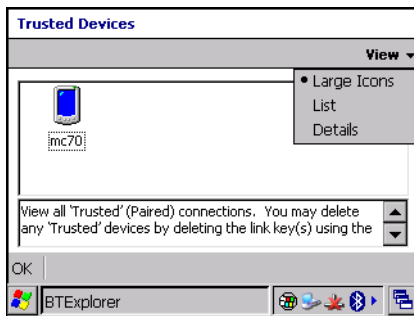

Figure 6-28 *Trusted devices Window Menu*

Use the navigation keys to select a view type and then press **ENTER**.

Deleting a Bonded Device

If it is no longer necessary to connect with a device, delete it from the **Bluetooth Trusted Devices** window.

1. Use the navigation keys to select a device.
2. Press **MENU**.
3. Use the navigation keys to select **Delete Link Key**.
4. Press **ENTER**. A confirmation dialog box appears.
5. Press **ENTER** to confirm deletion of the trusted device.
6. Press **ENTER** to exit the **Trusted Device** window.

Connecting to a Favorite Service

The **Favorite** window can display many services set as favorites. To connect to one of these services:

1. Use the navigation keys to select the service.
2. Press **ENTER**.
3. The wearable computer connects to the service. The service icon text becomes highlighted.

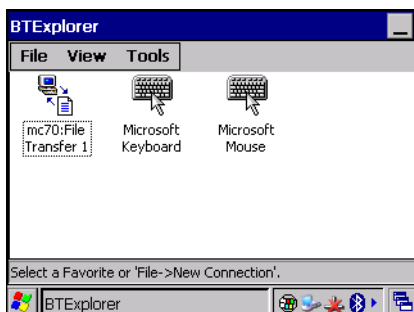

Figure 6-29 *Favorite Window*

To disconnect from a connected service:

1. Use the navigation keys to select the highlighted service.
2. Press **MENU**.
3. Use the navigation keys to select **Disconnect**.

4. Press **ENTER**. A deaconate confirmation dialog box appears.
5. Select **Yes** to disconnect the service. The wearable computer disconnects from the service.

Navigating the Favorites Window

The **Favorites** window has three menus that can be accessed through key combinations.

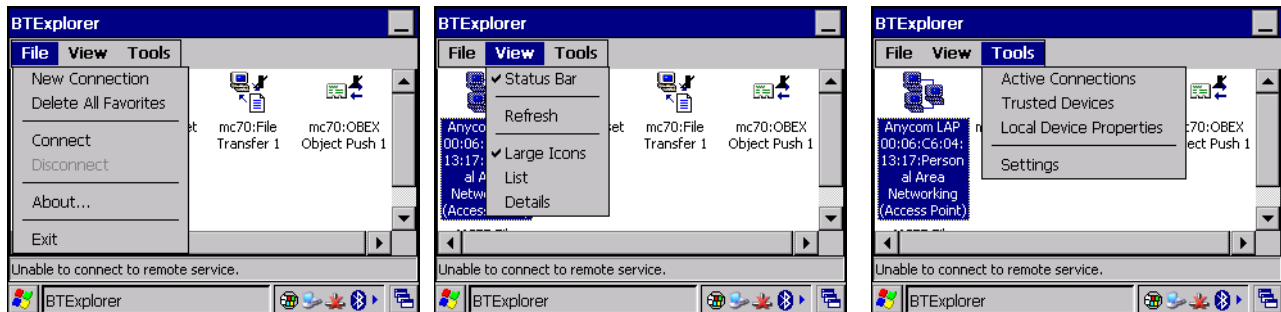

Figure 6-30 Favorites Window Menus

To open the **File** menu, press **ALT - F**.

To open the **View** menu, press **ALT - V**.

To open the **Tools** menu, press **ALT - T**.

Delete all Favorite Services

To delete all favorites from the **Favorites** window:

1. Press **ALT - F**.
2. Use the navigation keys to select **Delete All Favorites**.
3. Press **ENTER**. A confirmation dialog box appears.
4. Press **ENTER** to confirm the deletion or **ESC** to cancel the deletion.

Delete a Favorite Service

To delete a selected favorite:

1. Use the navigation keys to select a favorite.
2. Press **MENU**. The pop-up menu appears.
3. Use the down arrow key to select **Delete**.
4. Press **ENTER**. A confirmation dialog box appears.
5. Press **ENTER** to confirm the deletion or **ESC** to cancel the deletion.

Rename a Favorite Service

To rename a favorite:

1. Use the navigation keys to select a favorite.
2. Press **MENU**.

3. Use the down arrow key to select **Rename**.
4. Press **ENTER**. The **Change Device Name** window appears.
5. Enter a new name.
6. Press **ENTER** to change the name or **ESC** to cancel the name change.

Change the Display View

To change the display view:

1. Press **ALT - V**.
2. Use the down arrow key to select **Large Icons**, **List** or **Details**.
3. Press **ENTER**. The **Favorite** window layout changes.

View Active Connections

To view active connections:

1. Press **ALT - T**.
2. Use the down arrow key to select **Active Connections**.
3. Press **ENTER**. The **Active Connections** window appears.



NOTE To filter devices in the list press **ALT - F** to open the filter menu. Select a device type and then press **ENTER**.

To change the display view press **ALT - V** to open the view menu. Select a view type and then press **ENTER**.

4. Press **ENTER** to close the window.

View Properties

To view the properties of the wearable terminal:

1. Press **ALT - T**.
2. Use the down arrow key to select **Local Device Properties**.
3. Press **ENTER**. The **Local Device Property** window appears.
4. Press **ENTER** to close the window.

Bluetooth Settings

Use the **BTE Explorer Settings** window to configure the operation of the **BTE Explorer** application. To access the settings, press **ALT - T**, use the navigation keys to select **Settings**. Press **ENTER**. The **BTE Explorer Settings** window appears.

Use the left and right arrows to move from one tab to the next. Within a tab, use the **TAB** key to move from one field to the next.

Device Info Tab

Use the **Device Info** tab to configure the wearable terminal's Bluetooth connection modes.

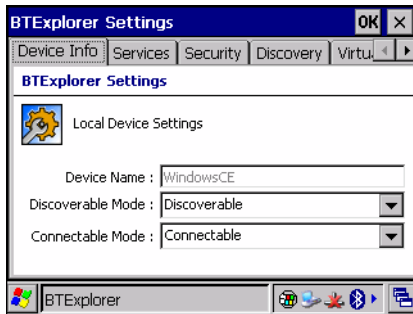

Figure 6-31 BTE Explorer Settings - Device Info Tab

Press **TAB** to move to the next field.

Table 6-5 Device Info Tab

Field	Description
Device Name	Displays the name of the wearable terminal. Not editable.
Discoverable Mode	Allows you to set the wearable terminal to be discoverable by other Bluetooth devices or not be discoverable. Note: For security reasons, the default is set to Non Discoverable .
Connectable Mode	Allows you to set the wearable terminal to be connectable by other Bluetooth devices or not be connectable. Note: For security reasons, the default is set to Non Connectable .

Services Tab

✓ **NOTE** For security reason, by default services are not enabled.

Use the **Services** tab to management of the services the wearable terminal makes available for use by other Bluetooth devices.

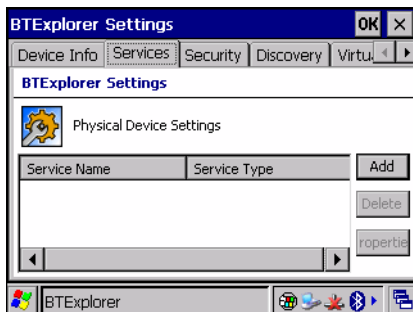

Figure 6-32 BTE Explorer Settings - Services Tab

To add a service:

1. Press **TAB** to highlight the **Add** key. Press **SPACE**. The **Add Local Service** window displays.

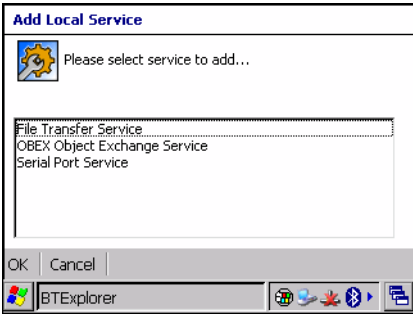

Figure 6-33 Add Local Service Window

2. In the list, use the navigation key to select a service to add.
3. Press **ENTER** to accept the service. Press **ESC** to exit without saving.
The **Edit Local Service** window displays for the selected service.
4. Select the appropriate information and then Press **ENTER**. See the following paragraphs for detailed information on the available services.

File Transfer Service

File transfer allows other Bluetooth devices to browse files.

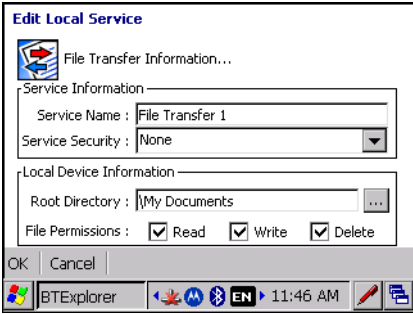

Figure 6-34 BTExplorer Settings - File Transfer Information

Table 6-6 File Transfer Information Data

Item	Description
Service Name	Displays the name of the service.
Service Security	Select the type of security from the drop-down list. Options are None , Authenticate , or Authenticate/Encrypt .
Root Directory	Select the directory that other Bluetooth devices can access.
File Permissions	Select the file permissions for the selected directory. Check the appropriate box to grant read access, write access, and delete access.

Headset Audio Gateway Service

Headset Service Audio Gateway allows connection to headset devices.

Table 6-7 *Headset Audio Gateway Data*

Item	Description
Service Name	Displays the name of the audio service.

OBEX Object Exchange Service

OBEX Object Exchange allows other Bluetooth devices to push contacts, business cards, pictures, appointments, and tasks to the WT41N0.

Table 6-8 *OBEX Exchange Information Data*

Item	Description
Service Name	Displays the name of the service.
Service Security	Select the type of security from the drop-down list. Options are None , Authenticate , or Authenticate/Encrypt .
Do not allow clients to push objects	Disables clients from pushing objects to the WT41N0.
Inbox Directory	Select a directory where another Bluetooth device can store files.
Business Card	Select Contact entry.

Personal Area Networking Service

Personal Area Networking hosts a Personal Area Network which allows communication with other Bluetooth devices.

Table 6-9 *Personal Area Networking Data*

Item	Description
Service Name	Displays the name of the service.
Service Security	Select the type of security from the drop-down list. Options are None , Authenticate , or Authenticate/Encrypt .
Support Group Ad-Hoc Networking	Select to enable Ad-Hoc networking.

Serial Port Service

Serial port allows other Bluetooth devices to access COM ports.

Table 6-10 Serial Port Services Data

Item	Description
Service Name	Displays the name of the service.
Service Security	Select the type of security from the drop-down list. Options are None , Authenticate , or Authenticate/Encrypt .
Local COM Port	Select the COM port.
Local Baud Rate	Select the communication baud rate.
Local Port Options	Select the port option.

Security

Security settings allows the user to set global security policies for Bluetooth. Note that these settings are only active on local Services that are set to Authenticate or Authenticate/Encryption. The user can set authentication on local Services under Services.

To adjust the security settings for an individual service, select **Services** first, then select the individual service, then **Properties**.

**Figure 6-35** BTE Explorer Settings - Security Tab

✓ **NOTE** To use PIN Code, select **Authenticate** or **Authenticate/Encrypt** from the Service Security drop-down list on each local service.

Table 6-11 Security Data

Item	Description
Use PIN Code (Incoming Connecting)	Select for automatic use of the PIN code entered in the PIN Code text box. It is recommended not to use this automatic PIN code feature. See <i>Security on page 6-2</i> for more information.
PIN Code	Enter the PIN code.
Encrypt Link On All Outgoing Connections	Select to enable or disable encryption on all outgoing connections to other Bluetooth devices.

Discovery Tab

Use the **Discovery** tab to set and modify discovered devices.

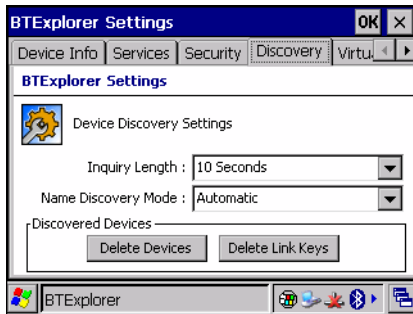

Figure 6-36 BTE Explorer Settings - Discovery Tab

Table 6-12 Discovery Data

Item	Description
Inquiry Length	Sets the amount of time the wearable terminal takes to discover Bluetooth devices in the area.
Name Discovery Mode	Select either Automatic or Manual to automatically attempt to discover a Bluetooth device's name after finding the device.
Discovered Devices - Delete Devices	Deletes all discovered devices and link keys from memory.
Discovered Devices - Delete Linked Keys	Removes all pairing from remote Bluetooth devices, and makes them all un-trusted.

Virtual COM Port Tab

Virtual COM Port defines which COM ports BTE Explorer attempts to use for virtual COM ports. Check the appropriate checkbox to use the port as a virtual COM port. When finished, choose **Apply** to enforce changes, or **Revert** to restore the original settings.

Table 6-13 Virtual COM Port Data

Item	Description
COM5:Bluetooth	Enable or disable COM Port 5.
COM9:Bluetooth	Enable or disable COM Port 9.
COM11:Bluetooth	Enable or disable COM Port 11.
COM21:Bluetooth	Enable or disable COM Port 21.
COM22:Bluetooth	Enable or disable COM Port 22.
COM23:Bluetooth	Enable or disable COM Port 23.

HID Tab

Use **HID** to select The Human Interface Device Profile programming interface that defines the protocols and procedures to be used to implement HID capabilities.

Provides support for devices such as mice, joysticks, keyboards.

Table 6-14 *HID Data*

Item	Description
Enable Key Repeat	Enables key repeat functionality.
Delay	To increase key repeat delay, drag the Delay slider to the right. To decrease key repeat delay, drag the Delay slider to the left.
Rate	To increase key repeat speed, drag the Rate slider to the left. To decrease key repeat speed, drag the Rate slider to the right.

Profiles

Use **Profiles** to load or remove Bluetooth service profiles. If a profile is not used, it can be removed to save memory.

1. Tap a check box next to the profile to load (activate). The serial Port profile is always active and cannot be removed.
2. Tap **Select All** to select all profiles or tap **Deselect All** to deselect all profiles.
3. Tap **Apply** to activate the profiles and then **Close** to exit the application.

System Parameters

Use **System Parameters** to set device connection settings.

Table 6-15 *HID Tab*

Item	Description
Page Timeout	Sets the amount of time the wearable terminal searches for a device before moving on to the next device.
Link Supervision Timeout	Sets the amount of time that the wearable terminal will wait for a device to come back into range after it has gone out of range. If the device does not come back into range by the set time, the wearable terminal drops the connection.

Miscellaneous Tab

Use the **Miscellaneous** tab to set color and types to better view active connections.

Table 6-16 *Miscellaneous Tab*

Item	Description
Highlight Connections	Select the connection type to highlight when connected. In the Wizard Mode, the only option is Favorites or None . In the Explorer mode the options are None , Tree View Only , List View Only or tree and List View .
Apply Text Style	Select the text style to be applied to the connection text.
Apply Text Color	Select the text color to be applied to the connection text.

Using the Microsoft Bluetooth Stack

The following sections provide information on using the Microsoft Bluetooth stack.

Power Modes

The Bluetooth radio switches between normal and low power modes automatically. When data transfer is required, the radio goes into normal mode. When there is no activity, the radio goes into low power mode.

Turning the Bluetooth Radio Mode On and Off

Turn off the Bluetooth radio to save power or if entering an area with radio restrictions (e.g., an airplane). When the radio is off, the wearable terminal can not be seen by or connected to other Bluetooth devices. Turn on the Bluetooth radio to exchange information with other Bluetooth devices (within range). Communicate only with Bluetooth radios in close proximity.



NOTE To achieve the best battery life in wearable terminals with multiple radios, turn off the radios that are not being used.

Disabling Bluetooth

To disable Bluetooth, select **Start > Settings > Control Panel > MotoBTUI** and then select **On** icon in the top left corner.

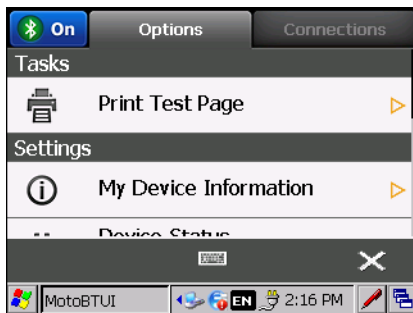

Figure 6-37 Disable Bluetooth

Enabling Bluetooth

To enable Bluetooth, select **Start > Settings > Control Panel > MotoBTUI** and then select **Off** icon in the top left corner.

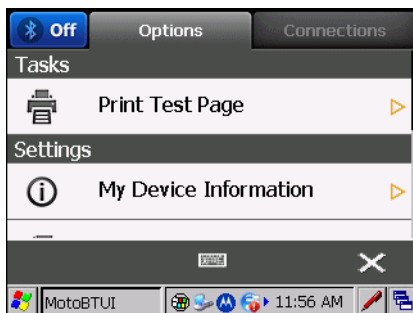

Figure 6-38 Enable Bluetooth

Discovering Bluetooth Device(s)

The wearable terminal can receive information from discovered devices without pairing. However, once paired, the wearable terminal and a paired device exchange information automatically when you turn the Bluetooth radio on.

To find Bluetooth devices in the area:

1. Ensure that Bluetooth is enabled on the device.
2. Ensure that the Bluetooth device to discover is in discoverable and connectable modes.
3. Ensure that the two devices are within 10 meters (32.8 feet) of one another.
4. Select **Start > Programs > MotoBTUI**.

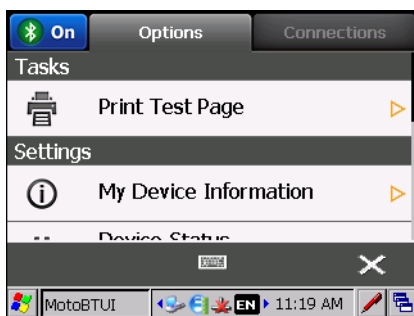

Figure 6-39 *MotoBTUI Window*

5. If Bluetooth is off, select the Bluetooth icon to turn Bluetooth on.
6. Select the **Connections** tab. The wearable terminal begins searching for discoverable Bluetooth devices in the area. Discovered devices appear in the list.

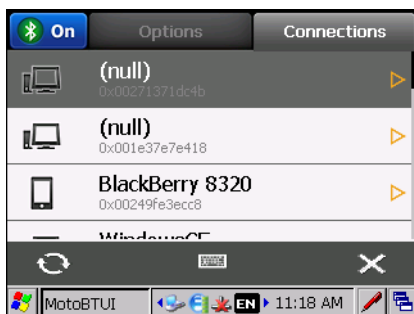

Figure 6-40 *Searching for Bluetooth Devices*

7. Use the navigation key to select a Bluetooth device.
8. Press **ENTER**. The **Services** window displays.

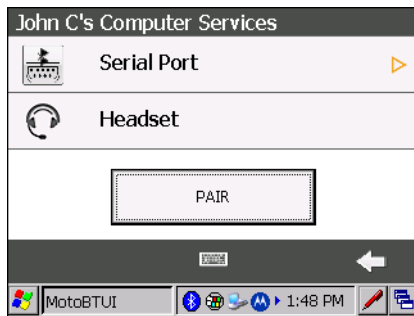

Figure 6-41 *Services Window*

9. Select Pair.

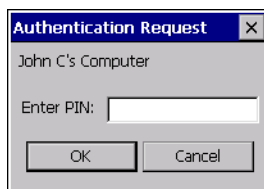

Figure 6-42 *Enter PIN*

10. Enter a PIN and then select **OK.**

11. On the Bluetooth device, enter the same PIN.

12. Enter the PIN on the other device. The device in the list become trusted (key icon).

You are prompted to enter a PIN. If the device has a specific PIN, enter it in the PIN field and tap Next. If the device does not have a specific passcode, enter one in the Passcode field and tap Next. The Bluetooth radio tries to connect with the device.

13. If you created a passcode, you will be prompted by the other device to enter the same passcode. Enter the created passcode to establish a paired connection. (If you entered a passcode from the device, you shouldn't have to do anything on the other device.)

14. When the connection is complete, a list of matching and supported services on the device appears.

15. Select the services you want to use and tap Finish. The services on the new devices have to be selected or else the pairing won't include those services, even though the devices are paired. If services are not selected, you will be continually re-prompted for the passcode from the device.

16. The device appears in the list on the main window.

After the passcodes have been accepted on both sides, you have a trusted ("paired") connection.

✓ **NOTE** Some devices might not require a PIN. This depends upon the device's authentication.

Available Services

✓ **NOTE** In order to connect to the Bluetooth device, the application must create the connection to the remote device. Please refer to the MSDN Help for detailed information.

The wearable terminal with Microsoft Bluetooth stack offers the Serial Port service and Headset service.

Bluetooth Printing

To print to a Bluetooth printer:

1. Download and install the Windows CE Printer Drivers for the wearable terminal from the Support Central web site.
2. Change the following registry entries of the desired printer (using a remote registry editor):
Key: HKEY_LOCAL_MACHINE\Drivers\BuiltIn\SymPrint
 - Set **TldDLL** to PrintTLDBluetooth.dll.
 - Modify **PrintPort** with appropriate COM port index value. (e.g.: **COM4: 19200**).
3. Tap **Start > Settings > Control Panel > MotoBTUI**.
4. If Bluetooth is off, select the Bluetooth icon to turn Bluetooth on.
5. Select the **Connections** tab. The wearable terminal begins searching for discoverable Bluetooth devices in the area. Discovered devices appear in the list.

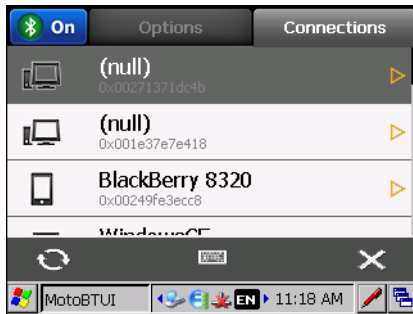

Figure 6-43 Searching for Bluetooth Devices

6. Use the navigation key to select a Bluetooth device.
7. Press **ENTER**. The **Services** window displays.
8. Pair and activate the desired printer from the list. See *Discovering Bluetooth Device(s) on page 6-31*.
9. Tap **Start > Programs > Windows Explorer**.
10. Open the **Applications** folder.
11. Open the **Samples** folder.
12. Launch **BTVirtualCOM** (Install the Samples from the Desktop if not installed).

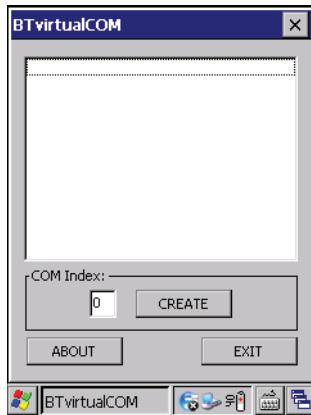

Figure 6-44 *BTVirtualCOM Window*

13. Select the desired printer from the list box.
14. In the **COM Index** text box, enter the COM port value entered in the registry, see step 2b.
15. Tap **Create**.
16. Tap **Start > Programs > Samples > Printing**. (Install the Samples from the Desktop if not installed).
17. Tap **Settings > Printer**.
18. Select the printer from the dialog box and tap **OK**.
19. Tap **File > Print** or **Print without Graphics**.

Headset Services

To connect to a Bluetooth headset:

1. If the wearable computer is not paired with a Bluetooth headset, see *Discovering Bluetooth Device(s) on page 6-31*.
2. Tap **Start > Settings > Control Panel > MotoBTUI**.
3. If Bluetooth is off, select the Bluetooth icon to turn Bluetooth on.
4. Select the **Connections** tab. The wearable terminal lists paired and available Bluetooth devices.
5. Use the navigation key to select the Bluetooth headset.
6. Press **ENTER**. The **Services** window displays.
7. Use the navigation key to select the Bluetooth headset.
8. Press **ENTER**. The wearable computer connects to the Bluetooth headset.

CHAPTER 7 APPLICATION DEVELOPMENT

Introduction

This chapter describes features in Windows CE 7.0 including how to package applications, and procedures for deploying applications onto the wearable terminal.

Software Installation on Development PC

To develop applications to run on the wearable terminal, install the following:

- Microsoft Windows XP (32-bit) or Microsoft Windows Vista (32-bit) or Microsoft Windows 7 (32-bit and 64-bit).
- One of the following device sync components:
 - Microsoft ActiveSync 4.5 or higher for Windows XP
 - Microsoft® Mobile Device Center pre-installed with Windows Vista
 - Microsoft® Windows Mobile Device Center 6.1 or higher for Windows 7.
- Install one or more of the following:
 - Microsoft® Visual Studio 2005 with Service Pack 1
 - Microsoft® Visual Studio 2008 with Service Pack 1
- Enterprise Mobility Developer Kit (EMDK) for C

The EMDK for C is a development tool used to create native C and C++ applications for all Zebra devices. It includes documentation, header files (.H), and library files (.LIB) for native code application development that targets Zebra value-add APIs.
- Platform Software Developer Kit (Platform SDK) for WT41N0

The *Platform SDK for WT41N0* is used in conjunction with the EMDK for C to create Windows CE applications for the wearable terminal. The Platform SDK installs a new Windows CE device type and its associated libraries onto the development PC.

Platform SDK

To download and install the appropriate Platform SDK:

1. Download the appropriate Platform SDK from the Support Central web site, <http://www.zebra.com/support>.
 - a. Select *WT4100*. The *WT4100 Product* page displays.
 - b. On the *WT4100 Product* page, select the appropriate *Platform SDK for WT4100* from the *Software Downloads* section. The *Platform SDK* page displays.
 - c. Save the .exe file to the development computer.
2. Run the file and follow the screen prompts to install.

EMDK for C

To download and install the EMDK for C:

1. Download the appropriate Platform SDK from the Support Central web site, <http://www.zebra.com/support>.
 - a. Select *WT4100*. The *WT4100 Product* page displays.
 - b. On the *WT4100 Product* page, select the appropriate *Enterprise Mobility Developer Kit for C* from the *Software Downloads* section. The *Enterprise Mobility Developer Kit for C* page displays.
 - c. Select the latest version, and save the .exe file to the development computer.
2. Locate the .exe file on the development computer, double-click the executable file and follow the install screen prompts.
3. Once installed, access the components of the EMDK for C from the *Enterprise Mobility Developer Kit for C* program group of the *Windows Start* menu.
4. The sample applications provide examples of how to interface with the Zebra API functions. To build a sample application, open the *Samples* folder from the *Windows Start* menu. Open the folder for the desired sample and then open the project file. The project file has an extension of *vcproj*. Microsoft Visual Studio automatically launches. Select *WinCE* as the Active WCE Configuration. Select *Win32 (WCE ARMV4)* Debug as the active configuration.

Installing Other Development Software

Developing applications for the wearable terminal may require installing other development software, such as application development environments, on the development PC. Follow the installation instructions provided with the software.

Software Updates

Download updates to the EMDK for C from the Support Central web site at: <http://www.zebra.com/support>. Check this site periodically for important updates and new software versions.

Windows CE Flash Storage

In addition to the RAM-based storage standard on the wearable terminal, the wearable terminal is also equipped with a non-volatile Flash-based storage area which can store data (partitions) that can not be corrupted by a cold boot. This Flash area is divided into two categories: Flash File System (FFS) Partitions and Non-FFS Partitions.

FFS Partitions

The wearable terminal includes two FFS partitions. These partitions appear to the wearable terminal as a hard drive that the OS file system can write files to and read files from. Data is retained even if power is removed.

The two FFS partitions appear as two separate folders in the Windows CE file system and are as follows:

- Platform: The Platform FFS partition contains Zebra-supplied programs and Dynamic Link Libraries (DLLs). This FFS is configured to include DLLs that control system operation. Since these drivers are required for basic wearable terminal operation, only experienced users should modify the content of this partition.
- Application: The Application FFS partition is used to store application programs needed to operate the wearable terminal.

Working with FFS Partitions

Because the FFS partitions appear as folders under the Windows CE file system, they can be written to and read like any other folder. For example, an application program can write data to a file located in the Application folder just as it would to the Windows folder. However, the file in the Application folder is in non-volatile storage and is not lost on a cold boot (e.g., when power is removed for a long period of time).

Standard tools such as ActiveSync can be used to copy files to and from the FFS partitions. They appear as the "Application" and "Platform" folders to the ActiveSync explorer. This is useful when installing applications on the wearable terminal. Applications stored in the Application folder are retained even when the wearable terminal is cold booted, just as the Sample Applications program is retained in memory.

There are two device drivers included in the Windows CE image to assist developers in configuring the wearable terminal following a cold boot: RegMerge and CopyFiles.

RegMerge.dll

RegMerge.dll is a built-in driver that allows registry edits to be made to the Windows CE registry. Regmerge.dll runs very early in the boot process and looks for registry files (.reg files) in certain Flash File System folders during a cold boot. It then merges the registry changes into the system registry located in RAM.

Since the registry is re-created on every cold boot from the default ROM image, the RegMerge driver is necessary to make registry modifications persistent over cold boots.

RegMerge is configured to look in the root of two specific folders for .reg files in the following order:

- \Platform
- \Application

Regmerge continues to look for .reg files in these folders until all folders are checked. This allows folders later in the list to override folders earlier in the list. This way, it is possible to override Registry changes made by the Platforms partitions folders. Take care when using Regmerge to make registry changes.



NOTE Regmerge only merges the .reg files on cold boots. The merge process is skipped during a warm boot.

Making modifications to registry values for drivers loaded before RegMerge is not recommended. However, these values may require modification during software development. Since these early loading drivers read these keys before RegMerge gets a chance to change them, the wearable terminal must be cold booted. The warm boot does not re-initialize the registry and the early loading driver reads the new registry values.

Do not use Regmerge to modify built-in driver registry values, or merge the same registry value to two files in the same folder, as the results are undefined.

CopyFiles

Windows CE expects certain files to be in the Windows folder, residing in volatile storage. Windows CE maintains the System Registry in volatile storage. CopyFiles copies files from one folder to another on a cold boot. Files can be copied from a non-volatile partition (Application or Platform) to the Windows or other volatile partition during a cold boot. During a cold boot CopyFiles looks for files with a .CPY extension in the root of the Platform and Application FFS partitions (Platform first and then Application). These files are text files containing the source and destination for the desired files to be copied separated by ">".

Files are copied to the Windows folder from the Flash File System using copy files (*.cpy) in the following order:

```
\Platform
\Application
```

Example:

```
\Application\ScanSamp2.exe>\Windows\ScanSamp2.exe
```

This line directs CopyFiles to copy the ScanSamp2.exe application from the \Application folder to the \Windows folder.

Non-FFS Partitions

Non-FFS partitions include additional software and data pre-loaded on the wearable terminal that can be upgraded. Unlike FFS Partitions, these partitions are not visible when the operating system is running. They also contain system information. Non-FFS partitions include the following:

- Windows CE: The complete Windows CE operating system is stored on Flash devices. If necessary, the entire OS image may be downloaded to the wearable terminal using files provided by Zebra. Any upgrades must be obtained from Zebra. This partition is mandatory for the wearable terminal.
- Splash Screen: a bitmap smaller than 16 Kb (and limited to 16 bits per pixel) is displayed as the wearable terminal cold boots. To download a customized screen to display, see *Creating a Splash Screen on page 7-15*.
- Bootloader: This program interfaces with the host computer and allows downloading via USB cable any or all of the partitions listed above, as well as updated versions of Bootloader. Use caution downloading updated Bootloader versions; incorrect downloading of a Bootloader causes permanent damage to the wearable terminal. Bootloader is mandatory for the wearable terminal.
- Partition Table: Identifies where each partition is loaded in the WT41N0.

Downloading Partitions to the WT41N0

USBDownload is used to specify a hex destination file for each partition and download each file to the WT41N0. This download requires a program loader stored on the wearable terminal. The wearable terminal comes with a program loading utility, Bootloader, stored in the wearable terminal's write-protected flash.

Bootloader

Bootloader allows the user to upgrade the wearable terminal with software updates and/or feature enhancements.

Partition Update vs. File Update

There are two types of updates supported by the wearable terminal: partitions and files. The file system used by the wearable terminal is the same as the file system used on a desktop computer. A file is a unit of data that can be accessed using a file name and a location in the file system. When a file is replaced, only the contents of the previous file are erased. The operating system must be running for a file to be updated, so the Bootloader cannot perform individual file updates as it is a stand-alone program that does not require the operating system to be running.

A typical partition is a group of files, combined into a single “partition” that represents a specific area of storage. Examples of partitions are the flash file systems such as Platform or Application. (Using the desktop computer comparison, these partitions are roughly equivalent to a C: or D: hard disk drive.) In addition to the “hard disk” partitions, some partitions are used for single items such as the operating system, monitor, or splash screen. (Again using a desktop computer comparison, these partitions are roughly the equivalent of the BIOS or special hidden system files.) When a partition is updated, all data that was previously in its storage region is erased - i.e. it is not a merge but rather a replacement operation. Typically, the operating system is not running when partitions are update, so Bootloader can perform partition updates.

All partition images suitable for use by Bootloader are in hex file format for transfer by USBDownloader from the development computer to the wearable terminal.

Upgrade Requirements

Upgrade requirements:

- The hex files to be downloaded (on development computer)
- A connection from the host computer and the wearable terminal
- USBDownloader (on development computer) to download the files.

Once these requirements are satisfied, the wearable terminal can be upgraded by invoking Bootloader and navigating the menus. See *Bootloader on page 7-9* for procedures on downloading a hex file to the wearable terminal.

Deployment

This section provides information about installing software and files on the wearable terminal.

Software deployment can be performed by:

- Copying files from a host computer
- Updating images.

Copying Files from a Host Computer

Copy files to the wearable terminal using ActiveSync or by placing the wearable terminal into mass storage mode.

ActiveSync

To copy files from a host computer to the wearable terminal:

1. Ensure that ActiveSync is installed on the host computer and that a partnership was created. For more information see, [Chapter 3, Synchronization](#).

2. Connect the wearable terminal to the host computer using a Single-slot USB cradle or an appropriate cable. See [Chapter 2, Accessories](#) for connection information.
3. On the host computer, select **Start > Programs > ActiveSync**.

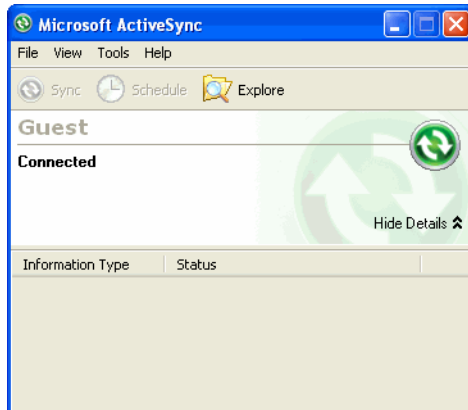

Figure 7-1 ActiveSync Connected Window

4. Select *Explore*.

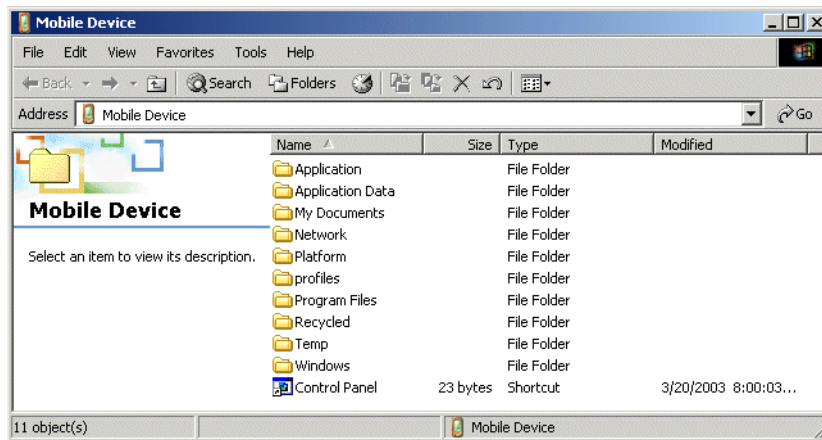

Figure 7-2 ActiveSync Explorer

5. Double-click the folder to expand the folder contents.

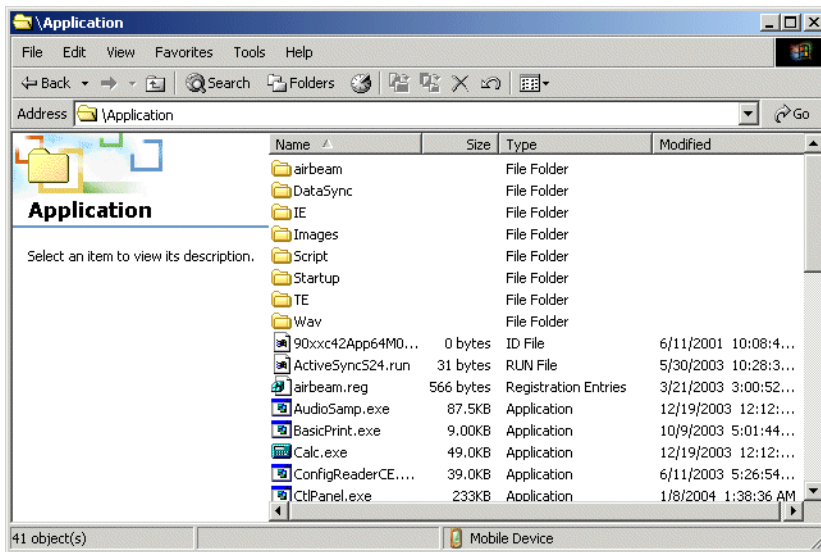

Figure 7-3 Application Folder Contents

- Use Explorer to locate the host computer directory that contains the file to download. Tap that directory in the left pane to display its contents in the right pane.
- Drag the desired file(s) from the host computer to the desired mobile device folder.

Mass Storage

To install an application or copy files to the wearable terminal using a USB connection:

- On the wearable terminal, select **Start > Settings > Control Panel > USBConfig**.

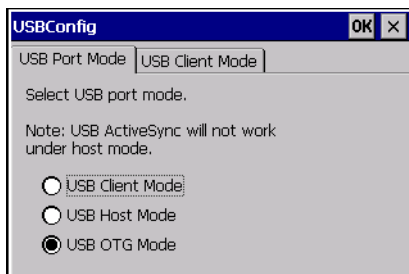

Figure 7-4 USBConfig Window

- On the **USB Port Mode** tab, select **USB Client Mode**.
- On the **USB Client Mode** tab, select **Mass Storage**.
- In the drop-down list, select **Platform** or **Application**.
- Select **OK**.
- Connect the wearable terminal to a host computer using either a Single-slot USB cradle or a USB ActiveSync/Charge cable.
- On the host computer, open **Windows Explorer**. The wearable terminal appears as a hard disk drive in **Windows Explorer**.
- On the host computer, open another **Windows Explorer** window and locate the files to copy to the wearable terminal.

9. Drag the files from the new window to the wearable terminal folder window.
10. When complete, disconnect the wearable terminal from the host computer.

Updating Images

The wearable terminal contains tools that update all operating system components. All updates are distributed as packages and/or hex images. Update packages can contain either partial or complete updates for the operating system. Zebra distributes the update packages on the Support Central Web Site, <http://www.zebra.com/support>.

Update an operating system component using one of the following:

- OS Update
- BootLoader.
- MSP. See *Mobility Services Platform on page 7-15* for information.

OSUpdate Loader

Operating system component can be downloaded to the wearable terminal using the Temp folder.

Using the Temp Folder

To initiate an update using the wearable terminal Temp folder:

1. Go to the Support Central web site, <http://www.zebra.com/support> and download the appropriate update package.
2. Connect the wearable terminal to a host computer using the Single Slot USB Cradle or USB ActiveSync/Charge Cable. See [Chapter 2, Accessories](#).
3. Select **Start > Settings > Control Panel**.
4. Select **System** icon.
5. Select **Memory** tab.

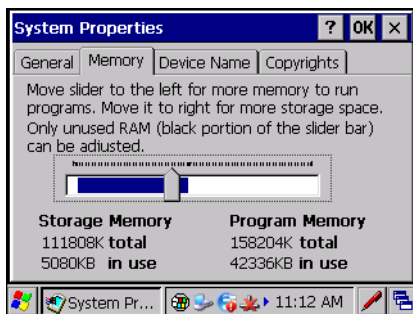

Figure 7-5 *System Properties - Memory Tab*

6. Move the slider to the center position.
7. Select **OK**.
8. Using ActiveSync, copy the update package to the \Temp folder on the wearable terminal.
9. On the wearable terminal, use **Windows Explorer** and navigate to the \Temp folder.
10. Open the **OSUpdate** folder.

11. Select the file: 4100c70Aen_TEMP.Ink.
12. When the Update Loader application finds the appropriate file, it loads the package onto the wearable terminal. A progress bar displays until the update completes.
13. When complete, the wearable terminal re-boots.

Bootloader

Use Bootloader to download hex files to the wearable terminal from a host computer via USB.

WT41N0

Use Bootloader to download customized flash file system partitions to the WT41N0 and load hex files to the flash memory of the WT41N0.

To load the hex files on to the WT41N0 using USB:

1. Download the **USBDownload** application from the Support Central web site. Follow the installation instructions with the application.
2. Connect the WT41N0 to a host computer using the Single-slot USB Cradle or USB ActiveSync/Charge Cable.
3. On the host computer, launch the USBDownload application.

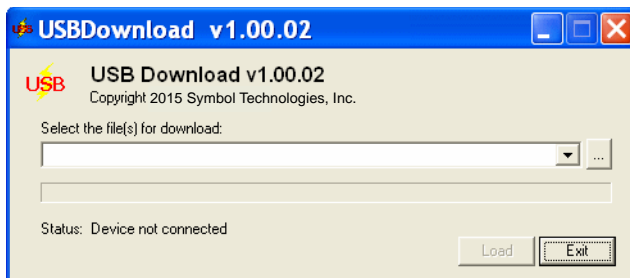

Figure 7-6 USB Download Window

4. Simultaneously press the **Power** button and the **1** and **9** keys.
5. Immediately, as soon as the device starts to boot, press and hold the **P2** key. The Bootloader screen appears.

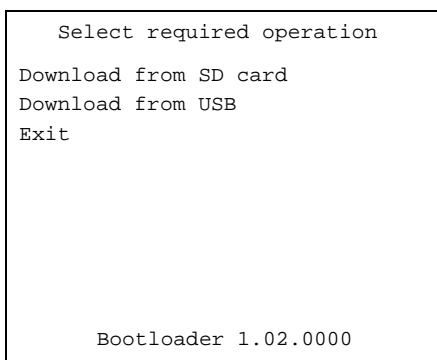

Figure 7-7 Bootloader Menu



CAUTION To ensure a successful download, do not remove power from the WT41N0 while in Bootloader.

1. Use the up and down scroll buttons to select **Download from USB**, then press **ENTER**.
2. The Bootloader displays the following:

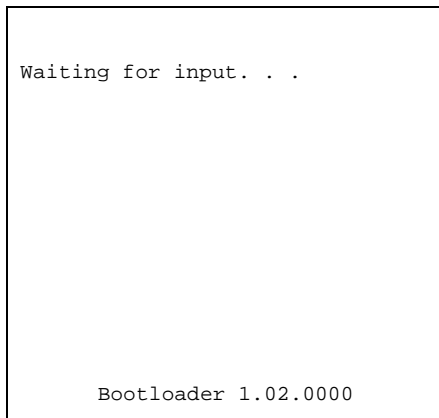

Figure 7-8 *Waiting for Input*

1. On the host computer, locate the hex files to download.



NOTE One hex file or multiple hex files can be selected. To select multiple files, press the Ctrl key while selecting files.

If selecting multiple files to download, USBDownload reads the header of the file and identifies the file type. If the Partition table file is among the files selected, then USBDownload downloads that file first. Similarly, USBDownload downloads the CPLD file last.

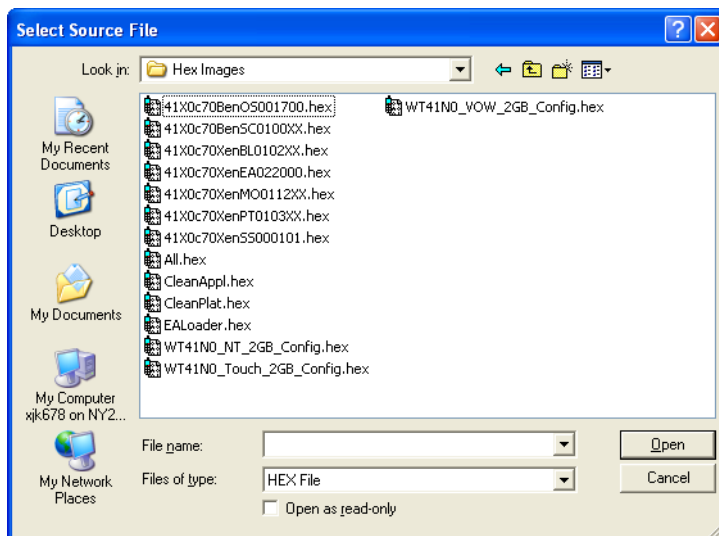

Figure 7-9 *Select Source File Window*

2. Select the hex files and the click **Open**.

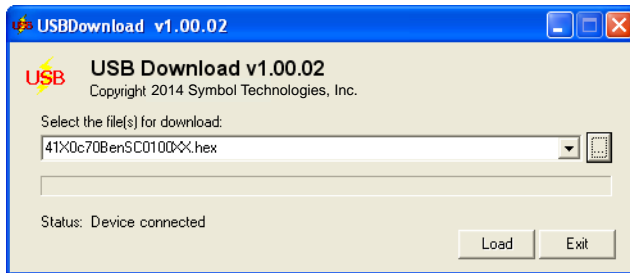

Figure 7-10 *Select Hex File(s)*

3. Click the **LOAD** button. The hex file(s) is downloaded to the device.

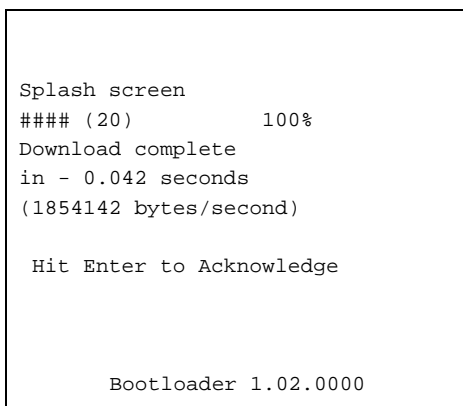

Figure 7-11 *Download Complete Screen*

4. On completion, press **ENTER** to return to the Bootloader main screen to select the next file to download.
5. To exit Bootloader, select **Exit** from the Bootloader main screen and press **ENTER**.

Voice Only WT41N0

Use Bootloader to download customized flash file system partitions to the Voice Only WT41N0 and load hex files to the flash memory of the WT41N0.

To load the hex files on to the Voice Only WT41N0 using USB:

1. Download the **USBDownload** application from the Support Central web site. Follow the installation instructions with the application.
2. Connect the Voice Only WT41N0 to a host computer using the Single-slot USB Cradle or USB ActiveSync/Charge Cable.
3. On the host computer, launch the USBDownload application.

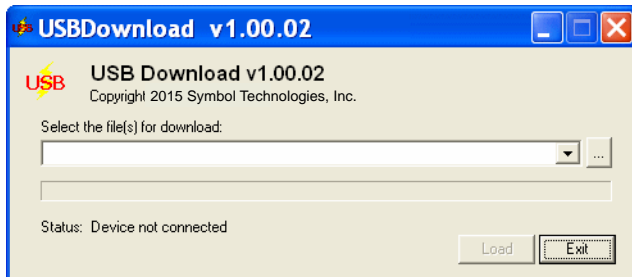

Figure 7-12 USB Download Window

4. Simultaneously press the **Power** button and the **P1** and **P2** keys.
5. Immediately, press and hold the **P2** key. The three LEDs on the front of the Voice Only WT41N0 light indicating that it is in Download mode.



CAUTION To ensure a successful download, do not remove power from the Voice Only WT41N0 while in Bootloader.

6. On the host computer, locate the hex files to download.



NOTE One hex file or multiple hex files can be selected. To select multiple files, press the Ctrl key while selecting files.

If selecting multiple files to download, USBDownload reads the header of the file and identifies the file type. If the Partition table file is among the files selected, then USBDownload downloads that file first. Similarly, USBDownload downloads the CPLD file last.

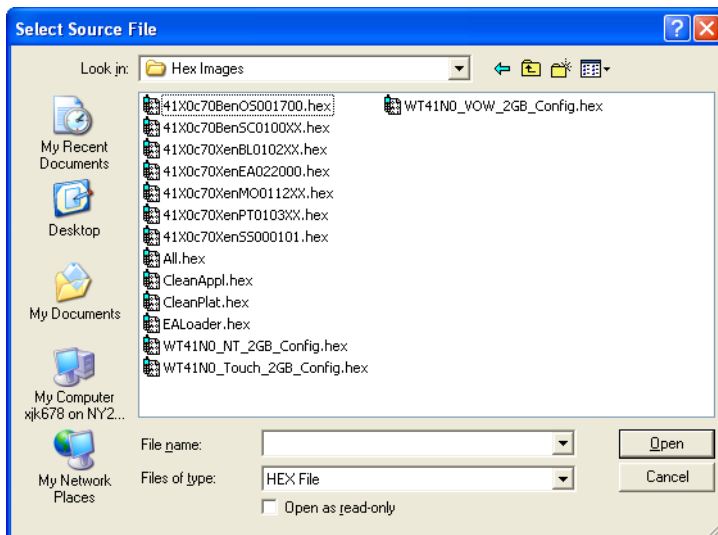

Figure 7-13 Select Source File Window

7. Select the hex files and the click **Open**.

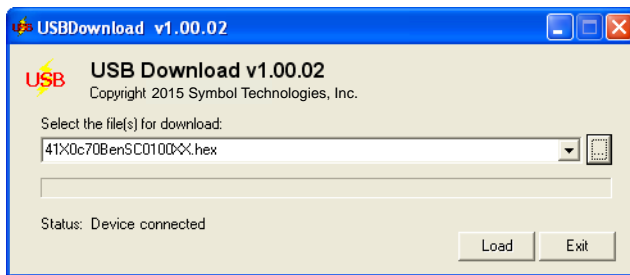

Figure 7-14 Select Hex File(s)

8. Click the **LOAD** button. The hex file(s) is downloaded to the device. The LEDs light from left to right indicating the progress of the file transfer. The Left LED lights at 33%, The left and center LEDs light at 66% and all three LEDs light at 100%.

✓ **NOTE** If an invalid image is selected, the LEDs blink three times.

9. After all the files have been loaded onto the Voice Only WT41N0, simultaneously press the Power button, **P1** and **P2** keys to re-boot the device.

Bootloader Error Detection

While receiving data, Bootloader performs many checks on the data to ensure that the data is received correctly. If an error is detected, Bootloader immediately aborts the download, and reports the error on an error screen.

This error message screen displays until a key is pressed. Once the screen is acknowledged, Bootloader returns to the main menu to wait for a new selection.

To find the probable cause of the error, use the error number and/or the error text displayed on the screen to look up the error in [Table 7-1](#).

Table 7-1 Bootloader Errors

Error Text	Error Number	Probable Cause
Unknown error	-1	A general error occurred. Retry the download. If the failure persists, it is most likely due to a hardware failure; the wearable terminal requires servicing.
Cancelled by user	-2	The user cancelled the download.
Can't open the source	-7	An error occurred opening the source device (either USB or SDMMC). Check source device connectivity and retry.
Can't open the destination	-8	An error occurred opening the destination device (either NAND, RAM, Power Micro, or CPLD). Retry the download. If the failure persists, it is most likely due to a hardware failure; the wearable terminal requires servicing.
Can't read from the source device	-9	The source device (either USB or SDMMC) could not be read from. Check source device connectivity and retry.

Table 7-1 *Bootloader Errors (Continued)*

Error Text	Error Number	Probable Cause
Can't write to the destination device	-10	The destination device (either NAND, RAM, Power Micro, IST, Keyboard Controller or CPLD) could not be written to. Retry the download. If the failure persists, it is most likely due to a hardware failure; the wearable terminal requires servicing.
Transmission checksum error	-11	An error occurred during transmission from the source device (either USB or SDMMC) and the checksum check failed. Check source device connectivity and retry.
Readback checksum error	-12	A checksum, generated from reading back data that was written to the destination device, was incorrect. An error during transmission or a write error to the destination device could cause this.
There is no more heap space available	-14	There is no more heap space available for the download procedure. Restart Bootloader and retry the download. If the failure persists, contact service with details of what is being downloaded.
Invalid data in verify file	-19	The file contains invalid data. Check that the file is suitable for downloading on this terminal.
Insufficient memory for buffering data	-20	There is no more heap space available for the download procedure. Restart Bootloader and retry the download. If the failure persists, contact service with details of what is being downloaded.
Insufficient data available to complete record	-21	A HEX file download was attempted but the HEX file is invalid. Ensure the file is in proper HEX file format.
Invalid HEX file	-23	A HEX file download was attempted but the HEX file is invalid. Ensure the file is in proper HEX file format.
Unrecognized or unsupported HEX record	-24	The HEX file being downloaded contains an invalid or unrecognized HEX record. Ensure the file is in proper HEX file format.
Invalid data in HEX file	-25	The HEX file being downloaded contains invalid data. Ensure the file is in proper HEX file format with valid HEX data.
Exceeded max size	-26	The download file is too large to fit into the space allocated for it. Either make the file smaller or increase the space allocated for it by altering the partition table.
Partition is not valid on this device	-27	The downloaded file specifies a partition entry that does not exist on the device. Only download files that are valid for this device, or change the partition table so that the new file is valid on the device.
Wrong destination code	-28	A specific partition was chosen from the <i>Bootloader</i> main menu but the file selected for download was for another partition. Ensure that the partition selected from the <i>Bootloader</i> main menu matches the file selected for download.
Non-contiguous record found	-30	A HEX file download was attempted but the HEX file is invalid. Ensure the file is in proper HEX file format.

Table 7-1 *Bootloader Errors (Continued)*

Error Text	Error Number	Probable Cause
Timed Out - No data	-31	Bootloader was waiting for data from the source device but timed out before receiving any. Check the source device connectivity and retry.
Invalid file format	-33	The file format is invalid. Only HEX files are supported by Bootloader.
Partition Table not Valid	-34	The size of flash memory is different than that described in the partition table. Retry the download with the correct partition table file.
Invalid data in file	-35	The .bin or .sig file being downloaded contains invalid data. Ensure the file is in proper file format.
File cannot be loaded to this unit	-38	The file contains valid data that indicates it cannot be loaded onto the device.
File validation failed	-40	The file has either been signed incorrectly, or contains data that indicates that it cannot be loaded onto the terminal.

Mobility Services Platform

The MSP Client Software is a set of software components that come pre-installed on the wearable terminal. The MSP Client software consists of the following components:

The RD Client provides support for MSP Staging functionality, provides support for the MSP Legacy Staging process, and provides support for backward-compatible legacy MSP 2.x Legacy Staging functionality.

The MSP Agent provides MSP Provisioning functionality and Control functionality when used with MSP 3.2 Control Edition.

Refer to the *Mobility Services Platform 3.2 User's Guide*, p/n 72E-100158-06, for instructions for using the Rapid Deployment and MSP Agent clients.

Creating a Splash Screen

A custom splash screen can be created and loaded onto the wearable terminal. To create a custom splash screen:

1. Create a .bmp file using a graphic program with the following specifications:
 - Size: 320 (W) x 216 (H).
 - Colors: 256.
2. Modify the bitmap file and save.

To load the splash screen:

1. Convert the bmp file into a hex file using the OSUpdate Package Builder that is part of MSP.
2. Copy the hex file to the wearable terminal using BootLoader. See *Bootloader* on page 7-9.

CHAPTER 8 SPECIAL CONSIDERATIONS

Introduction

This chapter provides special considerations when developing applications for the WT41N0.

Touch Panel User Interface Considerations

When developing applications for a touch panel interface, touch panel activation only by the ball of the finger means there are limitations to what the user interface of an application can expect of a worker

- User interface elements such as buttons, that require activation by a bare finger tip on the touch screen should not be smaller than 10 mm x 10 mm (as opposed to 5 mm x 5 mm if a stylus were an option).
- Do not put user interface elements close to the edge of the display. They're hard to activate and they might not be fully covered by the protective overlay. Keep the touch points at least 2 mm in from the edge.

Tips for Improving Battery Life

To improve the life of the battery:

- Set the display backlight to turn off quickly and reduce the display brightness.
- Set the keypad backlight to turn off quickly.
- Set the wearable computer to suspend when not in use and maximum CPU performance.
- Set the WLAN radio to save maximum power.

After making these settings, they can be saved in Registry files to make them cold-boot persistent.

Display Backlight

- ✓ **NOTE** Changing the Backlight setting on the Voice Only WT41N0 will change the brightness of the Application Controlled LED. Refer to the EMDK Help file WT41N0-VOW Programming page for more information.

To change the display backlight settings in order to conserve battery power:

1. Select **Start > Settings > Control Panel**.
2. Select **Backlight** icon.
3. Select **Battery Power** tab.
4. Ensure that the **Disable backlight if not used for** checkbox is checked.
5. In the drop-down list, select the amount of time after which the display will turn off. Set to **1 minute** or a lower value that the user is comfortable with.

To set the brightness level of the display:

1. Select **Brightness** tab.
2. Move the slider to **2** to conserve power.
3. Select **OK**.

Keypad Light

✓ **NOTE** Changing the Keypad Backlight setting on the Voice Only WT41N0 will change the brightness of the WLAN Status LED. Refer to the EMDK Help file WT41N0-VOW Programming page for more information.

To set the amount of time that the keypad light stays on:

1. Select **Start > Settings > Control Panel**.
2. Select **Keylight** icon.
3. Select **Battery Power** tab.
4. Ensure that the **Disable keylight if not used for** checkbox is checked.
5. In the drop-down list, select the amount of time after which the keypad light will turn off. Set to **1 minute** or a lower value that the user is comfortable with.

To disable the key light from coming on:

1. Select the **Advanced** tab.
2. Ensure that the **Disable keylight** checkbox is checked.

Tap **OK**.

Power

To set the wearable computer to turn off after a short period of non-use:

1. Select **Start > Settings > Control Panel**.
2. Select **Power** icon.
3. Select **Advanced** tab.
4. Ensure that the **Turn off device if not used for** checkbox is checked
5. In the drop-down list, select the amount of time after which the device will turn off. The default setting is 3. If desired, lower this value to 1 to conserve power.

To set the CPU to maximum performance:

1. Select **CPU Power** tab.
2. Ensure that the **Max Power Save** radio button is selected. This selection maximizes battery life.
3. Select **Apply**.
4. Select **OK**.

Wireless LAN

To set the WLAN radio to maximum performance:

1. Select the wireless icon in the bottom lower right corner.
2. Select **Manage Profiles**.
3. Select the wireless profile.
4. Press ENTER.
5. Select **Edit**.
6. Continuously select **Next** until the **Battery Usage Mode** window appears.
7. Ensure the **MAX Power Save** radio button is selected.

Voice Only WT41N0 LED Considerations

- Application developers for the Voice Only WT41N0 should not program all LEDs to be turned on at the same time, as this sequence is reserved for IPL mode.
- Consider device battery life when programming LED blinking. Refer to the EMDK Help file WT41N0-VOW Programming page for more information.

RS5000 Low Charge Considerations

The first scanner detection attempt may fail if the scanner has a very low charge because the built-in power buffer must charge before the imager can turn on. Ensure the application retries scanner detection to allow more time for the scanner to charge the power buffer.

The RS5000 Bluetooth scanner is enabled by default. To disable the Bluetooth scanner to speed the RS5000 start up time, refer to the *WT41N0 User Guide* Datawedge chapter.

CHAPTER 9 MAINTENANCE & TROUBLESHOOTING

Introduction

This chapter includes instructions on cleaning and storing the wearable terminal, and provides troubleshooting solutions for potential problems during wearable terminal operating.

Maintaining the Wearable Terminal

For trouble-free service, observe the following tips when using the wearable computer:

- Do not scratch the touch screen of the wearable computer. When activating with the wearable computer touch screen, use finger tips. Never use a pen or pencil or other sharp object on the surface of the screen.

Zebra requires using a screen protector on the touch screen versions, p/n KT-114032-01R or KT-114032-02R.

- A screen protector is applied to the wearable computer touch screen. Zebra requires using this to minimize wear and tear. Screen protectors enhance the usability and durability of touch screen displays. Benefits include:
 - Protection from scratches and gouges
 - Durable touch surface with tactile feel
 - Abrasion and chemical resistance
 - Keeping the device's screen looking new
 - Quick and easy installation.
- Protect the wearable computer with a touch screen from temperature extremes.
- Do not store or use the wearable computer with a touch screen in any location that is extremely dusty, damp, or wet.
- Use a soft lens cloth to clean the wearable computer display/touch screen.
- Periodically replace the rechargeable Li-ion battery to ensure maximum battery life and product performance. Battery life depends on individual usage patterns.
- The screen of the wearable computer contains glass. Take care not to drop the wearable computer or subject it to strong impact.

- Regularly replace all Velcro® straps on the wrist mount and wearable scanners, to ensure adequate adhesion of the Velcro.
- On touch screen versions, periodically replace the screen protector, especially if it is scratched.

Wrist Mount Cleaning Instructions

It may be necessary to wash the wrist mount straps and replaceable pad when they become soiled.

Remove the straps and pad from the wrist mount. Hand wash in cold water with a mild detergent (such as Woolite®). Do not use bleach. Air dry. Do not use a dryer.

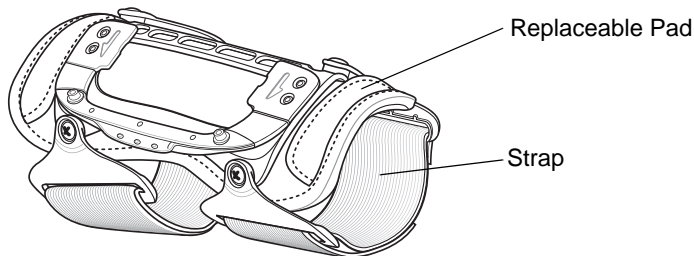

Figure 9-1 Wrist Mount Soft Goods

Arm Sleeve Cleaning Instructions

It may be necessary to wash the arm sleeve when it become soiled.

Hand wash in cold water with a mild detergent (such as Woolite®). Do not use bleach. Air dry. Do not use a dryer.

Removing the Screen Protector

- ✓ **NOTE** Not using a screen protector on a touch panel device can affect warranty coverage. To purchase replacement protectors, contact your local account manager or Zebra Technologies Corporation. These include screen protector installation instructions. Part number: KT-67525-01R or KT-67525-02R Screen Protector 3/pk.

A screen protector is applied to the wearable terminal with touch screen. Zebra mandates using this to minimize wear and tear. Screen protectors enhance the usability and durability of touch screen displays.

To remove the screen protector, lift the corner using a thin plastic card, such as a credit card, then carefully lift it off the display.

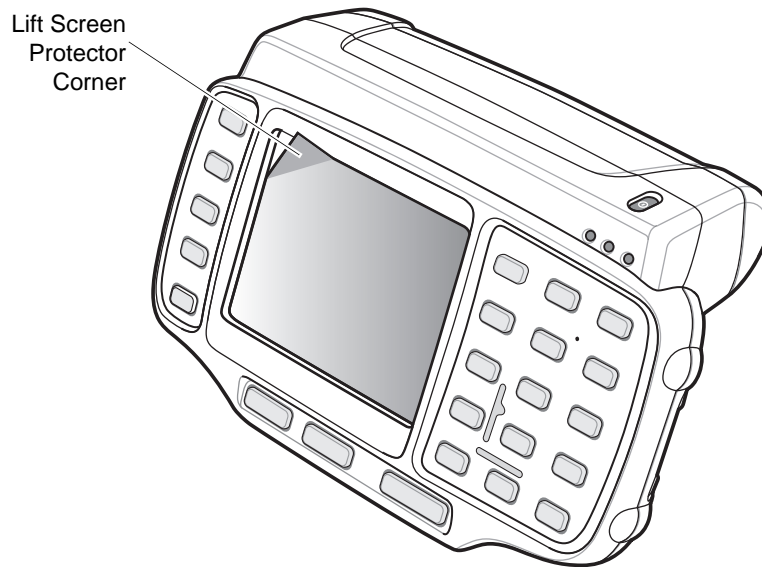

Figure 9-2 *Removing the Screen Protector*



CAUTION Do not use a sharp object to remove the protector. Doing so can damage the touch screen.

Battery Safety Guidelines

- The area in which the units are charged should be clear of debris and combustible materials or chemicals. Particular care should be taken where the device is charged in a non commercial environment.
- Improper battery use may result in a fire, explosion, or other hazard.
- To charge the mobile device battery, the battery and charger temperatures must be between 0 °C and +40 °C (+32 °F and +104 °F).
- Do not use incompatible batteries and chargers. Use of an incompatible battery or charger may present a risk of fire, explosion, leakage, or other hazard. If you have any questions about the compatibility of a battery or a charger, contact Zebra support.
- Do not disassemble or open, crush, bend or deform, puncture, or shred.
- Severe impact from dropping any battery-operated device on a hard surface could cause the battery to overheat.
- Do not short circuit a battery or allow metallic or conductive objects to contact the battery terminals.
- Do not modify or remanufacture, attempt to insert foreign objects into the battery, immerse or expose to water or other liquids, or expose to fire, explosion, or other hazard.
- Do not leave or store the equipment in or near areas that might get very hot, such as in a parked vehicle or near a radiator or other heat source. Do not place battery into a microwave oven or dryer.
- Battery usage by children should be supervised.
- Please follow local regulations to promptly dispose of used re-chargeable batteries.
- Do not dispose of batteries in fire.

- Seek medical advice immediately if a battery has been swallowed.
- In the event of a battery leak, do not allow the liquid to come in contact with the skin or eyes. If contact has been made, wash the affected area with large amounts of water and seek medical advice.
- If you suspect damage to your equipment or battery, contact Zebra support to arrange for inspection.

Cleaning



WARNING! Avoid exposing this product to contact with hot oil or other flammable liquids. If such exposure occurs, unplug the device and clean the product immediately in accordance with these guidelines.



CAUTION Always wear eye protection.

Read warning label on compressed air and alcohol product before using.

If you have to use any other solution for medical reasons please contact Zebra for more information.

Materials Required

- Alcohol wipes
- Soft lens cloth
- Cotton tipped applicators
- Isopropyl alcohol
- Can of compressed air with a tube.

Cleaning the Wearable Terminal

Housing

Using the alcohol wipes, wipe the housing including keys and in-between keys.

Display

The display can be wiped down with the alcohol wipes, but care should be taken not to allow any pooling of liquid around the edges of the display. Immediately dry the display with a soft, non-abrasive cloth to prevent streaking. For WT41N0 with touch panel, only use a soft lens cloth to clean the touch panel overlay surface.

Connectors

Clean all three connectors, two interface connectors on the sides of the wearable terminal and the cradle connector on the back.

1. Remove the main battery from mobile computer. See *Installing the Main Battery on page 1-3*.
2. Remove connector rubber plugs, if required.
3. Dip the cotton portion of the cotton tipped applicator in isopropyl alcohol.

4. Rub the cotton portion of the cotton tipped applicator back-and-forth across each connector. Do not leave any cotton residue on the connector.
5. Repeat at least three times.
6. Use the cotton tipped applicator dipped in alcohol to remove any grease and dirt near the connector area.
7. Use a dry cotton tipped applicator and repeat steps 4 through 7.



CAUTION Do not point nozzle at yourself and others, ensure the nozzle or tube is away from your face.

8. Spray compressed air on the connector areas by pointing the tube/nozzle about ½ inch away from the surface.
9. Inspect the area for any grease or dirt, repeat if required.
10. Replace connector rubber plugs, if required.

Cleaning the RS309, RS409, RS419, RS507 and RS5000

Housing

Using the alcohol wipes, wipe the housing including keys and in-between keys.

Scanner Exit Window

Wipe the scanner exit window periodically with a lens cloth or other material suitable for cleaning optical material such as eyeglasses.

Connectors

1. Disconnect the scanner from mobile computer.
2. Dip the cotton portion of the cotton tipped applicator in isopropyl alcohol.
3. Rub the cotton portion of the cotton tipped applicator back-and-forth across the connector pins. Do not leave any cotton residue on the connector.
4. Repeat at least three times.
5. Use the cotton tipped applicator dipped in alcohol to remove any grease and dirt near the connector area. Use a dry cotton tipped applicator and repeat steps 3 through 5.



CAUTION Do not point nozzle at yourself and others, ensure the nozzle or tube is away from your face.

6. Spray compressed air on the connector area by pointing the tube/nozzle about ½ inch away from the surface.
7. Inspect the area for any grease or dirt, repeat if required.

Cleaning Cradle Connectors

To clean the connectors on a cradle:

1. Remove the DC power cable from the cradle.

2. Dip the cotton portion of the cotton tipped applicator in isopropyl alcohol.
3. Rub the cotton portion of the cotton tipped applicator along the pins of the connector. Slowly move the applicator back-and-forth from one side of the connector to the other. Do not let any cotton residue on the connector.
4. All sides of the connector should also be rubbed with the cotton tipped applicator.



CAUTION Do not point nozzle at yourself and others, ensure the nozzle or tube is away from your face.

5. Spray compressed air in the connector area by pointing the tube/nozzle about ½ inch away from the surface.
6. Ensure that there is no lint left by the cotton tipped applicator, remove lint if found.
7. If grease and other dirt can be found on other areas of the cradle, use lint free cloth and alcohol to remove.
8. Allow at least 10 to 30 minutes (depending on ambient temperature and humidity) for the alcohol to air dry before applying power to cradle.

If the temperature is low and humidity is high, longer drying time is required. Warm temperature and dry humidity requires less drying time.

Cleaning Frequency

The cleaning frequency is up to the customer's discretion due to the varied environments in which the mobile devices are used. They may be cleaned as frequently as required. However when used in dirty environments it may be advisable to periodically clean the ring scanners' exit windows to ensure optimum scanning performance.

Troubleshooting

Wearable Terminal

Table 9-1 *Troubleshooting the Wearable Terminal*

Problem	Cause	Solution
Wearable terminal does not turn on.	Lithium-ion battery not charged.	Charge or replace the lithium-ion battery in the wearable terminal.
	Lithium-ion battery not installed properly.	Ensure battery is installed properly. See <i>Installing and Removing the Main Battery</i> on page 1-3.
	System crash.	Perform a warm boot. If the wearable terminal still does not turn on, perform a cold boot. See <i>Resetting the Wearable Terminal</i> on page 1-8.

Table 9-1 Troubleshooting the Wearable Terminal (Continued)

Problem	Cause	Solution
Rechargeable lithium-ion battery did not charge.	Battery failed.	Replace battery. If the wearable terminal still does not operate, try a warm boot, then a cold boot. See <i>Resetting the Wearable Terminal</i> on page 1-8.
	Wearable terminal removed from cradle while battery was charging.	Insert wearable terminal in cradle and begin charging.
	Ambient temperature of the cradle is too warm or too cold.	Move the cradle to an area where the ambient temperature is between 0 °C and 40 °C (32 °F and 104 °F).
Cannot see characters on display (not applicable to voice only configuration).	Wearable terminal not powered on.	Press the Power button.
Display on touch panel version is hard to read (not applicable to voice only configuration).	Screen protector may be scratched or worn.	Replace screen protector.
During data communication, no data was transmitted, or transmitted data was incomplete.	Wearable terminal removed from cradle or unplugged from host computer during communication.	Replace the wearable terminal in the cradle, or reattach the Synchronization cable and re-transmit.
	Incorrect cable configuration.	See the System Administrator.
	Communication software was incorrectly installed or configured.	Perform setup. See Chapter 2, Accessories for details. Ensure that Microsoft ActiveSync 4.1 or greater is installed on the host computer.
No sound is audible.	Volume setting is low or turned off.	Adjust volume. Change volume settings by selecting Start > Settings > Control Panel > Volume & Sounds icon > Volume tab. Move the slider to change the volume level or use volume control on voice application.

Table 9-1 *Troubleshooting the Wearable Terminal (Continued)*

Problem	Cause	Solution
Wearable terminal turns itself off.	Wearable terminal is inactive.	The wearable terminal turns off after a period of inactivity. If the wearable terminal is running on battery power, this period can be set to 30 sec., 1, 2, 3, 4, 5 or 6 minutes. If the wearable terminal is running on external power, this period can be set to 1, 2, 3, 5, 10, 15 and 30 minutes. Check the power settings by selecting Start > Settings > Control Panel > Power icon > Advanced tab. Change the setting if a longer delay is required before the automatic shutoff feature activates.
	Voice Only WT41N0 was set to suspend.	Return Voice Only WT41N0 suspend setting to factory default (disabled).
	Battery is depleted.	Replace or recharge the battery.
	Battery is not inserted properly.	Insert the battery properly (see <i>Installing and Removing the Main Battery on page 1-3</i>).
	The wearable computer's battery is low and it powers down to protect memory content.	Replace or recharge the battery.
A message appears stating that the wearable terminal memory is full. (not applicable to voice only configuration).	Too many files stored on the wearable terminal.	Delete unused memos and records. You can save these records on the host computer.
	Too many applications installed on the wearable terminal.	If you have installed additional applications on the wearable terminal, remove them to recover memory. Select Start > Settings > Control Panel > Remove Programs icon. Select the unused program and select Remove .

Table 9-1 Troubleshooting the Wearable Terminal (Continued)

Problem	Cause	Solution
The wearable terminal does not accept scan input.	Scanning application is not loaded.	Verify that the unit is loaded with a scanning application. See the System Administrator.
	Unreadable bar code.	Ensure the symbol is not defaced.
	Distance between exit window and bar code is incorrect.	Ensure wearable terminal is within proper scanning range.
	Wearable terminal is not programmed for the bar code.	Ensure the wearable terminal is programmed to accept the type of bar code being scanned.
	Wearable terminal is not programmed to generate a beep.	If a beep on a good decode is expected and a beep is not heard, check that the application is set to generate a beep on good decode.
	Battery is low.	If the scanner stops emitting a laser beam when the trigger is pressed, check the battery level. When the battery is low, the scanner shuts off before the wearable terminal low battery condition notification. Note: If the scanner is still not reading symbols, contact the distributor or Zebra.
Wearable terminal goes into IPL mode after cold boot.	Headset adapter without a headset is connected to the wearable terminal during a cold boot.	Disconnect the headset adapter prior to performing a cold boot.
	Scanner trigger is held down during a cold boot.	Do not press trigger during a cold boot.
	P1 or P2 key is held down during a cold boot.	Do not press the P1 or P2 key during a cold boot.
If all three LEDs are lit solid.	Voice Only WT41N0 is in IPL mode.	Perform cold boot. See <i>Resetting the Wearable Terminal on page 1-8</i> .
WLAN connection is lost when the wearable terminal is connected to a host computer using ActiveSync.	Microsoft security feature prevents connection to two separate networks.	Disconnect from the WLAN network prior to connecting to a host computer using ActiveSync.

Four Slot Spare Battery Charger

Table 9-2 *Troubleshooting The Four Slot Spare Battery Charger*

Symptom	Possible Cause	Solution
Batteries not charging.	Battery was removed from the charger or charger was unplugged from AC power too soon.	Re-insert the battery in the charger or re-connect the charger's power supply.
	Battery is faulty.	Verify that other batteries charge properly. If so, replace the faulty battery.
	Battery contacts not connected to charger.	Verify that the battery is seated in the battery well correctly with the contacts facing down.
	Ambient temperature of the charger is too warm or too cold.	Move the charger to an area where the ambient temperature is between 0 °C and 40 °C.

Four Slot Ethernet Cradle

Table 9-3 *Troubleshooting the Four Slot Ethernet Cradle*

Problem	Cause	Solution
Wearable terminal amber Charge Status LED does not light when wearable terminal inserted.	Cradle is not receiving power.	Ensure the power cable is connected securely to both the cradle and to AC power.
	Wearable terminal is not correctly seated.	Remove and re-insert the wearable terminal into the cradle, ensuring it is correctly seated.
Wearable terminal battery is not charging.	Wearable terminal was removed from cradle or cradle was unplugged from AC power too soon.	Ensure cradle is receiving power. Ensure the wearable terminal is seated correctly.
	Battery is faulty.	Verify that other batteries charge properly. If so, replace the faulty battery.
	The wearable terminal is not fully seated in the cradle.	Remove and re-insert the wearable terminal into the cradle, ensuring it is correctly seated.
	Ambient temperature of the cradle is too warm or too cold.	Move the cradle to an area where the ambient temperature is between 0 °C and 40 °C (32 °F and 104 °F).

Table 9-3 Troubleshooting the Four Slot Ethernet Cradle (Continued)

Problem	Cause	Solution
During data communication, no data was transmitted, or transmitted data was incomplete.	Wearable terminal removed from cradle during communication.	Replace wearable terminal in cradle and retransmit.
	Incorrect cable configuration.	See the system administrator.
	Ethernet connection error. Link LED is not lit (see <i>Four Slot Ethernet Cradle</i> on page 2-6).	See the system administrator. Probable Ethernet connection error.

Single Slot USB Cradle

Table 9-4 Troubleshooting the Single Slot USB Cradle

Symptom	Possible Cause	Action
LEDs do not light when wearable terminal or spare battery is inserted.	Cradle is not receiving power.	Ensure the power cable is connected securely to both the cradle and to AC power.
	Wearable terminal is not seated firmly in the cradle.	Remove and re-insert the wearable terminal into the cradle, ensuring it is firmly seated.
	Spare battery is not seated firmly in the cradle.	Remove and re-insert the spare battery into the charging slot, ensuring it is firmly seated.
Wearable terminal battery is not charging.	Wearable terminal was removed from cradle or cradle was unplugged from AC power too soon.	Ensure cradle is receiving power. Ensure wearable terminal is seated correctly. Confirm main battery is charging. View battery status by selecting Start > Settings > Control Panel > Power icon.
	Battery is faulty.	Verify that other batteries charge properly. If so, replace the faulty battery.
	The wearable terminal is not fully seated in the cradle.	Remove and re-insert the wearable terminal into the cradle, ensuring it is firmly seated.
	Ambient temperature of the cradle is too warm or too cold.	Move the cradle to an area where the ambient temperature is between 0 °C and 40 °C (32 °F and 104 °F).
Spare battery is not charging.	Battery not fully seated in charging slot.	Remove and re-insert the spare battery into the cradle, ensuring it is firmly seated.
	Battery inserted incorrectly.	Ensure the contacts are facing down and toward the back of the cradle.
	Battery is faulty.	Verify that other batteries charge properly. If so, replace the faulty battery.

Table 9-4 Troubleshooting the Single Slot USB Cradle (Continued)

Symptom	Possible Cause	Action
During data communications , no data was transmitted, or transmitted data was incomplete.	Wearable terminal removed from cradle during communications.	Replace wearable terminal in cradle and retransmit.
	Incorrect cable configuration.	See the System Administrator.
	Communications software is not installed or configured properly.	Perform setup as described in Chapter 2, Accessories . Ensure that Microsoft ActiveSync 4.1 or greater is installed on the host computer.
Cannot ActiveSync with Host Computer	Wrong USB cable used.	Ensure that the cable has a USB A connector on one end and a USB mini B connector on the other end.
	Host computer not configured properly.	Ensure that ActiveSync on the host computer is set to allow USB connections.
	The wearable computer is not fully seated in the cradle.	Remove and re-insert the wearable computer into the cradle, ensuring it is firmly seated.

Appendix A Technical Specifications

Technical Specifications

The following tables summarize the wearable terminal's intended operating environment and general technical hardware specifications.

Wearable Terminal

The following table summarizes the wearable terminal's intended operating environment.

Table A-1 *Technical Specifications*

Item	Description
Physical and Environmental Characteristics	
Dimensions	With Standard Battery: 14.2 cm L x 9.3 cm H x 2.6 cm H (5.7 inches L x 3.7 inches W x 1.0 inch H) With Extended Battery: 14.2 cm L x 10.7 cm H x 2.6 cm H (5.7 inches L x 4.2 inches W x 1.0 inch H)
Weight (including battery)	With Standard Battery: 320 g (11.3 oz.) With Extended Battery: 369 g (13.0 oz.)
Keyboard	WT41N0: Alphanumeric Keypad Voice Only WT41N0: Three programmable function keys.
Display	WT41N0: Color 2.8 inch QVGA non-touch or touch screens Voice Only WT41N0: None
Main Battery	Removable, rechargeable 3.7 VDC Lithium Ion battery. Standard capacity: 2330 mAh (minimum) Extended capacity: 4600 mAh (minimum)
Backup Battery	NiMH battery (rechargeable) 15 mAh 2.4 VDC (not user accessible)
Performance Characteristics	

Table A-1 *Technical Specifications (Continued)*

Item	Description
CPU	OMAP4 processor at 1 GHz
Operating System	Microsoft Windows Embedded CE 7.0 Compact
Memory	2 GB Flash/512 MB RAM
Data Capture Options	RS309 scanner RS409 scanner RS419 scanner RS507 Hands-free Imager RS5000 Hands-free Imager
User Environment	
Operating Temperature	-4 °F to 122°F (-20 °C to 50 °C)
Storage Temperature	-40 °F to 158 °F (-40 °C to 70 °C)
Battery Charging Temperature	32 °F to 104 °F (0 °C to +40 °C) ambient temperature range.
Humidity	5% to 95% non condensing
Drop Specification	Multiple 1.2 m (4 ft.) drops to concrete across operating temperature range
Tumble	500 half-meter tumbles at room temperature (1,000 drops)
Environmental Sealing	IP54
ESD	± 15k VDC air discharge ± 8k VDC direct discharge ± 8k VDC indirect discharge
WLAN Wireless Data Communications	
WLAN radio	802.11a/b/g/n
Operating Channels	Channel 8 - 169 (5040 - 5845 MHz) (4920 - 4980 MHz) Japan only Channel 1 - 13 (2412 - 2472 MHz) Channel 14 (2484 MHz) Japan only Actual operating frequencies depend on regulatory rules and certification agency
Security	Security Modes: Legacy, WPA and WPA2 Encryption: WEP (40 or 128 bit), TKIP and AES Authentication: TLS, TTLS (MS-CHAP), TTLS (MS-CHAP v2), TTLS (CHAP), TTLS (MD5), TTLS (PAP), PEAP-TLS, PEAP (MSCHAP v2), PEAP (EAP-GTC), EAP-FAST-TLS, EAP-FAST (MS-CHAP v2), WEAP-FAST (EAP-GTC) and LEAP
Voice Communication	Runs voice recognition engines and text-to-speech engines for voice picking applications
Output Power	100 mW U.S. and International
Data Rate	802.11a: up to 54Mb per second 802.11b: up to 11Mb per second 802.11g: up to 54Mb per second 802.11n: up to 72.2 Mb per second

Table A-1 *Technical Specifications (Continued)*

Item	Description
Frequency Range	802.11a: 5 GHz; country-dependent 802.11b: 2.4 GHz; country-dependent 802.11g: 2.4 GHz; country-dependent 802.11n: 2.4 GHz; country-dependent
Antenna	Internal
WPAN Wireless Data Communications	
Bluetooth	Bluetooth Version 2.1 +EDR

RS309 Scanner

Table A-2 *RS309 Technical Specifications*

Item	Description
Physical and Environmental Characteristics	
Dimensions (standard version without cables attached)	6.8 cm L x 6.1 cm H x 3.8 cm (2.7 inch L x 2.4 inch W x 1.5 inch H)
Weight (standard version without cables attached)	98 g (3.525 oz.)
Current	140 mA typical, 180 mA max
Standby Current	60 μ A max
Voltage	3.1 to 3.6 VDC
Vcc Noise Level	200 mV p-p max.
Performance Characteristics	
Light Source	650 nm LASER, 1.06 mW
Scan Rate	35 (\pm 5) scans/sec (bidirectional)
Yaw	\pm 50 degrees from normal
Roll	\pm 20 degrees from vertical
Pitch	\pm 65 degrees from normal
User Environment	
Operating Temperature	-22 °F to 122 °F (-30 °C to 50 °C)
Storage Temperature	-40 °F to 140 °F (-40 °C to 60 °C)
Humidity	5% to 95% non condensing

Table A-2 RS309 Technical Specifications (Continued)

Item	Description
Drop Specification	4 ft.(1.8m) drop to concrete
Environmental Sealing	IP54 sealing
Ambient Light Immunity	Tolerant to typical artificial indoor and natural outdoor (direct sunlight) lighting conditions. Fluorescent, Incandescent, Mercury Vapor, Sodium Vapor, LED ¹ : 450 foot candles (4,844 lux) Sunlight: 8000 foot candles (86,111 lux) ¹ LED lighting with high AC ripple content can impact scanning performance.

RS409 Scanner

Table A-3 RS409 Technical Specifications

Item	Description
Physical and Environmental Characteristics	
Dimensions	(4.8 cm L x 3.6 cm H x 4.8 cm H) 1.9 in. L x 1.4 in. W x 1.9 in. H
Weight (standard version without cables attached)	56.7 gm (2.0 oz.)
Current	92 mA typical, 121 mA max
Standby Current	12 μ A typical/60 μ A max
Voltage	3.1 to 3.6 VDC
Vcc Noise Level	100 mV p-p max.
Performance Characteristics	
Light Source	650 nm LASER, 1.55 mW
Scan Rate	104 (\pm 12) scans/sec (bidirectional)
Scan Angle	Programmable: 35° and 47°
Yaw	\pm 50 degrees from normal
Roll	\pm 35 degrees from vertical
Pitch	\pm 65 degrees from normal
User Environment	
Operating Temperature	-20 °C to 50 °C (-4 °F to 122 °F)
Storage Temperature	-40 °C to 70 °C (-25 °F to 160 °F)
Humidity	5% to 95% non condensing

Table A-3 RS409 Technical Specifications (Continued)

Item	Description
Drop Specification	1.8m (4 ft.) drop to concrete
Environmental Sealing	IP54 sealing
Ambient Light Immunity	Tolerant to typical artificial indoor and natural outdoor (direct sunlight) lighting conditions. Fluorescent, Incandescent, Mercury Vapor, Sodium Vapor, LED ¹ : 450 foot candles (4,844 lux) Sunlight: 8000 foot candles (86,111 lux) ¹ LED lighting with high AC ripple content can impact scanning performance.

RS419 Scanner

Table A-4 RS419 Technical Specifications

Item	Description
Physical and Environmental Characteristics	
Dimensions	4.8 cm L x 3.6 cm H x 4.8 cm H (1.9 in. L x 1.4 in. W x 1.9 in. H)
Weight (standard version without cables attached)	56.7 gm (2.0 oz.)
Current	92 mA typical, 121 mA max
Standby Current	12µA typical/60 µA max
Voltage	3.1 to 3.6 VDC
Vcc Noise Level	100 mV p-p max.
Performance Characteristics	
Light Source	650 nm LASER, 1.77 mW peak power
Scan Rate	104 (± 12) scans/sec (bidirectional)
Scan Angle	Programmable: 10°, 35° and 47°
Yaw	± 40 degrees from normal
Roll	± 35 degrees from vertical
Pitch	± 65 degrees from normal
User Environment	
Operating Temperature	-20 °C to 60 °C (-4 °F to 140 °F)
Storage Temperature	-40 °C to 70 °C (-25 °F to 160 °F)
Humidity	5% to 95% non condensing

Table A-4 RS419 Technical Specifications (Continued)

Item	Description
Drop Specification	Multiple 1.2 m (4 ft.) drop to concrete from -20 °C to 50 °C (-4 °F to 122 °F). Multiple 0.9 m (3 ft.) drop to concrete at (-30 °C (-22 °F)).
Environmental Sealing	IP54
Ambient Light Immunity	Tolerant to typical artificial indoor and natural outdoor (direct sunlight) lighting conditions. Fluorescent, Incandescent, Mercury Vapor, Sodium Vapor, LED ¹ : 450 foot candles (4,844 lux) Sunlight: 8000 foot candles (86,111 lux) ¹ LED lighting with high AC ripple content can impact scanning performance.

RS507 Scanner

Table A-5 RS507 Technical Specifications

Item	Description																																								
Physical and Environmental Characteristics																																									
Dimensions	Triggerless, standard battery: 2.9 x 5.3 x 7.4 cm (1.16 x 2.1 x 2.92 in.) Triggerless, extended battery: 3.6 x 5.3 x 7.4 cm (1.42 x 2.1 x 2.92 in.) Triggered, standard battery: 2.9 x 5.3 x 7.4 cm (1.16 x 2.1 x 2.92 in.) Triggered, corded (cord length not included): 3.3 x 5.3 x 7.4 cm (1.3 x 2.1 x 2.92 in.)																																								
Weight	Triggerless, standard battery: 121.4 g (4.3 oz.) Triggerless, extended battery: 146.4 g (5.2 oz.) Triggered, standard battery: 134.8 g (4.8 oz.) Triggered, corded: 140.8 g (5.0 oz.)																																								
Performance Characteristics																																									
Optical Resolution	WVGA 752 H x 480 V pixels (gray scale)																																								
Skew	± 60° from normal																																								
Roll	360°																																								
Pitch	± 60° from normal																																								
Aiming Element	655 nm ± 10 nm Visible Laser Diode																																								
Illumination Element	637 nm ± 5 nm Red LEDs																																								
Field of View	Horizontal: 39.6°; Vertical: 25.7°																																								
Nominal Working Distance	<table border="1"> <tbody> <tr> <td>Density</td> <td>5 mil</td> <td>7.5 mil</td> <td>20 mil</td> <td>13 mil</td> </tr> <tr> <td>1D Code Type</td> <td>39</td> <td>39</td> <td>39</td> <td>UPC</td> </tr> <tr> <td>Near</td> <td>2"</td> <td></td> <td></td> <td>1.5"</td> </tr> <tr> <td>Far</td> <td>7.4"</td> <td>10.5"</td> <td>24.6"</td> <td>15.4"</td> </tr> <tr> <td>Density</td> <td>6.67 mil</td> <td>10 mil</td> <td>15 mil</td> <td></td> </tr> <tr> <td>2D Code Type</td> <td>PDF417</td> <td>PDF417</td> <td>PDF417</td> <td></td> </tr> <tr> <td>Near</td> <td>3.3"</td> <td></td> <td></td> <td></td> </tr> <tr> <td>Far</td> <td>7.0"</td> <td>10"</td> <td>14.6"</td> <td></td> </tr> </tbody> </table>	Density	5 mil	7.5 mil	20 mil	13 mil	1D Code Type	39	39	39	UPC	Near	2"			1.5"	Far	7.4"	10.5"	24.6"	15.4"	Density	6.67 mil	10 mil	15 mil		2D Code Type	PDF417	PDF417	PDF417		Near	3.3"				Far	7.0"	10"	14.6"	
Density	5 mil	7.5 mil	20 mil	13 mil																																					
1D Code Type	39	39	39	UPC																																					
Near	2"			1.5"																																					
Far	7.4"	10.5"	24.6"	15.4"																																					
Density	6.67 mil	10 mil	15 mil																																						
2D Code Type	PDF417	PDF417	PDF417																																						
Near	3.3"																																								
Far	7.0"	10"	14.6"																																						

Table A-5 RS507 Technical Specifications (Continued)

Item	Description
Ambient Light Immunity	From total darkness Indoor: 450 ft. candles (4,845 lux). Outdoor: 9,000 ft. candles (96,900 lux).
Motion Tolerance	63.5 cm (25 inches) per second, typical.
Supported Symbologies	Codabar, Code 39, Code 128, EAN-13, EAN-8, Interleaved 2 of 5, UPC-A and UPC-E. Code 11, Code 32 Pharmaceutical (PARAF), Code 93, MSI, Reduced Space Symbology (RSS-14, RSS Limited, RSS Expanded), Straight 2 of 5 IATA (two-bar start/stop), Straight 2 of 5 Industrial (three-bar start/stop), Trioptic, UPC-E1. 4-CB (4-State Customer Bar code), Aztec, MicroPDF417, PDF417, MaxiCode. Australian Post, British Post (4 state code and "infomail"), Data Matrix, Japanese Post, KIX (Netherlands) Post, Planet Code, Postnet, QR Code, EAN/UCC Composite, TCIF Linked Code 39 (TLC39).
Supported Aiming Modes	Class 2 Laser, cross hair with bright center for sunlight visibility; Pick List mode option.
Interface	Cordless: Bluetooth: Class II, v 2.1 with Adaptive Frequency Hopping (AFH). Supported profiles: Serial Port Profile (SPP), Human Interface Device Profile (HID), Service Discovery Application Profile (SDAP). Pairing: by reading terminal BT address as bar code off the display or from a printed label. Corded (to WT41N0): Serial.
User Interface	
LED	Two (parallel), multi color, rear left and rear right.
Beeper	Rear center, up to 80 dBA SPL @ 10 cm.
Restore Key	User accessible for emergency boot up and Bluetooth reconnect (after excessive disconnection period).
Scan Triggering	Manual or automatic using Interactive Sensing Technology (IST).
User Environment	
Operating Temperature	-20 °C to 55 °C (-4 °F to 131 °F)
Storage Temperature	-40° to 70° C (-40° to 158° F) excluding battery -40° to 60° C (-40° to 140° F) including battery
Humidity	5% to 85% non condensing
Drop Specification	1.8 m (6 ft.) multiple drops to concrete across operating temperature range.
Environmental Sealing	IP54
Electrostatic Discharge (ESD)	±15kV air discharge, ±8kV direct discharge.

Table A-5 RS507 Technical Specifications (Continued)

Item	Description
Power	
Cordless	Standard battery: Li-Ion 970 mAh, 3.7 V with up to 35,000 scans (continuous) or up to 10 hours with 900 scans per hour on a single charge using fresh batteries. Extended battery: Li-Ion 1940 mAh, 3.7 V with up to 70,000 scans (continuous) or up to 20 hours with 900 scans per hour on a single charge using fresh batteries.
Corded	Corded adaptor to WT41N0.

RS5000 Scanner

Table A-6 RS5000 Technical Specifications

Item	Description
Physical and Environmental Characteristics	
Dimensions	51.5 mm L x 32 mm W x 27.5 mm D (2.0 in. L x 1.26 in. W x 1.1 in. D)
Weight (standard version without cables attached)	50 g (1.8 oz.)
Current	450 mA typical, 500 mA max
Standby Current	0.60 mA
Voltage	3.1 to 3.6 VDC
Vcc Noise Level	100 mV p-p max.
Performance Characteristics	
Aiming Element	610 nm LED
Illumination	One Hyper Red 660 nm LED
Field of View	Horizontal: 42°, Vertical: 28°
Roll	360 degrees
Pitch	± 60 degrees from normal
Skew	± 60 degrees from normal
User Environment	
Operating Temperature	-30 °C to 50 °C (-22 °F to 122 °F)
Storage Temperature	-40 °C to 60 °C (-25 °F to 140 °F)
Humidity	5% to 95% non condensing

Table A-6 RS5000 Technical Specifications (Continued)

Item	Description
Drop Specification	Multiple 1.2 m (4 ft.) drops to concrete from -30 °C to 50 °C (-22 °F to 122 °F).
Environmental Sealing	IP54
Ambient Light Immunity	Tolerant to typical artificial indoor and natural outdoor (direct sunlight) lighting conditions. Fluorescent, Incandescent, Mercury Vapor, Sodium Vapor, LED ¹ : 450 foot candles (4,844 lux) Sunlight: 9000 foot candles (96,900 lux) ¹ LED lighting with high AC ripple content can impact scanning performance.

Accessories

Table A-7 Single Slot USB Cradle Specification

Feature	Description
Operating Temperature	0 °C to +50 ° (32 °F to 122 °F)
Storage Temperature	-40 °C to 70 °C (-40 °F to 158 °F)
Battery Charging Temperature	0 °C to +40 °C (32 °F to 104 °F) ambient temperature
Humidity	5% to 95% non-condensing
Size (L x W x H)	16.8 cm x 13.0 cm x 9.9 cm (6.6 in. x 5.1 in. x 3.9 in.)
Weight	344 gm (12.1 oz.)
Power Supply	12 VDC, 3.3 A
Drop	76.2 cm (30 inches) to vinyl covered concrete
Electrostatic Discharge (ESD)	±15 kV air discharge, ± 8 kV contact discharge
Typical Power	20 W

Table A-8 Four Slot Ethernet Cradle Specification

Feature	Description
Operating Temperature	0 °C to +50 °C (32 °F to 122 °F)
Storage Temperature	-40 °C to 70 °C (-40 °F to 158 °F)
Battery Charging Temperature	0 °C to +40 °C (32 °F to 104 °F) ambient temperature
Humidity	5% to 95% non-condensing
Size (L x W x H)	17.0 cm x 48.1 cm x 11.4 cm (6.7 in. x 18.9 in. x 4.5 in.)
Weight	1300 gm (45.9 oz.)
Power Supply	12 VDC, 9 A

Table A-8 *Four Slot Ethernet Cradle Specification (Continued)*

Feature	Description
Drop	76.2 cm (30 inches) to vinyl covered concrete
Electrostatic Discharge (ESD)	±15 kV air discharge, ± 8 kV contact discharge
Typical Power	60 W

Table A-9 *Four Slot Spare battery Charger Specification*

Feature	Description
Operating Temperature	0 °C to +40 °C (32 °F to 104 °F)
Storage Temperature	-40 °C to 70 °C (-40 °F to 158 °F)
Battery Charging Temperature	0 °C to +40 °C (32 °F to 104 °F) ambient temperature
Humidity	5% to 95% non-condensing
Size (L x W x H)	21.5 cm x 14.5 cm x 4.9 cm (8.5 in. x 5.7 in. x 1.9 in.)
Weight	435 gm (15.3 oz.)
Power Supply	12 VDC, 3.3 A
Drop	76.2 cm (30 inches) to vinyl covered concrete
Electrostatic Discharge (ESD)	±15 kV air discharge, ± 8 kV contact discharge
Typical Power	25 W

Wearable Terminal Interface Connector Pin-Outs

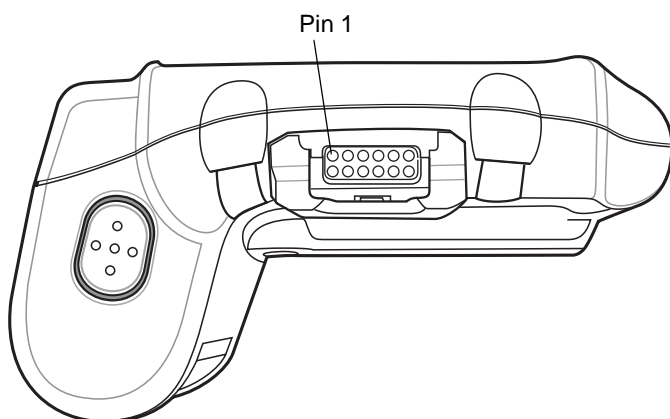

Figure A-1 Pin Locations

Table A-10 Interface Connector Pin-Outs

PIN	Signal Name	Function
1	SCANNER_DETECT_RIGHT	Scanner detect.
2	USBH_N_RIGHT	USB host negative.
3	GND	Digital/system ground.
4	USBH_P_RIGHT	USB host positive.
5	A_GND	Analog ground.
6	HPOUTL_RIGHT_MIC+	Mic+ (default) or headphone out left.
7	U2_RXD	Scanner serial RXD.
8	HPOUTER_RIGHT	Headphone out right.
9	U2_TXD	Scanner serial TXD.
10	SCAN_PWR	Scanner 3.3 VDC power out.
11	U2_CTS	Scanner serial CTS (default if laser scanner plugged in), or Audio Ground sense/MIC- (default if audio connector plugged in).
12	U2_RTS	Scanner serial RTS.

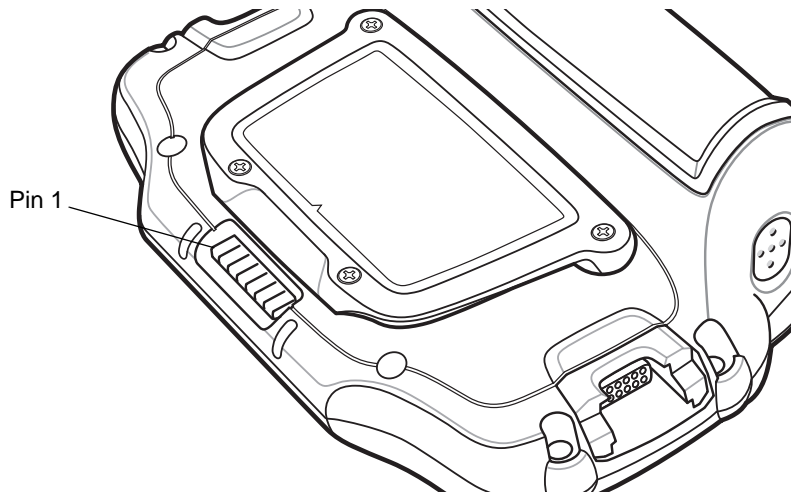

Figure A-2 Cradle Connector Pin Locations

Table A-11 Cradle Connector Pin-Outs

PIN Number	Signal Name	Function
1	Power In	5.4 VDC input power.
2	ACC_OTG_VBUS	5.0 VDC input in client mode, 5.0 VDC output in host mode.
3	ACC_OTG_DP	USB data positive.
4	ACC_OTG_DM	USB data negative.
5	System GND	System ground.
6	ACC_OTG_ID	USB host/client ID pin input. (Low = USB Host, High = USB Client).
7	System Ground	System ground.

Decode Zones

RS309

The RS309 has a selectable scan angle of either 30° or 42°. The 30° scan angle decodes are shown in *Figure A-3* and the 42° scan angle decodes are shown in *Figure A-4*. *Table A-12* lists the typical distances for the 30° and 42° scan angles for selected bar code densities. The minimum element width (or “symbol density”) is the width in mils of the narrowest element (bar or space) in the symbol.

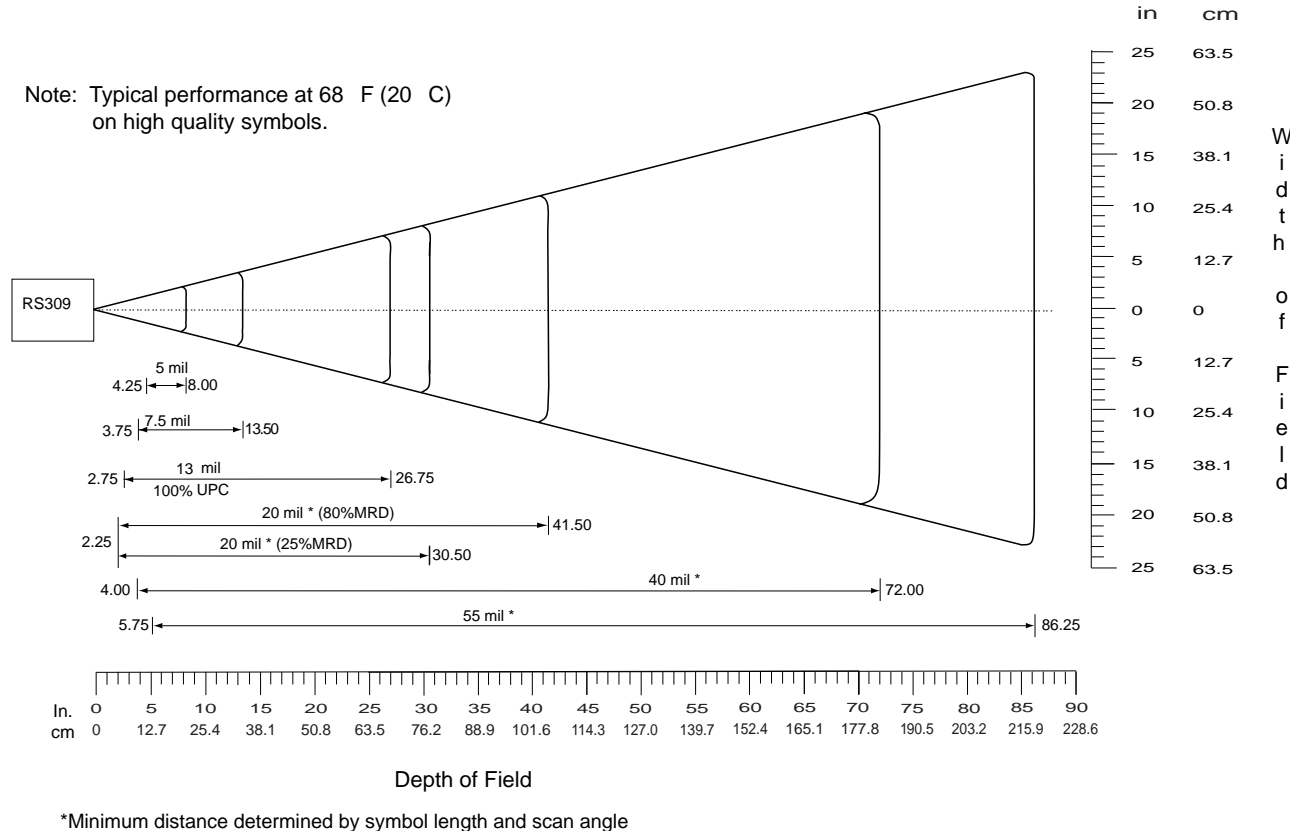
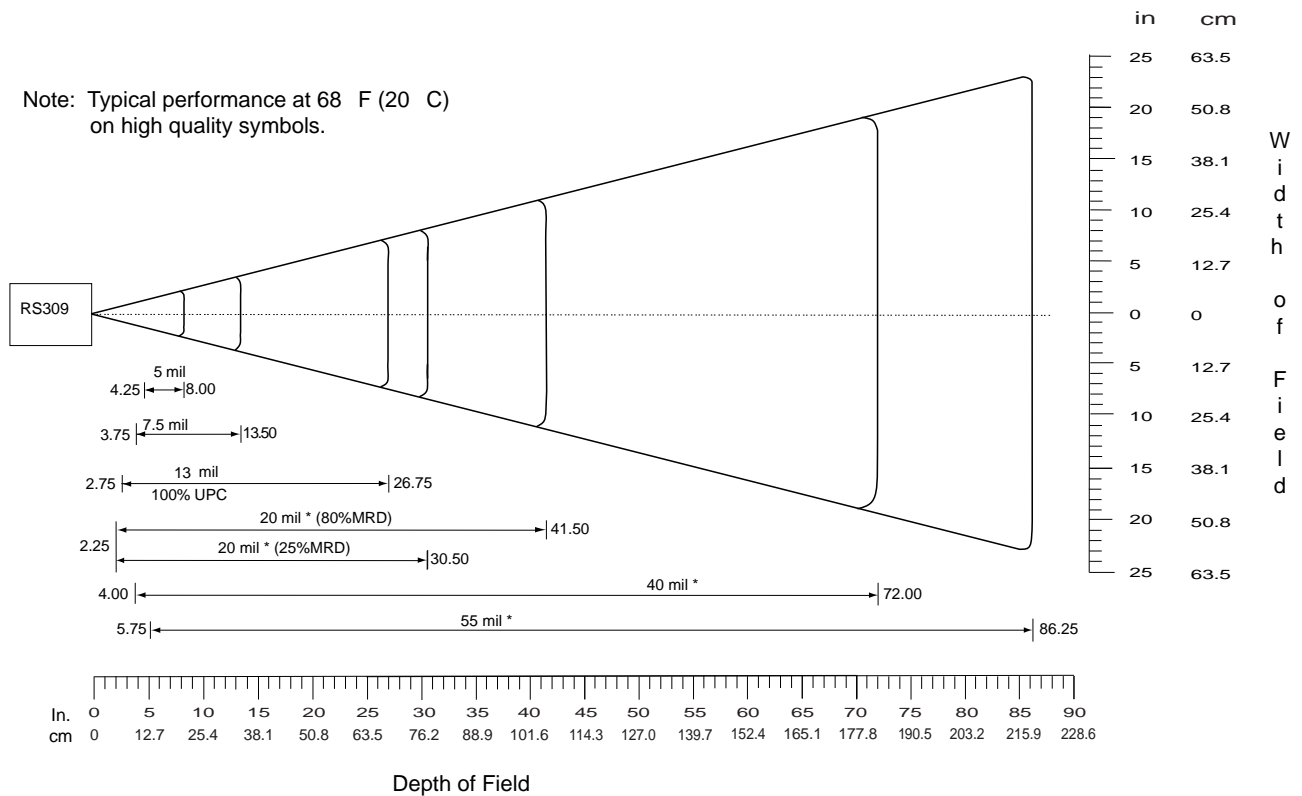

Figure A-3 RS309 30° Decode Zones

Note: Typical performance at 68 F (20 C) on high quality symbols.



*Minimum distance determined by symbol length and scan angle

Figure A-4 RS309 42° Decode Zones

Table A-12 RS309 Decode Distances

Symbol Density/ Bar Code Type/ W-N Ratio	Bar Code Content/ Contrast ^{Note 1}	Typical 30° Working Ranges		Typical 42° Working Ranges	
		Near	Far	Near	Far
5.0 mil Code 39; 2.5:1	ABCDEFGH 80% MRD	4.25 in. 10.79 cm	8.00 in. 20.32 cm	4.50 in 11.43 cm	9.25 in 23.5 cm
7.5 mil Code 39; 2.5:1	ABCDEF 80% MRD	3.75 in. 9.53 cm	13.50 in. 34.29 cm	4.25 in 10.79 cm	14.75 in 37.47 cm
13 mil 100% UPC	012345678905 80% MRD	2.75 in. 6.98 cm	26.75 in. 67.95 cm	3.25 in 8.26 cm	26.00 in 66.04 cm

Notes:

1. CONTRAST measured as Mean Reflective Difference (MRD) at 650 nm.
2. Near ranges on lower densities are largely dependent upon the width of the bar code and the scan angle.
3. Working range specifications: Photographic quality symbols, pitch = 10°, skew = 0°, roll = 0°, ambient light < 150 ft. candles, and temperature = 23°C

Table A-12 RS309 Decode Distances (Continued)

Symbol Density/ Bar Code Type/ W-N Ratio	Bar Code Content/ Contrast ^{Note 1}	Typical 30° Working Ranges		Typical 42° Working Ranges	
		Near	Far	Near	Far
20 mil Code 39; 2.2:1	123 80% MRD	2.25 in. 5.72 cm (Note 2)	41.50 in. 105 cm	2.00 in 5.08 cm (Note 2)	41.50 in 105.41 cm
20 mil Code 39; 2.2:1	123 25% MRD	2.25 in. 5.72 cm (Note 2)	30.50 in. 77.5 cm	2.00 in 5.08 cm (Note 2)	30.50 in 77.5 cm
40 mil Code 39; 2.2:1	AB 80% MRD	4.00 in. 10.16 cm (Note 2)	72.00 in. 182.88 cm	3.25 in 8.26 cm (Note 2)	70.75 in 179.79 cm
55 mil Code 39; 2.2:1	CD 80% MRD	5.75 in. 14.6 cm (Note 2)	86.25 in. 233.05 cm	4.50 in 11.43 cm (Note 2)	86.00 in 228.6 cm

Notes:

1. CONTRAST measured as Mean Reflective Difference (MRD) at 650 nm.
2. Near ranges on lower densities are largely dependent upon the width of the bar code and the scan angle.
3. Working range specifications: Photographic quality symbols, pitch = 10°, skew = 0°, roll = 0°, ambient light < 150 ft. candles, and temperature = 23°C

RS409

Figure A-5 and Figure A-6 show the decode zone for the RS409. The figures are typical values. Table A-13 lists the typical distances for selected bar code densities. The minimum element width (or "symbol density") is the width in mils of the narrowest element (bar or space) in the symbol.

Note: Typical performance at 73.4 F (23 C)
on high quality symbols.

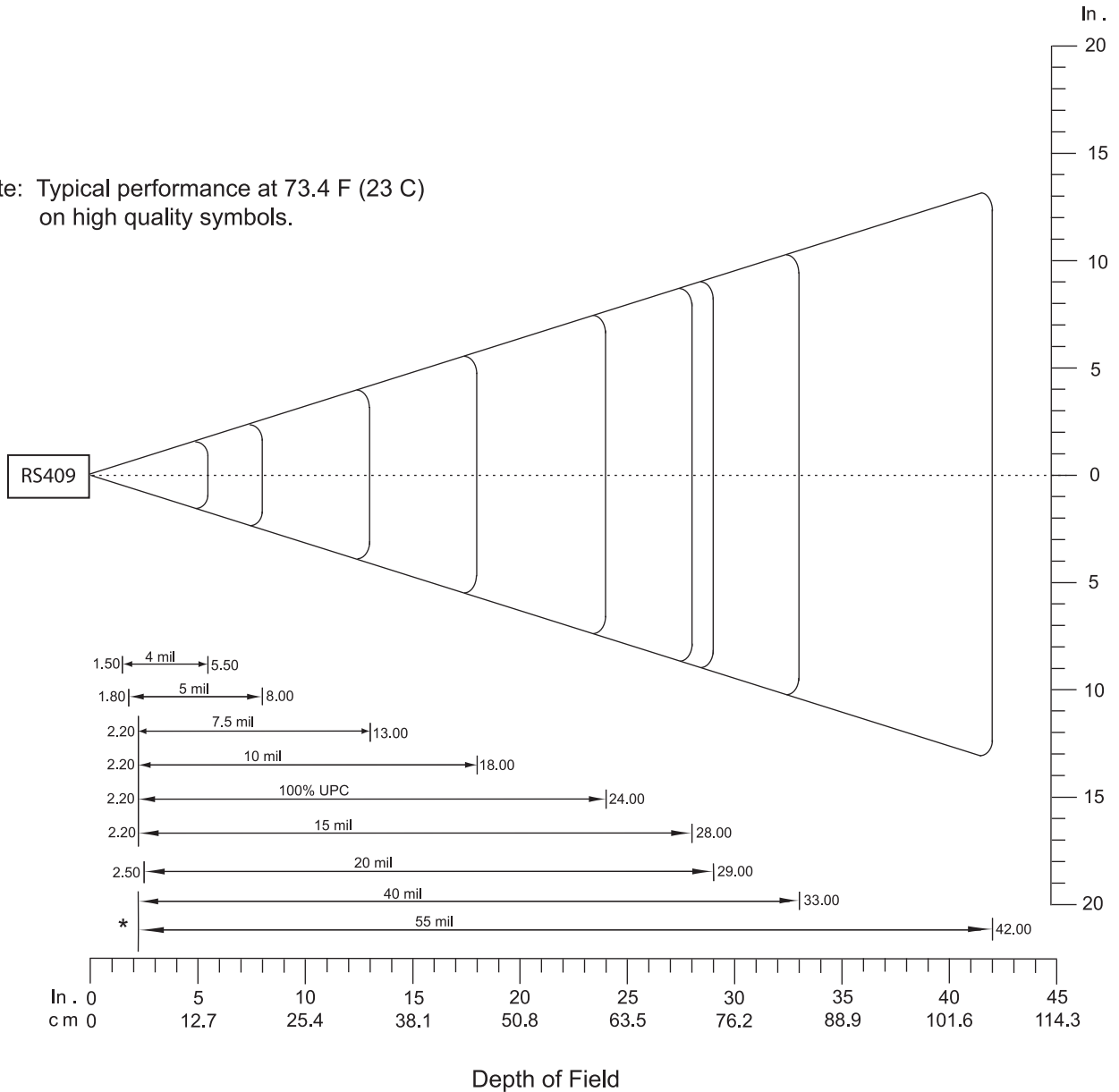

*Minimum distance determined by symbol length and scan angle

Figure A-5 RS409 35° Decode Zone

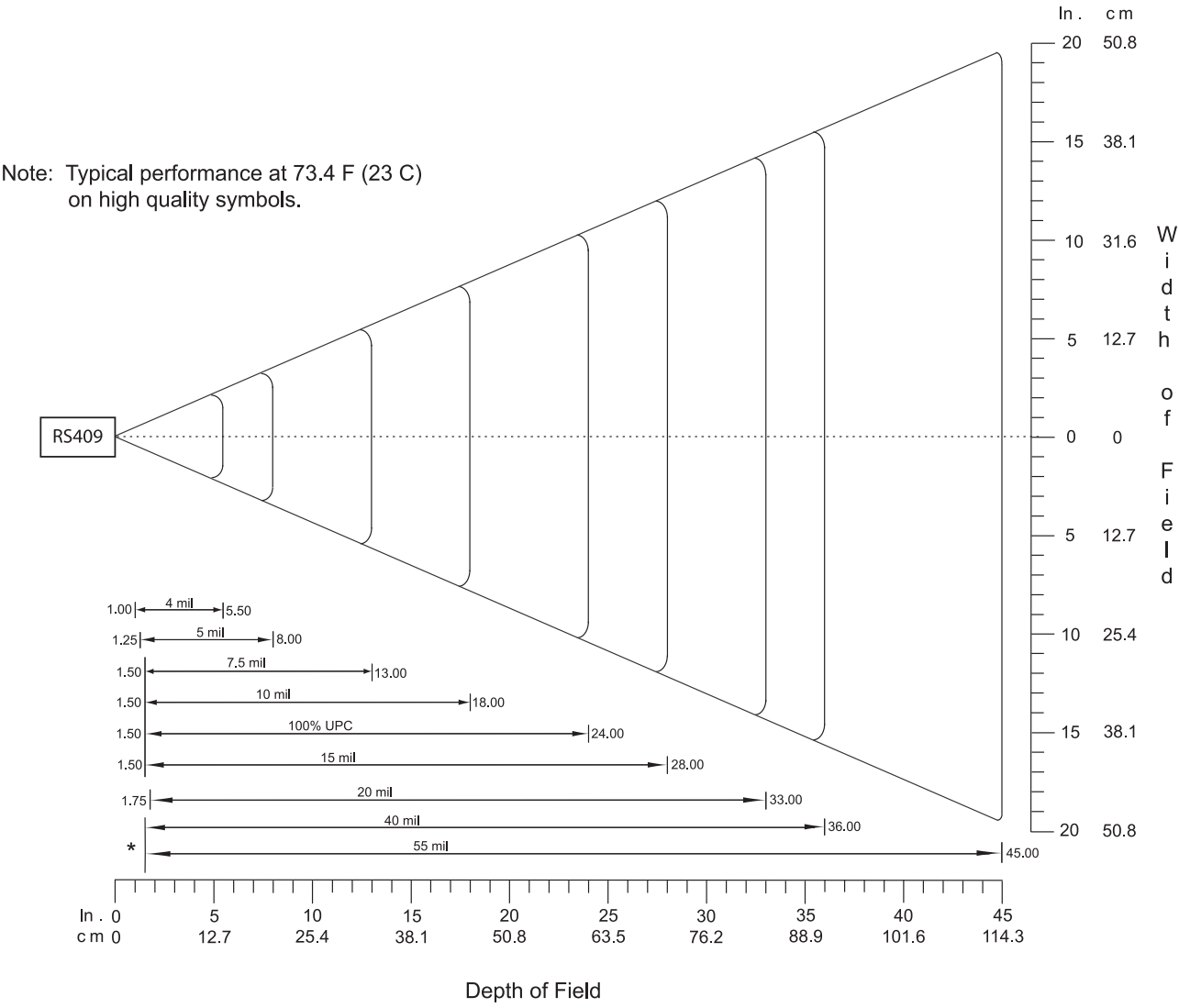

*Minimum distance determined by symbol length and scan angle

Figure A-6 RS409 47° Decode Zone

Table A-13 RS409 Decode Distances

Symbol Density/ Bar Code Type/ W-N Ratio	Bar Code Content/ Contrast ^{Note 1}	35 ° Typical Working Ranges		47 ° Typical Working Ranges	
		Near	Far	Near	Far
4.0 mil Code 39; 2.5:1	ABCDEFGH 80% MRD	1.50 in 3.81 cm	5.50 in 13.97 cm	1.00 in 2.50 cm	5.50 in 13.97 cm
5.0 mil Code 39; 2.5:1	ABCDEFGH 80% MRD	1.80 in 4.57 cm	8.00 in 20.32 cm	1.25 in 3.18 cm	8.00 in 20.32 cm
7.5 mil Code 39; 2.5:1	ABCDEF 80% MRD	2.20 in 5.59 cm	13.00 in 33.02 cm	1.50 in 3.81 cm	13.00 in 33.02 cm
10 mil Code 39; 2.5:1	ABCDE 90% MRD	2.20 in 5.59 cm	18.00 in 45.72 cm	1.50 in 3.81 cm	18.00 in 45.72 cm

Table A-13 RS409 Decode Distances (Continued)

Symbol Density/ Bar Code Type/ W-N Ratio	Bar Code Content/ Contrast ^{Note 1}	35 ° Typical Working Ranges		47 ° Typical Working Ranges	
		Near	Far	Near	Far
13 mil 100% UPC	12345678905 90% MRD	2.20 in 5.59 cm	24.00 in 60.96 cm	1.50 in 3.81 cm	24.00 in 60.96 cm
15 mil Code 39; 2.5:1	ABCD 80% MRD	2.20 in 5.59 cm	28.00 in 71.12 cm	1.50 in 3.81 cm	28.00 in 71.12 cm
20 mil Code 39; 2.2:1	123 80% MRD	2.50 in 6.35 cm	29.00 in 73.66 cm	1.75 in 4.45 cm	33.00 in 83.82 cm
40 mil Code 39; 2.2:1	AB 80% MRD	X	33.00 in 83.82 cm	X	36.00 in 91.44 cm
55 mil Code 39; 2.2:1	CD 80% MRD	X	42.00 in 106.68 cm	X	45.00 in 114.30 cm

Notes:

1. CONTRAST measured as Mean Reflective Difference (MRD) at 650 nm.
2. Near ranges on lower densities (not specified) are largely dependent upon the width of the bar code and the scan angle.
3. Working range specifications at ambient temperature (23°C), Photographic quality symbols. pitch=10°, roll=0°, skew=0°, ambient light < 150 ft-candles.
4. X - Dependent on width of bar code.
5. Distances measured from front edge of chassis.

RS419

Figure A-7 shows the decode zone for the RS419. The figures are typical values. Table A-14 lists the typical distances for selected bar code densities. The minimum element width (or "symbol density") is the width in mils of the narrowest element (bar or space) in the symbol.

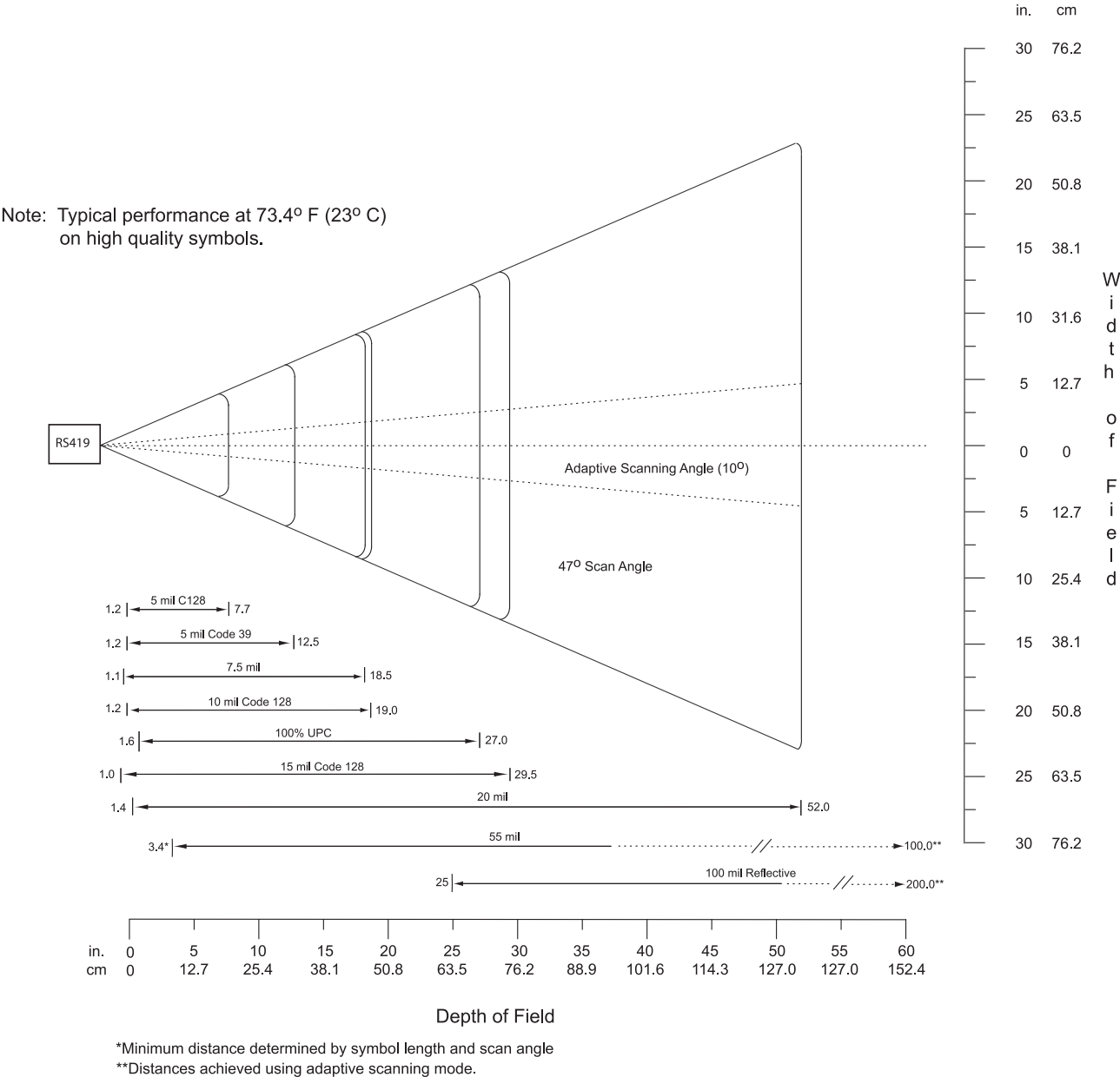

Figure A-7 RS419 Decode Zone

Table A-14 RS419 Decode Distances

Symbol Density/ Bar Code Type/ W-N Ratio	Bar Code Content/ Contrast ^{Note 1}	Typical Working Ranges	
		Near	Far
5.0 mil Code 128	1234 80% MRD	1.2 in 3.05 cm	7.7 in 19.56 cm
5.0 mil Code 39; 2.5:1	ABCDEFGH 80% MRD	1.2 in 3.05 cm	12.5 in 31.75 cm
7.5 mil Code 39; 2.5:1	ABCDEF 80% MRD	1.1 in 2.79 cm	18.5 in 46.99 cm
10 mil Code 128	1234 80% MRD	1.2 in 3.05 cm Note 3	19.0 in 48.26 cm
13 mil 100% UPC	12345678905 80% MRD	1.6 in 4.06 cm	27.0 in 68.58 cm
15 mil Code 128	1234 80% MRD	1.0 in 2.54 cm Note 3	29.5 in 74.93 cm
20 mil Code 39; 2.2:1	123 80% MRD	1.4 in 3.56 cm Note 3	52.0 in 132.08 cm
55 mil Code 39; 2.2:1	CD 80% MRD	3.4 in 8.64 cm Note 3	100.0 in 254.00 cm
100 mil Code 39; 3.0:1 reflective	123456 80% MRD	2 ft 60.96cm Note 3	17 ft 518.16 cm

Notes:

1. Contrast measured as Mean Reflective Difference (MRD) at 650 nm.
2. Working range specifications at ambient temperature (23°C), photographic quality symbols. Pitch=10°, roll=0°, skew=0°, ambient light < 150 ft-candles using Symbol or equivalent decoder.
3. Dependent on width of bar code.
4. Distances measured from front edge of scan engine chassis.

APPENDIX B SOFTWARE SETUP

Bluetooth Configuration Setting

The wearable terminal supports both the Microsoft Bluetooth stack and the StoneStreet One Bluetooth stack. Only one Bluetooth stack can be used at a time. By default, the StoneStreet One Bluetooth stack is enabled. A registry key on the wearable terminal can be modified to disable the StoneStreet One stack and enable the Microsoft stack.

Using a registry editor, navigate to the following:

```
[HKEY_LOCAL_MACHINE\Software\SymbolBluetooth
```

Edit the following key:

```
"SSStack"=dword:1
```

where:

0 = enable Microsoft stack and disable StoneStreet One stack (default)

1 = enable StoneStreet One stack and disable Microsoft stack

After setting the registry key, warm boot the wearable terminal.

GLOSSARY

Numeric

- 802.11.** A group of wireless specifications developed by the Institute of Electrical and Electronics Engineers (IEEE). It specifies an over-the-air interface between a wireless client and a base station or between two wireless clients.
- 802.11a.** Operates in the 5 GHz frequency range (5.125 to 5.85 GHz) with a maximum 54Mbit/sec. signaling rate. The 5 GHz frequency band is not as crowded as the 2.4 GHz frequency because it offers significantly more radio channels than the 802.11b and is used by fewer applications. It has a shorter range than 802.11g and is not compatible with 802.11b.
- 802.11b.** Operates in the 2.4 GHz Industrial, Scientific and Measurement (ISM) band (2.4 to 2.4835 GHz) and provides signaling rates of up to 11Mbit/sec. This is a very commonly used frequency. Microwave ovens, cordless phones, medical and scientific equipment, as well as Bluetooth devices, all work within the 2.4 GHz ISM band.
- 802.11g.** Similar to 802.11b, but this standard supports signaling rates of up to 54Mbit/sec. It also operates in the heavily used 2.4 GHz ISM band but uses a different radio technology to boost overall throughput. Compatible with the 802.11b.

A

- Access Point.** Provides a bridge between Ethernet wired LANs and the wireless network. Access points are the connectivity point between Ethernet wired networks and devices (laptops, hand-held computers, point-of-sale terminals) equipped with a wireless LAN adapter card.
- Ad Hoc Mode.** A wireless network framework in which devices communicate directly with one another without using an access point.
- API.** An interface by means of which one software component communicates with or controls another. Usually used to refer to services provided by one software component to another, usually via software interrupts or function calls
- Application Programming Interface.** See **API**.

ANSI Terminal. A display terminal that follows commands in the ANSI standard terminal language. For example, it uses escape sequences to control the cursor, clear the screen and set colors. Communications programs support the ANSI terminal mode and often default to this terminal emulation for dial-up connections to online services.

Association. The process of determining the viability of the wireless connection and establishing a wireless network's root and designated access points. A wearable terminal associates with its wireless network as soon as it is powered on or moves into range.

Autodiscrimination. The ability of an interface controller to determine the code type of a scanned bar code. After this determination is made, the information content is decoded.

B

Bar Code. A pattern of variable-width bars and spaces which represents numeric or alphanumeric data in machine-readable form. The general format of a bar code symbol consists of a leading margin, start character, data or message character, check character (if any), stop character, and trailing margin. Within this framework, each recognizable symbology uses its own unique format. See **Symbology**.

Bit. Binary digit. One bit is the basic unit of binary information. Generally, eight consecutive bits compose one byte of data. The pattern of 0 and 1 values within the byte determines its meaning.

Bits per Second (bps). Bits transmitted or received.

Bluetooth. A low-cost, short-range radio link between two devices. Bluetooth can replace cables and can be used to create ad hoc networks and provide a standard way to connect devices.

Bit. Binary digit. One bit is the basic unit of binary information. Generally, eight consecutive bits compose one byte of data. The pattern of 0 and 1 values within the byte determines its meaning.

bps. See **Bits Per Second**.

Byte. On an addressable boundary, eight adjacent binary digits (0 and 1) combined in a pattern to represent a specific character or numeric value. Bits are numbered from the right, 0 through 7, with bit 0 the low-order bit. One byte in memory is used to store one ASCII character.

boot or boot-up. The process a computer goes through when it starts. During boot-up, the computer can run self-diagnostic tests and configure hardware and software.

C

CAM. (Continuously Aware Mode) Mode in which the adapter is instructed to continually check for network activity.

CDRH. (Center for Devices and Radiological Health) A federal agency responsible for regulating laser product safety. This agency specifies various laser operation classes based on power output during operation.

CDRH Class 1. This is the lowest power CDRH laser classification. This class is considered intrinsically safe, even if all laser output were directed into the eye's pupil. There are no special operating procedures for this class.

CDRH Class 2. No additional software mechanisms are needed to conform to this limit. Laser operation in this class poses no danger for unintentional direct human exposure.

CHAP. (Challenge Handshake Authentication Protocol) A type of authentication in which the authentication agent (typically a network server) sends the client program a random value that is used only once and an ID value. Both the sender and peer share a predefined secret. The peer concatenates the random value (or nonce), the ID and the secret and calculates a one-way hash using MD5. The hash value is sent to the authenticator, which in turn builds that same string on its side, calculates the MD5 sum itself and compares the result with the value received from the peer. If the values match, the peer is authenticated.

Character. A pattern of bars and spaces which either directly represents data or indicates a control function, such as a number, letter, punctuation mark, or communications control contained in a message.

Character Set. Those characters available for encoding in a particular bar code symbology.

Check Digit. A digit used to verify a correct symbol decode. The scanner inserts the decoded data into an arithmetic formula and checks that the resulting number matches the encoded check digit. Check digits are required for UPC but are optional for other symbologies. Using check digits decreases the chance of substitution errors when a symbol is decoded.

Cold Boot. A cold boot restarts the wearable terminal and erases all user stored records and entries.

COM port. Communication port; ports are identified by number, e.g., COM1, COM2.

Continuous Code. A bar code or symbol in which all spaces within the symbol are parts of characters. There are no intercharacter gaps in a continuous code. The absence of gaps allows for greater information density.

Cradle. A cradle is used for charging the terminal battery and for communicating with a host computer, and provides a storage place for the terminal when not in use.

D

Data Communications Equipment (DCE). A device (such as a modem) which is designed to attach directly to a DTE (Data Terminal Equipment) device.

DCE. See **Data Communications Equipment**.

Decode. To recognize a bar code symbology (e.g., UPC/EAN) and then analyze the content of the specific bar code scanned.

Decode Algorithm. A decoding scheme that converts pulse widths into data representation of the letters or numbers encoded within a bar code symbol.

Decryption. Decryption is the decoding and unscrambling of received encrypted data. Also see, **Encryption** and **Key**.

Depth of Field. The range between minimum and maximum distances at which a scanner can read a symbol with a certain minimum element width.

DTE. See **Data Terminal Equipment**.

E

EAN. (European Article Number) This European/International version of the UPC provides its own coding format and symbology standards. Element dimensions are specified metrically. EAN is used primarily in retail.

EAP. (Extensible Authentication Protocol) A general authentication protocol used to control network access. Many specific authentication methods work within this framework.

EAP-PEAP. (Extensible Authentication Protocol-Protected Extensible Authentication Protocol) A mutual authentication method that uses a combination of digital certificates and another system, such as passwords.

EAP-TLS. (Extensible Authentication Protocol-Transport Layer Security) A mutual authentication method that uses digital certificates.

Encoded Area. Total linear dimension occupied by all characters of a code pattern, including start/stop characters and data.

Encryption. Encoding data to prevent it from being read by unauthorized people.

ENQ (RS-232). ENQ software handshaking is also supported for the data sent to the host.

EMDK. Enterprise Mobility Developer's Kit.

Ethernet . An IEEE standard network protocol that specifies how data is placed on and retrieved from a common transmission medium.

ESD. Electro-Static Discharge

F

Flash Disk. An additional megabyte of non-volatile memory for storing application and configuration files.

Flash Memory. Flash memory is nonvolatile, semi-permanent storage that can be electronically erased in the circuit and reprogrammed.

File Transfer Protocol (FTP). A TCP/IP application protocol governing file transfer via network or telephone lines. See **TCP/IP**.

H

Hard Reset. See **Cold Boot**.

Hz. Hertz; A unit of frequency equal to one cycle per second.

Host Computer. A computer that serves other terminals in a network, providing such services as computation, database access, supervisory programs and network control.

I

IEC. International Electrotechnical Commission. This international agency regulates laser safety by specifying various laser operation classes based on power output during operation.

IEC (825) Class 1. This is the lowest power IEC laser classification. Conformity is ensured through a software restriction of 120 seconds of laser operation within any 1000 second window and an automatic laser shutdown if the scanner's oscillating mirror fails.

IEEE Address. See **MAC Address**.

Internet Protocol Address. See **IP**.

I/O Ports. interface The connection between two devices, defined by common physical characteristics, signal characteristics, and signal meanings. Types of interfaces include RS-232 and PCMCIA.

Input/Output Ports. I/O ports are primarily dedicated to passing information into or out of the terminal's memory. Series 9000 wearable terminals include Serial and USB ports.

IP. (Internet Protocol) The IP part of the TCP/IP communications protocol. IP implements the network layer (layer 3) of the protocol, which contains a network address and is used to route a message to a different network or subnetwork. IP accepts "packets" from the layer 4 transport protocol (TCP or UDP), adds its own header to it and delivers a "datagram" to the layer 2 data link protocol. It may also break the packet into fragments to support the maximum transmission unit (MTU) of the network.

IP Address. (Internet Protocol address) The address of a computer attached to an IP network. Every client and server station must have a unique IP address. A 32-bit address used by a computer on a IP network. Client workstations have either a permanent address or one that is dynamically assigned to them each session. IP addresses are written as four sets of numbers separated by periods; for example, 204.171.64.2.

IPX/SPX. Internet Package Exchange/Sequential Packet Exchange. A communications protocol for Novell. IPX is Novell's Layer 3 protocol, similar to XNS and IP, and used in NetWare networks. SPX is Novell's version of the Xerox SPP protocol.

IS-95. Interim Standard 95. The EIA/TIA standard that governs the operation of CDMA cellular service. Versions include IS-95A and IS-95B. See CDMA.

K

Key. A key is the specific code used by the algorithm to encrypt or decrypt the data. Also see, **Encryption** and **Decrypting**.

L

laser scanner. A type of bar code reader that uses a beam of laser light.

LASER. (Light Amplification by Stimulated Emission of Radiation) The laser is an intense light source. Light from a laser is all the same frequency, unlike the output of an incandescent bulb. Laser light is typically coherent and has a high energy density.

LCD. See **Liquid Crystal Display.**

LEAP. (Lightweight Extensible Authentication Protocol) A mutual authentication method that uses a username and password system.

LED Indicator. A semiconductor diode (LED - Light Emitting Diode) used as an indicator, often in digital displays. The semiconductor uses applied voltage to produce light of a certain frequency determined by the semiconductor's particular chemical composition.

Liquid Crystal Display (LCD). A display that uses liquid crystal sealed between two glass plates. The crystals are excited by precise electrical charges, causing them to reflect light outside according to their bias. They use little electricity and react relatively quickly. They require external light to reflect their information to the user.

M

MC. Mobile computer.

MDN. (Mobile Directory Number) The directory listing telephone number that is dialed (generally using POTS) to reach a mobile unit. The MDN is usually associated with a MIN in a cellular telephone -- in the US and Canada, the MDN and MIN are the same value for voice cellular users. International roaming considerations often result in the MDN being different from the MIN.

MIL. 1 mil = 1 thousandth of an inch.

MIN. (Mobile Identification Number) The unique account number associated with a cellular device. It is broadcast by the cellular device when accessing the cellular system.

MS CHAP. (Microsoft Challenge Handshake Authentication Protocol) is the Microsoft version of CHAP and is an extension to RFC 1994. Like the standard version of CHAP, MS-CHAP is used for PPP authentication; in this case, authentication occurs between a PC using Microsoft Windows NT or Microsoft Windows 95 and a Cisco router or access server acting as a network access server (NAS).

N

Nominal. The exact (or ideal) intended value for a specified parameter. Tolerances are specified as positive and negative deviations from this value.

Nominal Size. Standard size for a bar code symbol. Most UPC/EAN codes are used over a range of magnifications (e.g., from 0.80 to 2.00 of nominal).

NVM. Non-Volatile Memory.

O

ODI. See **Open Data-Link Interface**.

Open Data-Link Interface (ODI). Novell's driver specification for an interface between network hardware and higher-level protocols. It supports multiple protocols on a single NIC (Network Interface Controller). It is capable of understanding and translating any network information or request sent by any other ODI-compatible protocol into something a NetWare client can understand and process.

Open System Authentication. Open System authentication is a null authentication algorithm.

P

PAN . Personal area network. Using Bluetooth wireless technology, PANs enable devices to communicate wirelessly. Generally, a wireless PAN consists of a dynamic group of less than 255 devices that communicate within about a 33-foot range. Only devices within this limited area typically participate in the network.

Parameter. A variable that can have different values assigned to it.

PING. (Packet Internet Groper) An Internet utility used to determine whether a particular IP address is online. It is used to test and debug a network by sending out a packet and waiting for a response.

Programming Mode. The state in which a scanner is configured for parameter values. See **Scanning Mode**.

Q

Quiet Zone. A clear space, containing no dark marks, which precedes the start character of a bar code symbol and follows the stop character.

R

RAM. Random Access Memory. Data in RAM can be accessed in random order, and quickly written and read.

RF. Radio Frequency.

ROM. Read-Only Memory. Data stored in ROM cannot be changed or removed.

Router. A device that connects networks and supports the required protocols for packet filtering. Routers are typically used to extend the range of cabling and to organize the topology of a network into subnets. See **Subnet**.

RS-232. An Electronic Industries Association (EIA) standard that defines the connector, connector pins, and signals used to transfer data serially from one device to another.

S

Scanner. An electronic device used to scan bar code symbols and produce a digitized pattern that corresponds to the bars and spaces of the symbol. Its three main components are:

1. Light source (laser or photoelectric cell) - illuminates a bar code.
2. Photodetector - registers the difference in reflected light (more light reflected from spaces).
3. Signal conditioning circuit - transforms optical detector output into a digitized bar pattern.

Scanning Mode. The scanner is energized, programmed and ready to read a bar code.

Scanning Sequence. A method of programming or configuring parameters for a bar code reading system by scanning bar code menus.

SDK. Software Development Kit

Secure Sockets Layer (SSL). SSL is a commonly-used protocol for managing the security of a message transmission on the Internet. SSL uses a program layer located between the Internet's Hypertext Transfer Protocol (HTTP) and Transport Control Protocol (TCP) layers. SSL is included as part of both the Microsoft and Netscape browsers and most Web server products. Developed by Netscape, SSL also gained the support of Microsoft and other Internet client/server developers as well and became the de facto standard until evolving into Transport Layer Security. The "sockets" part of the term refers to the sockets method of passing data back and forth between a client and a server program in a network or between program layers in the same computer. SSL uses the public-and-private key encryption system from RSA, which also includes the use of a digital certificate.

Shared Key. Shared Key authentication is an algorithm where both the AP and the MU share an authentication key.

Soft Reset. See **Warm Boot.**

Specular Reflection. The mirror-like direct reflection of light from a surface, which can cause difficulty decoding a bar code.

Subnet. A subset of nodes on a network that are serviced by the same router. See **Router.**

Subnet Mask. A 32-bit number used to separate the network and host sections of an IP address. A custom subnet mask subdivides an IP network into smaller subsections. The mask is a binary pattern that is matched up with the IP address to turn part of the host ID address field into a field for subnets. Default is often 255.255.255.0.

Substrate. A foundation material on which a substance or image is placed.

Symbol. A scannable unit that encodes data within the conventions of a certain symbology, usually including start/stop characters, quiet zones, data characters and check characters.

Symbology. The structural rules and conventions for representing data within a particular bar code type (e.g. UPC/EAN, Code 39, PDF417, etc.).

T

TCP/IP. (Transmission Control Protocol/Internet Protocol) A communications protocol used to internetwork dissimilar systems. This standard is the protocol of the Internet and has become the global standard for communications. TCP provides transport functions, which ensures that the total amount of bytes sent is received correctly at the other end. UDP is an alternate transport that does not guarantee delivery. It is widely used for real-time voice and video

transmissions where erroneous packets are not retransmitted. IP provides the routing mechanism. TCP/IP is a routable protocol, which means that all messages contain not only the address of the destination station, but the address of a destination network. This allows TCP/IP messages to be sent to multiple networks within an organization or around the world, hence its use in the worldwide Internet. Every client and server in a TCP/IP network requires an IP address, which is either permanently assigned or dynamically assigned at startup.

Telnet. A terminal emulation protocol commonly used on the Internet and TCP/IP-based networks. It allows a user at a terminal or computer to log onto a remote device and run a program.

Terminal Emulation. A “terminal emulation” emulates a character-based mainframe session on a remote non-mainframe terminal, including all display features, commands and function keys. The WT41N0 Series supports Terminal Emulations in 3270, 5250 and VT220.

TFTP. (Trivial File Transfer Protocol) A version of the TCP/IP FTP (File Transfer Protocol) protocol that has no directory or password capability. It is the protocol used for upgrading firmware, downloading software and remote booting of diskless devices.

TKIP. (Temporal Key Integrity Protocol) A wireless encryption protocol that periodically changes the encryption key, making it harder to decode.

Tolerance. Allowable deviation from the nominal bar or space width.

Transmission Control Protocol/Internet Protocol. See **TCP/IP**.

TLS. (Transport Layer Security) TLS is a protocol that ensures privacy between communicating applications and their users on the Internet. When a server and client communicate, TLS ensures that no third party may eavesdrop or tamper with any message. TLS is the successor to the Secure Sockets Layer (SSL).

Trivial File Transfer Protocol. See **TFTP**.

TSR. See **Terminate and Stay Resident**.

U

UDP. (User Datagram Protocol) A protocol within the IP protocol suite that is used in place of TCP when a reliable delivery is not required. For example, UDP is used for real-time audio and video traffic where lost packets are simply ignored, because there is no time to retransmit. If UDP is used and a reliable delivery is required, packet sequence checking and error notification must be written into the applications.

U

Visible Laser Diode (VLD). A solid state device which produces visible laser light.

W

Warm Boot. A warm boot restarts the wearable terminal by closing all running programs. All data that is not saved to flash memory is lost.

WAP. (Wireless Application Protocol) A set of specifications, developed by the WAP Forum, that lets developers using Wireless Markup Language build networked applications designed for handheld wireless devices. WAP was designed to work within the constraints of these devices: a limited memory and CPU size, small, monochrome screens, low bandwidth and erratic connections.

Wearable Terminal. In this text, wearable terminal refers to the WT41N0 wireless portable computer. It can be set up to run as a stand-alone device, or it can be set up to communicate with a network, using wireless radio technology.

WEP. Wired-Equivalent Privacy protocol was specified in the IEEE 802.11 standard to provide a WLAN with a minimal level of security and privacy comparable to a typical wired LAN, using data encryption.

WPA. Wi-Fi Protected Access is a data encryption specification for 802.11 wireless networks that replaces the weaker WEP. It improves on WEP by using dynamic keys, Extensible Authentication Protocol to secure network access, and an encryption method called Temporal Key Integrity Protocol (TKIP) to secure data transmissions.

WPA2. Wi-Fi Protected Access 2 is an enhanced version of WPA. It uses Advanced Encryption Standard instead of TKIP.

WLAN. Wireless local-area networks use radio waves instead of a cable to connect a user device, such as a wearable terminal, to a LAN. They provide Ethernet connections over the air and operate under the 802.11 family of specifications developed by the IEEE.

INDEX

A

- accessories
 - four slot Ethernet cradle 2-6
 - four slot Ethernet/USB cradle 2-1
 - four slot spare battery charger 2-1
 - serial/USB cradle 2-1
 - single slot serial/USB cradle 2-3
 - LED indicators 2-4, 2-14
 - spare battery charger 2-13
 - power connection 2-13
- ActiveSync 3-2
- Adaptive Frequency Hopping 6-1
- adding programs
 - using BootLoader 7-9, 7-11
- AFH 6-1
- application deployment 7-1

B

- backup battery
 - charging 1-4
- battery
 - backup charging 1-4
 - charging 1-4
 - temperature range A-9, A-10
 - check status 1-7
 - installing 1-3
 - removing 1-5
- battery charging temperature A-2
- battery management 1-8
- bluetooth
 - adaptive frequency hopping 6-1
 - bonding 6-18
 - deleting bonded device 6-21
 - discovering devices 6-9, 6-31
 - turning off 6-7, 6-30

- turning on 6-7, 6-30
- Bluetooth printing 6-33
- Bluetooth security 6-2
- bonding, bluetooth 6-18
- boot
 - cold 1-6, 1-8, 6-4
 - warm 1-8, 6-4
- BootLoader 7-4
 - error messages 7-13
- bullets xiv

C

- CAB files
 - deployment via image update 7-8
- changing the power settings 1-9
- charging
 - spare batteries 1-5
 - temperature range A-9, A-10
- charging batteries 1-4
- charging spare batteries 1-5
- cleaning 9-1
- cold boot 1-6, 1-8, 6-4
- configuration xii
- configurations xii
- conventions
 - notationalxiii
- CPU A-2
- cradles
 - Ethernet drivers 2-10
 - four slot Ethernet 2-6
 - four slot Ethernet/USB 2-1
 - serial/USB 2-1
 - single slot 2-3
 - LED indicators 2-4, 2-14
 - spare battery charger 2-13
 - power connection 2-13

creating a splash screen 7-15

D

data capture xii
 decode distances A-20
 SE950-I100R A-17
 decode zone A-16, A-17, A-19
 SE1224HP-I000A A-13
 deleting bluetooth bond 6-21
 deployment 7-1
 dimensions A-1, A-3, A-4, A-5, A-6, A-8
 display xii, A-1
 display backlight
 saving power 1-9
 drop specification A-2, A-4, A-5, A-6, A-7, A-9

E

EMDK 7-1, 7-2
 EMDK for eVC4 xiv
 Enterprise Mobility Developer Kit for eVC4 xiv
 error messages 7-13

F

file update 7-5
 flash file system 7-3
 downloading partitions 7-4
 non-FFS partitions 7-4
 BootLoader 7-4
 splash screen 7-4
 partitions 7-3
 copyfile 7-4
 regmerge 7-3
 flash storage 7-2
 four slot Ethernet cradle 2-6, 2-17
 drivers 2-10
 four slot Ethernet/USB 2-1
 four slot spare battery charger 2-1, 2-19

G

getting started 1-3

H

hard reset 1-6, 1-8, 6-4
 humidity A-2, A-3, A-4, A-5, A-7, A-8

I

image update
 deploying CAB files 7-8

information, service xv
 installation

 development tools 7-2
 installing main battery 1-3
 Installing Window Mobile Device Center 3-1

K

keyboard A-1
 keypad backlight
 saving power 1-9
 keypads xii

L

lithium-ion battery 1-1

M

main battery
 charging 1-3, 1-4
 temperature range A-9, A-10
 installing 1-3
 maintenance 9-1
 memory xii, A-2

O

operating environment, wearable terminal A-1
 operating system xii, A-2
 operating temperature A-2, A-3, A-4, A-5, A-7, A-8

P

partition update 7-5
 partitions
 downloading 7-4
 FFS 7-3
 non-FFS 7-4
 BootLoader 7-4
 splash screen 7-4
 parts of the wearable terminal 1-1, 1-2, 1-3
 pin-outs
 wearable terminal A-11
 Platform SDK 7-1
 power settings 1-9
 power supply 2-16
 printing
 Bluetooth 6-33
 programs
 adding using BootLoader 7-9, 7-11
 flash file system 7-3
 provisioning 7-15
 PSDK 7-1

R

radios xii
 RegMerge.dll 7-3
 related documents xiv
 related software xiv
 removing main battery 1-5
 reset
 hard 1-6, 1-8, 6-4
 soft 1-8, 6-4
 resetting 1-8
 resume 6-4

S

serial/USB cradle 2-1
 service information xv
 setting up a partnership
 partnership 3-4
 single slot serial/USB cradle 2-3
 LED indicators 2-4, 2-14
 soft reset 1-8, 6-4
 software installation 7-15
 BootLoader 7-9, 7-11
 spare batteries
 charging 1-5
 spare battery
 charging 1-5
 spare battery charger 2-13
 power connection 2-13
 splash screen 7-4
 creating 7-15
 starting the wearable terminal 1-3, 1-6
 storage temperature A-2, A-3, A-4, A-5, A-7, A-8
 suspend 1-5, 6-4
 Syncing
 Installing ActiveSync 3-1
 Windows Mobile Device Center 3-3

T

technical specifications, wearable terminal A-1
 temperature
 battery charging A-9, A-10
 troubleshooting 9-6
 four slot spare battery charger 9-10
 turn the radios off
 saving power 1-10

U

unpacking 1-1

W

wall mounting bracket 2-15
 mounting multiple brackets 2-21
 wiring 2-19
 warm boot 1-8, 6-4
 wearable terminal
 starting 1-6
 weight A-1, A-3, A-4, A-5, A-6, A-8
 Windows Mobile Device Center 3-3
 WLAN 802.11a/b/g xii
 WPAN Bluetooth xii



Zebra Technology Corporation
Lincolnshire, IL USA
<http://www.zebra.com>

Zebra and the stylized Zebra head are trademarks of ZIH Corp., registered in many jurisdictions worldwide. All other trademarks are the property of their respective owners.

© 2016 Symbol Technologies LLC, a subsidiary of Zebra Technologies Corporation. All rights reserved.

